



Installation, Operating & Maintenance Sheet



SolConeX Receptacle & Plug 125 A

> 8581/41 & 8581/22



1 Contents

1	Contents	2
2	General Information	2
3	Application	3
4	Safety Instructions	3
5	Conformity to Standards	4
6	Technical Data	4
7	Transport and Storage	4
8	Receptacle Installation	4
9	Receptacle Wiring	5
10	Plug Wiring	6
11	Commissioning	7
12	Maintenance	7
13	Disposal	8

2 General Information

2.1 Manufacturer

R. STAHL Schaltgeräte GmbH
 Am Bahnhof 30
 74638 Waldenburg
 Germany
 Tel.: +49 7942 943-0
 Fax: +49 7942 943-4333
 Internet: www.stahl-ex.com

Manufacturer North American Contacts

USA

R. STAHL, INC.
 13259 N. Promenade Blvd.
 Stafford, TX 77477
 Tel.: 800 782-4357
 Fax: 281 313-9302
 Internet: www.rstahl.com

Canada

R. STAHL, LTD.
 7003 - 56 Avenue
 Edmonton, AB T6B 3L2
 Tel.: 877 416-4302
 Fax: 780 469-5525
 Internet: www.rstahl.com

2.2 Information regarding this Installation, Operation and Maintenance Sheet

ID-No.: 209880 / 8581616300
 Publication Code: 2014-10-10-IO00-III-en-03
 Subject to alterations.

2.3 Disclaimer

The nature of these instructions is only informative and does not cover all of the details, variations or combinations in which this equipment may be used, stored, delivered, installed, safely operated and maintained.

Since conditions of use of the product are outside of the care, custody and control of the manufacturer, the purchaser should determine the suitability of the product for his intended use, and assumes all risk and liability whatsoever in connection therewith.

Technical information and illustrations are not binding and subject to change without notice.

3 Application

The receptacle 8581/41 and the plug 8581/22 are explosion protected equipment, certified for use in hazardous (classified) locations.

4 Safety Instructions

The receptacles and plugs must be used only for their intended purpose. Incorrect usage invalidates our warranty provision.

WARNING

Installation and maintenance of this product should only be performed by skilled and experienced personnel in accordance with the National Electrical Code (NFPA 70 - NEC) or the Canadian Electrical Code (CEC), respectively, and applicable local code regulations.

CAUTION:

- ▶ Disconnect power supply before installing or servicing these receptacles and/or plugs.
- ▶ Modifications to this product are not permitted.
- ▶ Operate only undamaged and clean devices with observations of the operating parameters in section 6.
- ▶ For a Class I Zone 1 conduit installation, conduit seals are required, refer to NFPA 70 (NEC) 505.16 (B) (1) or CEC C22.1. For any cable or other conduit installation, NO seals are required.
- ▶ Use only approved wiring methods for the location with the associated conduit/cable fittings.
- ▶ The receptacle is suitable for use on a circuit capable of delivering not more than 10,000 rms symmetrical amperes, 600 V maximum, when protected by properly sized Class J fuses, 200 amperes maximum. Supply wires shall be rated for + 75 °C.

5 Conformity to Standards

The 8581/41 Series of receptacles and the 8581/22 Series of plugs have multiple certifications printed on the nameplate.

6 Technical Data

Please refer to the technical data on the nameplates.

Explosion protection	
NEC	Class I, Zone 1&2, AEx d e IIC T5 Gb Class I, Div. 2, Groups ABCD T5 Class II, Div. 1 & 2, Groups EFG Class III Ta = -30 °C (-22 °F) ... +40 °C (+104 °F)
CEC	Class I, Zone 1&2, Ex d e IIC T5 Gb Class I, Div. 2 per CEC J18-150 Class II, Div. 1, Groups G Ta = -30 °C (-22 °F) ... +40 °C (+104 °F)
IECEX	Ex d e IIC T6 (Ta = - 30 ... + 40 °C) Ex d e IIC T5 (Ta = - 30 ... + 45 °C)
ATEX	⊕ II 2 G Ex d e [ib] IIC T6, T5, T4 ⊕ II 2 D Ex tD A21 IP66 T60 °C...T105 °C

Certificates
NEC / CEC

IECEX
ATEX

Ambient temperature



FM File No. 0R6A2.AX

IECEX PTB 06.0034

PTB 01 ATEX 1161

see explosion protection data -45 °C on request (internal lubrication using silicone grease)

Assignment of temperature class / ambient temperature / rated operational voltage / rated connection cross-section

Valid for the following versions: 209879_V03

Temperature class		Rated operational current	Rated connection cross-section	
T6	T5		Socket	Plug
	≤ + 45 °C	125 A	70 mm ²	50 mm ²
≤ + 40 °C	≤ + 55 °C	110 A		
≤ + 45 °C	≤ + 60 °C	100 A		
	≤ + 40 °C	125 A	50 to 70 mm ²	35 mm ² Use only heat-resistant cables ≥ 85 °C, e.g., Type NSSHÖU!
	≤ + 45 °C	115 A		
≤ + 40 °C	≤ + 55 °C	100 A	50 to 70 mm ²	35 mm ²

7 Transport and Storage

- Transport and storage are only permitted in the original packing.

8 Receptacle Installation

8.1 Enclosure mounting

Securely mount the receptacle in a vertical position as illustrated, using three 3/8" (10 mm) screws and suitable washers. Mounting dimensions are marked on the back of the receptacle housing.

8.2 Conduit/Cable installation

For conduit installation, connect 2" NPT conduit to the hub and avoid misalignment. For cable installation, connect a listed 2" cable fitting to the hub. Conduit/cable fitting should not be tightened more than 100 ft-lbs (136 Nm) of torque.

8.3 Auxiliary contact

When using the 6 A rated early break and late make auxiliary contact for an electrical interlock or other control signal, connect 12 AWG copper wire to terminals 13 and 14. Torque the terminal screws to 3.54 in-lbs (0.4 Nm).

8.4 Function label

Remove the plastic function label (taped inside the cover), mark as required, remove backing strip and apply to the recessed area above the switch. Close the cover and tighten the cover screws.

8.5 Receptacle HP Rating

3-Phase	Horsepower
600 V AC	125
480 V AC	100
250 V AC	40

9 Receptacle Wiring

- ▶ Open the terminal cover and connect + 75 °C or greater copper supply wires.
- ▶ The supply side of the terminal block accepts up to two wires per terminal. The wire size should be based on the ampere configuration.

Configuration	AWG
≤ 125 A	3/0
≤ 115 A	2/0

- ▶ Allow proper length for bending and cut the conductors to length.
- ▶ Strip the conductor insulation 1" (25 mm) from the end.
- ▶ Insert the conductors into the appropriate terminals which are marked to correspond with the markings on the plug.
- ▶ Torque all terminal screws to 221 - 265 in-lbs (25 - 30 Nm); including all unused terminals.

10 Plug Wiring

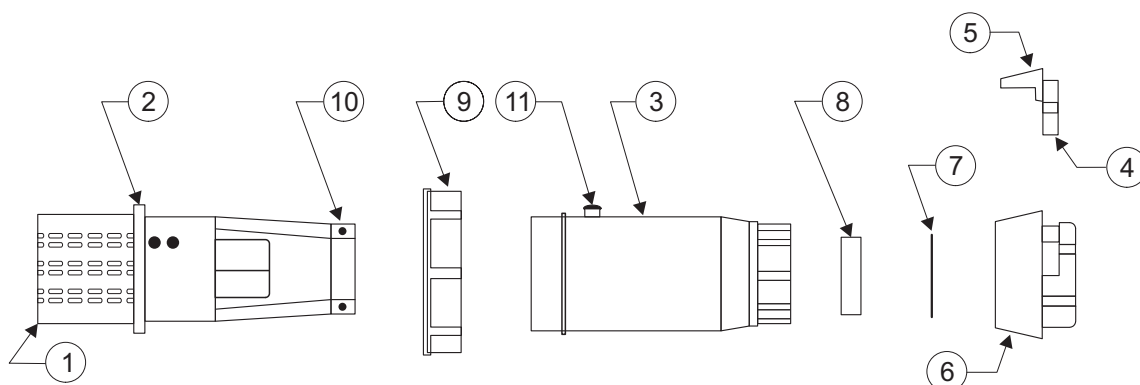



Figure 1.

14966E00

10.1 Cord type

Select a flexible cord with copper conductors of the appropriate insulation, ampacity and + 90 °C temperature rating. For installations in the U.S., refer to the National Electrical Code Articles 400-4, 400-5A, 400-5B, 501-11, 502-12 and 503-10. For installation in Canada, refer to CEC Sections 4 and 18.

	<p>Note: Maximum range for plug terminals is 6-1 AWG. Tighten terminal screws to 54 in-lbs (6 Nm) torque.</p>
---	---

10.2 Cord preparation

Cut the cord cleanly - Do not strip away cord jacket or conductor insulation at this time.

10.3 Opening the plug

Referring to Figure 1 above, loosen the three screws ① and pull the plug body ② out of the shell ③. Loosen the screw ④ on the locking clamp ⑤, insert the screwdriver in the locking clamp slot, lift the locking clamp out of the pressure ring ⑥ and unscrew the pressure ring.

10.4 Insert the cord

- ▶ Slide the pressure ring ⑥ and the washer ⑦ over the cord.
- ▶ Install the cord grommet. The grommet ⑧ is an universal onion ring style which accommodates several cord diameters by removing (cutting out) the inner undersized diameters. The grommet should fit snugly on the cord. The grommet may require lubrication in order to slide over the cord. Use talcum powder or an equivalent material rated for use on electrical products. Slide the grommet over the cord with the cuts toward the shell ③.

 Note: If the grommet slides freely over the cord, there will be insufficient sealing for Class II and Class III Hazardous Locations.

- ▶ Slide the shell ③ and collar ⑨ over the cord.

10.5 Cord preparation

Dress the cord by removing the outer jacket and fillers for a length of 4-1/8" (105 mm) and strip the insulation off of the conductors 1-7/16" (36 mm) from the end.

10.6 Connection to terminals

Open the strain relief clamp screws ⑩ and flip the clamp to the side. Attach the leads to the appropriate terminals. Terminal markings correspond to receptacle terminal markings.

 **WARNING**

The Equipment Ground (green wire) is to be connected to the terminal marked with the Ground (Earth) symbol .

10.7 Strain relief

Flip back the strain relief clamp ⑩, remove clamp's plastic inserts, if necessary, to fit the outer diameter of the cord. Make sure that the remaining plastic inserts have their ridges pointing toward the plug before tightening.

10.8 Plug assembly

- ▶ Slide the locking collar ⑨ into the shell ③ and insert the plug body ② into the shell. To align the plug body ② with the shell ③, the keyway on the inside of the shell must mate with the rib in the plug body.
- ▶ Tighten the three screws ①.
- ▶ Slide the grommet ⑧ and the gland washer ⑦ forward until they shoulder against the shell ③ and tighten the pressure ring ⑥ until a good grommet compression is achieved.
- ▶ Reinstall the locking clamp ⑤ and tighten the screw ④.

10.9 Optional dust cap

The optional dust cap (P/N 85 818 01 14 0) must be used for Class II Hazardous Locations. Attach the dust cap to the post ⑪.

⚠ WARNING

Observe the labels on the receptacle and plug with regard to the use of receptacle covers and plug dust caps.

11 Commissioning

Before commissioning into service

- ▶ Make sure that the device is not damaged.
- ▶ Make sure that the device is installed correctly.
- ▶ Remove any foreign objects from the device.
- ▶ Check the tightening torques.

12 Maintenance

These receptacles require no maintenance other than a periodic inspection for damage and proper operation. Any damaged equipment should be replaced promptly to ensure the electrical safety and explosion protection of the system.



Separate plugs and receptacles at regular intervals to prevent contact corrosion.

13 Disposal

The national and local waste disposal regulations have to be observed.

