



## CPU & Power Modul für Zone 1 / Div. 1

Reihe 9440/22, 9490



## Inhaltsverzeichnis

1	Allgemeine Angaben .....	3
1.1	Hersteller .....	3
1.2	Angaben zur Betriebsanleitung .....	3
1.3	Weitere Dokumente .....	3
1.4	Konformität zu Normen und Bestimmungen .....	3
2	Erläuterung der Symbole .....	4
2.1	Symbole in der Betriebsanleitung .....	4
2.2	Warnhinweise .....	4
2.3	Symbole am Gerät .....	5
3	Sicherheitshinweise .....	5
3.1	Aufbewahrung der Betriebsanleitung .....	5
3.2	Qualifikation des Personals .....	5
3.3	Sichere Verwendung .....	6
3.4	Umbauten und Änderungen .....	7
4	Funktion und Geräteaufbau .....	7
4.1	Funktion .....	8
4.2	Geräteaufbau .....	8
5	Technische Daten .....	9
6	Projektierung .....	14
6.1	Anschlussbelegung Hilfsenergieanschluss .....	15
6.2	Anschlussbelegung Sub-D-Buchsen X1, X2, X3 .....	15
7	Transport und Lagerung .....	15
8	Montage und Installation .....	16
8.1	Maßangaben / Befestigungsmaße .....	17
8.2	Montage / Demontage, Gebrauchslage .....	18
8.3	Installation .....	20
9	Parametrierung und Inbetriebnahme .....	21
9.1	Parametrierungen .....	21
10	Betrieb .....	27
10.1	Betrieb .....	27
10.2	Anzeigen .....	27
10.3	Fehlerbeseitigung .....	28
11	Instandhaltung, Wartung, Reparatur .....	29
11.1	Instandhaltung .....	29
11.2	Wartung .....	29
11.3	Reparatur .....	29
11.4	Rücksendung .....	30
12	Reinigung .....	30
13	Entsorgung .....	30
14	Zubehör und Ersatzteile .....	30

# 1 Allgemeine Angaben

## 1.1 Hersteller

R. STAHL Schaltgeräte GmbH  
Am Bahnhof 30  
74638 Waldenburg  
Germany

Tel.: +49 7942 943-0  
Fax: +49 7942 943-4333  
Internet: r-stahl.com  
E-Mail: info@r-stahl.com

## 1.2 Angaben zur Betriebsanleitung

ID-Nr.: 162277 / 9440607310  
Publikationsnummer: 2021-10-12-BA00-III-de-08

Die Originalbetriebsanleitung ist die englische Ausgabe.  
Diese ist rechtsverbindlich in allen juristischen Angelegenheiten.

## 1.3 Weitere Dokumente

- Kopplungsbeschreibung IS1+ (Download unter r-stahl.com)
- Datenblatt

Dokumente in weiteren Sprachen, siehe r-stahl.com.

## 1.4 Konformität zu Normen und Bestimmungen

Zertifikate und EU-Konformitätserklärung, siehe r-stahl.com.

Das Gerät verfügt über eine IECEx-Zulassung. Zertifikat siehe IECEx-Homepage:  
<http://iecex.iec.ch/>

Weitere nationale Zertifikate stehen unter dem folgenden Link zum Download bereit:  
<https://r-stahl.com/de/global/support/downloads/>.

## 2 Erläuterung der Symbole

### 2.1 Symbole in der Betriebsanleitung

Symbol	Bedeutung
	Tipps und Empfehlungen zum Gebrauch des Geräts
	Gefahr durch explosionsfähige Atmosphäre
	Gefahr durch spannungsführende Teile



### 2.2 Warnhinweise

Warnhinweise unbedingt befolgen, um das konstruktive und durch den Betrieb bedingte Risiko zu minimieren. Die Warnhinweise sind wie folgt aufgebaut:

- Signalwort: GEFAHR, WARNUNG, VORSICHT, HINWEIS
- Art und Quelle der Gefahr/des Schadens
- Folgen der Gefahr
- Ergreifen von Gegenmaßnahmen zum Vermeiden der Gefahr bzw. des Schadens

	<b>GEFAHR</b>
	Gefahren für Personen Nichtbeachtung der Anweisung führt zu schweren oder tödlichen Verletzungen bei Personen.
	<b>WARNUNG</b>
	Gefahren für Personen Nichtbeachtung der Anweisung kann zu schweren oder tödlichen Verletzungen bei Personen führen.
	<b>VORSICHT</b>
	Gefahren für Personen Nichtbeachtung der Anweisung kann zu leichten Verletzungen bei Personen führen.
<b>HINWEIS</b>	
Vermeidung von Sachschaden Nichtbeachtung der Anweisung kann zu einem Sachschaden am Gerät und/oder seiner Umgebung führen.	

## 2.3 Symbole am Gerät

Symbol	Bedeutung
	CE-Kennzeichnung gemäß aktuell gültiger Richtlinie.
	Stromkreis gemäß Kennzeichnung für explosionsgefährdete Bereiche zertifiziert.
	Sicherheitshinweise, welche unerlässlich zur Kenntnis genommen werden müssen: Bei Geräten mit diesem Symbol sind die entsprechenden Daten und / oder die sicherheitsrelevanten Hinweise der Betriebsanleitung zu beachten!

## 3 Sicherheitshinweise

### 3.1 Aufbewahrung der Betriebsanleitung

- Betriebsanleitung sorgfältig lesen.
- Betriebsanleitung am Einbauort des Geräts aufbewahren.
- Mitgeltende Dokumente und Betriebsanleitungen der anzuschließenden Geräte beachten.

### 3.2 Qualifikation des Personals

Für die in dieser Betriebsanleitung beschriebenen Tätigkeiten ist eine entsprechend qualifizierte Fachkraft erforderlich. Dies gilt vor allem für Arbeiten in den Bereichen

- Projektierung
- Montage/Demontage des Geräts
- (Elektrische) Installation
- Inbetriebnahme
- Instandhaltung, Reparatur, Reinigung

Fachkräfte, die diese Tätigkeiten ausführen, müssen einen Kenntnisstand haben, der relevante nationale Normen und Bestimmungen umfasst.

Für Tätigkeiten in explosionsgefährdeten Bereichen sind weitere Kenntnisse erforderlich!

R. STAHL empfiehlt einen Kenntnisstand, der in folgenden Normen beschrieben wird:

- IEC/EN 60079-14 (Projektierung, Auswahl und Errichtung elektrischer Anlagen)
- IEC/EN 60079-17 (Prüfung und Instandhaltung elektrischer Anlagen)
- IEC/EN 60079-19 (Gerätoreparatur, Überholung und Regenerierung)

### 3.3 Sichere Verwendung

#### Vor der Montage

- Sicherheitshinweise in dieser Betriebsanleitung lesen und beachten!
- Sicherstellen, dass der Inhalt dieser Betriebsanleitung vom zuständigen Personal voll verstanden wurde.
- Gerät nur bestimmungsgemäß und nur für den zugelassenen Einsatzzweck verwenden.
- Bei Betriebsbedingungen, die durch die technischen Daten des Geräts nicht abgedeckt werden, unbedingt bei der R. STAHL Schaltgeräte GmbH rückfragen.
- Sicherstellen, dass das Gerät unbeschädigt ist.
- Für Schäden, die durch fehlerhaften oder unzulässigen Einsatz des Geräts sowie durch Nichtbeachtung dieser Betriebsanleitung entstehen, besteht keine Haftung.



#### Bei Montage und Installation

- Montage und Installation nur durch qualifizierte und autorisierte Personen (siehe Kapitel "Qualifikation des Personals") durchführen lassen.
- Gerät nur in Bereichen installieren, für die es aufgrund seiner Kennzeichnung geeignet ist.
- Bei Installation und im Betrieb die Angaben (Kennwerte und Bemessungsbedingungen) auf Typ- und Datenschildern sowie die Hinweisschilder am Gerät beachten.
- Vor Installation sicherstellen, dass das Gerät unbeschädigt ist.
- Stromkreise der Zündschutzart "Ex i", die mit Stromkreisen anderer Zündschutzarten betrieben wurden, dürfen danach nicht mehr als Stromkreise der Zündschutzart "Ex i" betrieben werden.
- Gerät bei Einsatz in Zone 1 in ein schützendes Gehäuse oder einen Schrank gemäß IEC/EN 60079-7 und IEC/EN 60079-11 einbauen, die jeweils eine geeignete Schutzart (mindestens IP54) aufweisen.
- Gerät bei Einsatz in Zone 2 in ein schützendes Gehäuse oder einen Schrank gemäß IEC/EN 60079-15 einbauen, die jeweils eine geeignete Schutzart (mindestens IP54) aufweisen.
- Gerät bei Einsatz in Zone 21, 22 in ein schützendes Gehäuse oder einen Schrank gemäß IEC/EN 60079-31 einbauen, die jeweils eine geeignete Schutzart (mindestens IP64) aufweisen.
- Bei der Installation nach NEC ist die Control drawing zu beachten!
- Eigensichere und nicht-eigensichere Stromkreise voneinander getrennt führen (siehe EN/IEC 60079-14), z.B. in unterschiedlichen Kabelkanälen.
- Zwischen den Anschlussstellen eigensicherer und nicht-eigensicherer Stromkreise Mindestabstand oder Fadenmaß von 50 mm, am besten um eine isolierende oder geerdete metallische Trennplatte herum vorsehen.
- Unbenutzte Leiter beim Sockel mit Kabelschwanz isolieren, z.B. durch Auflegen auf eine Ex-e-Klemme.
- Pro Sockel nur eine, zulässige Hilfsenergie anschließen. Dazu benötigte spezifische Daten zu den Anschlüssen im Kapitel "Technische Daten" nachschlagen.
- Schutzart IP30 an der Ex e Klemme sicherstellen.
- Nicht belegte Anschlussklemmen durch Berührungsschutz sichern.
- Nur Leiter mit einem maximalen Querschnitt von 2,5 mm<sup>2</sup> anschließen.
- Alle Geräte, die an RS485-Schnittstellen angeschlossen sind, galvanisch voneinander und von allen Stromkreisen trennen.

**Inbetriebnahme, Wartung, Reparatur**

- Inbetriebnahme und Instandsetzung nur durch qualifizierte und autorisierte Personen (siehe Kapitel "Qualifikation des Personals") durchführen lassen.
- Vor Inbetriebnahme sicherstellen, dass das Gerät unbeschädigt ist.
- Nur Wartungsarbeiten durchführen, die in dieser Betriebsanleitung beschrieben sind.
- Gerät nur mit feuchtem Tuch reinigen, um elektrostatische Aufladung zu vermeiden.

**3.4 Umbauten und Änderungen**

	<b>GEFAHR</b>
	<p>Explosionsgefahr durch Umbauten und Änderungen am Gerät! Nichtbeachten führt zu schweren oder tödlichen Verletzungen.</p> <ul style="list-style-type: none"> <li>• Gerät nicht umbauen oder verändern.</li> </ul>
	<p>Für Schäden, die durch Umbauten und Änderungen entstehen, besteht keine Haftung und keine Gewährleistung.</p>

**4 Funktion und Geräteaufbau**

	<b>GEFAHR</b>
	<p>Explosionsgefahr durch zweckentfremdete Verwendung! Nichtbeachten führt zu schweren oder tödlichen Verletzungen.</p> <ul style="list-style-type: none"> <li>• Gerät nur entsprechend den in dieser Betriebsanleitung festgelegten Betriebsbedingungen verwenden.</li> <li>• Gerät nur entsprechend dem in dieser Betriebsanleitung genannten Einsatzzweck verwenden.</li> </ul>

## 4.1 Funktion

### Funktion

Das CPU & Power Modul (CPM) 9440/22 hat die Funktion eines Gateways zwischen dem internen Bus einer IS1+ Feldstation und dem Feldbus, der die Feldstation einfach oder redundant mit dem Automatisierungssystem verbindet.

### Einsatzbereich

Das CPM ist für IS1+ Feldstationen bestimmt und darf in explosionsgefährdeten Bereichen der Zone 1 / Division 1, Zone 2 / Division 2 oder Zone 21 und 22 sowie im sicheren Bereich installiert werden.

### Arbeitsweise

Das CPM enthält ein Netzteil zur eigenen Stromversorgung als auch für die Versorgung der I/O-Module und der Feldstromkreise. Das Netzteil ist mit einer Unterspannungs-Überwachung ausgestattet. Die Stromversorgung der I/O-Module erfolgt über die BusRail. Die Kommunikation mit den I/O Modulen erfolgt über die Adress- und Datenleitungen der BusRail. Die Schnittstelle des CPU & Power Moduls zum internen Datenbus der BusRail ist redundant ausgeführt.

## 4.2 Geräteaufbau

	#	Geräteelement	Beschreibung
	1	Abdeckklappe	Abdeckklappe zur Sicherstellung der Schutzart IP30 (geöffnet)
	2	Klemme	Ex e Klemme (nur bei Sockel 9490/11-12)
	3	Rasthebel	Rasthebel zum Entfernen des Moduls vom Sockel
	4	Buchse	Buchse für Modul
	5	Klemmschraube	Klemmschraube für DIN-Schiene
	6	Buchse	Buchse für Modul
	7	Rasthebel	Rasthebel zum Entfernen des Moduls vom Sockel
	8	LCD-Anzeige	LCD-Anzeige
	9	LED	LED zur Status- bzw. Fehleranzeige (weitere Informationen siehe Kapitel "Fehlerbeseitigung")
	10	Tasten	Tasten <up>, <down>
	11	Sub-D-Buchse X1	Prozessbus, primär
	12	Sub-D-Buchse X2	Prozessbus, redundant (nur mit PROFIBUS DP nutzbar!)
	13	Sub-D-Buchse X3	ServiceBus
	14	Kabelschwanz	nur bei Sockel 9490/13-12
		Conduit Hub	nur bei Sockel 9490/12-12
15	CPU & Power Modul	CPU & Power Modul	



## 5 Technische Daten

### Explosionsschutz

#### Global (IECEX)

Gas	IECEX KEM 08.0038X
9440/22-01-.1:	Ex db [ia Ga] [ib Gb] IIC T4 Gb
9490/11-12:	Ex db eb [ia Ga] [ib Gb] IIC T4 Gb
9490/13-12:	Ex db mb [ia Ga] [ib Gb] IIC T4 Gb

#### Europa (ATEX)

Gas	KEMA 02 ATEX 1333 X
9440/22-01-.1:	⊕ II 2 G Ex db [ia Ga] [ib Gb] IIC T4 Gb
9490/11-12:	⊕ II 2 G Ex db eb [ia Ga] [ib Gb] IIC T4 Gb
9490/13-12:	⊕ II 2 G Ex db mb [ia ga] [ib gb] IIC T4 Gb

### Bescheinigungen und Zertifikate

Bescheinigungen	IECEX, ATEX, EAC (TR), Brasilien (INMETRO), Indien (PESO), Kanada (FM), USA (FM)
Schiffszertifikate	EU RO Mutual Recognition (inkl. ABS, BV, CCS, CRS, DNV GL, IRS, KR, LR, ClassNK, PRS, RINA, RS)

### Weitere Parameter

Weitere Angaben	siehe jeweilige Bescheinigung und Betriebsanleitung
-----------------	---

### Sicherheitstechnische Daten

Maximale Ausgangsspannung	$U_{out} = 26,2 \text{ V}$ für Stromversorgung der I/O Module
Anschluss an eigensicheren RS485-IS Feldbus	Global (IECEX): IECEX PTB 11.0027, Ex ib IIC T4 Gb Europa (ATEX): PTB 04 ATEX 2089, ⊕ II 2 G Ex ib IIC T4 Gb
Höchstwerte für Feldbus und ServiceBus (RS485-IS)	
Maximale Spannung $U_o$	3,7 V
Maximale Spannung $U_i$	+/- 4,2 V
Maximaler Strom $I_o$	134 mA
Maximale Leistung $P_o$	124 mW
Maximale Kapazität $C_o$ für IIC	1000 $\mu\text{F}$
Maximale Induktivität $L_o$ für IIC	1,9 mH

**Technische Daten**

Ausführung	9440/22-01-11 (24 V DC)	9440/22-01-21 (90 ... 253 V AC)
<b>Elektrische Daten</b>		
Hilfsenergie		
Nennspannung	24 V DC	120 V / 230 V AC
Spannungsbereich	20 ... 35 V DC	90 ... 253 V AC
Netzfrequenz	–	50 / 60 Hz
Frequenzbereich	–	45 ... 66 Hz
Stromaufnahme		
ohne I/O Module	ca. 0,21 A bei 24 V DC	ca. 25 mA bei 230 V AC, ca. 48 mA bei 120 V AC
mit 8 I/O Modulen	ca. 2,5 A bei 24 V DC	ca. 0,4 A bei 230 V AC, ca. 0,8 A bei 120 V AC
Verlustleistung		
ohne I/O Module	5 W	8,4 W
je I/O Modul	ca. 1,4 W	ca. 1 W
Verpolschutz	ja	entfällt
Unterspannungsüberwachung	ja	ja
Schnittstellen		
Feldbus, Feldbus redundant und ServiceBus		
Schnittstelle	RS485-IS nach Profibus Spezifikation	
Leitungslänge / Übertragungsrate		
Kupferkabel	1200 m bei 9,6 ... 93,75 kbit/s 1000 m bei 187,5 kbit/s 400 m bei 500 kbit/s 200 m bei 1,5 Mbit/s	
Lichtwellenleiter	ca. 2000 m bei 1,5 Mbit/s	
ServiceBus	1200 m bei 9,6 kbit/s	
Leistungsabschluss	gespeister Widerstand (Abschlusswiderstand im Sub-D Stecker, siehe Zubehör)	
Adressbereich	0 ... 127	
Redundanz	Systemredundanz	

## Technische Daten

Profibus	
Versionen	DP V0, DP V1, DP V1 HART
Übertragungsgeschwindigkeit	9,6 kbit/s ... 1,5 Mbit/s
Datenübertragung	ca. 40 16-Bit-Worte / ms (zyklisch, netto bei 1,5 Mbit/s)
Modbus RTU	
Übertragungsgeschwindigkeit	9,6 ... 38,4 kbit/s
Datenübertragung	ca. 1000 16-Bit-Register/s (bei 38,4 kbit/s)
Funktionen	Read, Write; siehe Kopplungsbeschreibung Modbus RTU
Kennwerte	
Max. interne Signalverzögerung bei 8 I/O Modulen (ohne Modulverzögerung)	
für Digital Module	7 ms
für Analog Module	10 ms
Bediener-Schnittstelle	
Software	IS1+ Geräte DTM oder IS Wizard
Betrieb	LED "RUN", grün
Fehler	LED "ERR", rot
LCD-Anzeige	2 x 16 Zeichen
Einstellungen	Busadresse
Anzeigen	Busadresse, Alarme / Fehler, Informationen (Typ, Revision usw.) für die Ebenen Feldstation, Module und Signale, Werte der Eingänge und Ausgänge
Diagnose und Parametrierung	
Funktionen	<ul style="list-style-type: none"> <li>• Konfigurationsdaten und Parameter in IS1+ Feldstationen laden oder rücklesen</li> <li>• Eingänge lesen</li> <li>• Ausgänge lesen und schreiben</li> <li>• Diagnosedaten übertragen (z.B. Konfig-Fehler, Hardware-Fehler, Signal-Fehler)</li> <li>• HART Kommandos von / zu HART Feldgeräten übertragen</li> </ul>
Anschließbare Softwarepakete	<ul style="list-style-type: none"> <li>• IS Wizard (über R. STAHL ServiceBus)</li> <li>• R. STAHL DTM</li> <li>• AMS von Emerson Process Management</li> <li>• PDM von Siemens</li> <li>• PRM und Fieldmate von Yokogawa</li> <li>• FieldCare von Endress + Hauser</li> <li>• FDM von Honeywell</li> <li>• etc.</li> </ul>

**Technische Daten**

Stromversorgung für I/O Module über die BusRail	
Spannungsbereich	22,5 ... 26,2 V DC
Max. Strom	2 A
Max. Anzahl I/O Module	8
Redundante Versorgung der I/O Module	ja (mit Dioden entkoppelt)
Unterspannungsüberwachung	ja
Galvanische Trennung	
zwischen Hilfsenergie und Systemkomponenten	1500 V AC
zwischen Feldbus-/ServiceBus-Schnittstelle und Systemkomponenten	500 V AC
zwischen zwei Bus-Schnittstellen	500 V AC
Elektromagnetische Verträglichkeit	Geprüft nach folgenden Normen und Vorschriften: EN 61326-1, EN 61000-4-1...6, NAMUR NE 21

**Umgebungsbedingungen**

Umgebungstemperatur	-20 ... +65 °C
Lagertemperatur	-40 ... +70 °C
Maximale relative Luftfeuchte	95 % (keine Betauung)
Verwendung in Höhe	< 2000 m
Schock, halbsinusförmig (IEC/EN 60068-2-27)	15 g (3 Schocks pro Achse und Richtung)
Vibration, sinusförmig (IEC/EN 60068-2-6)	1 g im Frequenzbereich 10 ... 500 Hz 2 g im Frequenzbereich 45 ... 100 Hz

**Technische Daten****Mechanische Daten**

<b>Anschluss</b>		
Feldbus RS485	Sub-D Buchse 9-polig	
ServiceBus RS485	Sub-D Buchse 9-polig	
<b>Hilfsenergie</b>		
	Socket 9490/11-12	Ex e Klemmen 4,0 mm <sup>2</sup>
	Socket 9490/13-12	Kabelschwanz, 5 m, 1 mm <sup>2</sup> je Ader
	Socket 9490/12-12	Conduit
<b>Schutzart (IEC 60529)</b>		
Module	IP30	
Anschlüsse	IP20	
Modulgehäuse	Polyamid 6GF	
Brandfestigkeit (UL 94)	HB	

**Montage / Installation**

<b>Einbaubedingungen</b>	
Montageart	auf 35-mm-DIN-Schiene NS 35/15
Einbaulage	waagrecht und senkrecht

Weitere technische Daten, siehe [r-stahl.com](http://r-stahl.com).

## 6 Projektierung

### HINWEIS

Ausfall der installierten Geräte im Schaltschrank durch zu hohe Umgebungstemperatur!

Nichtbeachten kann zu Sachschäden führen.

- Schaltschrank so aufbauen und einrichten, dass er immer innerhalb des zulässigen Temperaturbereichs betrieben wird.
- "Installationsanleitung Schaltschrank" sorgfältig beachten.

Bei der Projektierung folgende Bedingungen sicherstellen:

- Gerät zur bestimmungsgemäßen Verwendung auf der IS1+ BusRail installieren.
- Am Gerät bis zu 8 I/O-Module betreiben.
- Der Betrieb des Geräts ist nur in drei Montagelagen zulässig (siehe auch Kapitel "Montage / Demontage auf BusRail").
- Das primäre Gerät auf dem ersten Steckplatz der BusRail montieren.
- Das redundante Gerät (optional) auf dem zweiten Steckplatz der BusRail montieren.
- Die Hutschiene der BusRail mit dem Potentialausgleich des explosionsgefährdeten Bereichs verbinden.
- An den angeschlossenen Hilfsenergie-Stromkreisen nur im spannungsfreien Zustand arbeiten.
- Beim Einsatz in explosionsgefährdeten Bereichen müssen zwischen den Feldbus-Anschlüssen (X1, X2, X3) und dem Automatisierungssystem geeignete Feldbus-Trennübertrager eingesetzt werden (z.B. R. STAHL Reihe 9185 oder 9186). Dies gilt auch dann, wenn das CPU & Power Modul im sicheren Bereich installiert ist aber Feldbus-Stromkreise der angeschlossenen I/O-Module in den explosionsgefährdeten Bereich führen.

## 6.1 Anschlussbelegung Hilfsenergieanschluss

Für den Hilfsenergieanschluss stehen 3 verschiedene Sockel zur Verfügung:

- 9490/11-12: Anschluss über Ex e Klemme
- 9490/13-12: Anschluss über Kabelschwanz
- 9490/12-12: Anschluss über Conduit

Ex e Klemme Klemmen Nr.	Kabelschwanz Leiter Nr.	Funktion
1	1	+24 V DC
2	2	0 V
4	2	N (90 ... 253 V AC)
6	3	L (90 ... 253 V AC)
3, 5, 7, 8, 9, 10, 11, 12, 13, 14, 15, 16	–	keine Leitungen anschließen

## 6.2 Anschlussbelegung Sub-D-Buchsen X1, X2, X3

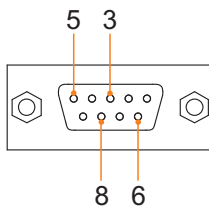

12224E00

Pin-Nr.	Funktion	Beschreibung
3	RxD/TxD (+)	Daten B (+)
5	GND	Bezugspotential für Geräteschnittstelle
6	PWR (+)	Versorgungsspannung (Gerät)
8	RxD/TxD (-)	Daten A (-)
übrige Pins	–	nicht angeschlossen

## 7 Transport und Lagerung

- Gerät nur in Originalverpackung transportieren und lagern.
- Gerät trocken (keine Befeuchtung) und erschütterungsfrei lagern.
- Gerät nicht stürzen.

## 8 Montage und Installation

Das Gerät ist für den Einsatz in gasexplosionsgefährdeten Bereichen der Zonen 1/ Division 1 und Zone 2/Division 2, in staubexplosionsgefährdeten Bereichen der Zonen 21 und 22 sowie auch im sicheren Bereich zugelassen.

<b>GEFAHR</b>	
	<p>Explosionsgefahr durch falsche Installation des Geräts! Nichtbeachten führt zu schweren oder tödlichen Verletzungen.</p> <ul style="list-style-type: none"><li>• Installation strikt nach Anleitung und unter Berücksichtigung der nationalen Sicherheits- und Unfallverhütungsvorschriften durchführen, damit der Explosionsschutz erhalten bleibt.</li><li>• Das elektrische Gerät so auswählen bzw. installieren, dass der Explosionsschutz aufgrund äußerer Einflüsse nicht beeinträchtigt wird, z.B. Druckbedingungen, chemische, mechanische, thermische, elektrische Einflüsse sowie Schwingungen, Feuchte, Korrosion (siehe IEC/EN 60079-14).</li><li>• Gerät nur durch geschultes und mit den einschlägigen Normen vertrautes Fachpersonal installieren lassen.</li></ul>



## 8.1 Maßangaben / Befestigungsmaße

Maßzeichnungen (alle Maße in mm [Zoll]) – Änderungen vorbehalten

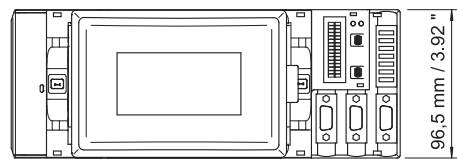
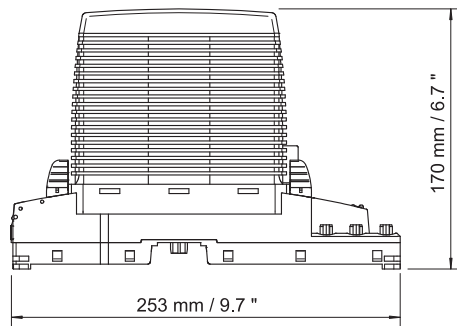

**9490/11-12**  
CPU & Power Modul für Zone 1  
mit Anschluss über Ex e Klemmen

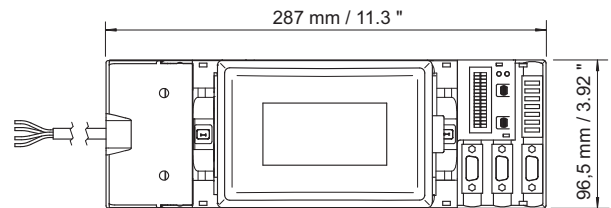
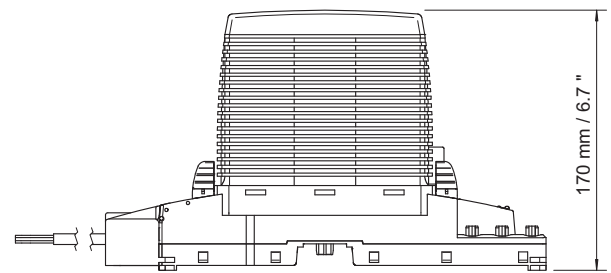

09877E00

07762E00

**9490/12-12 nur FM**  
CPU & Power Modul für Division 1  
mit Anschluss über Conduit

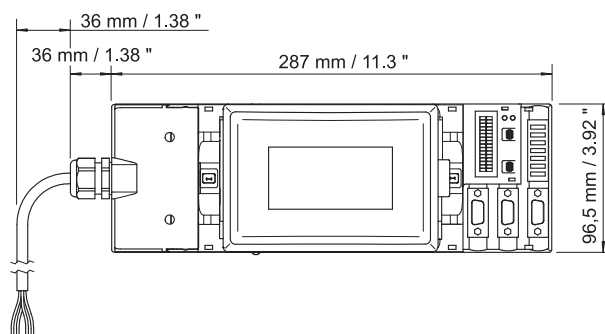
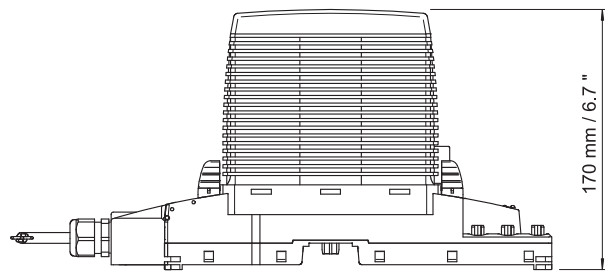

07760E00

**9490/13-12**  
CPU & Power Modul für Zone 1  
mit Anschluss über Kabelschwanz

## 8.2 Montage / Demontage, Gebrauchslage

### 8.2.1 Montage / Demontage auf BusRail

#### HINWEIS

Fehlfunktion oder Geräteschaden durch unsachgemäße Montage.

Nichtbeachten kann Sachschaden verursachen!

- Gerät ausschließlich vertikal montieren, mit Lese-Richtung der LCD-Anzeige wahlweise von unten, von links oder von rechts.

#### Montage des Sockels auf BusRail

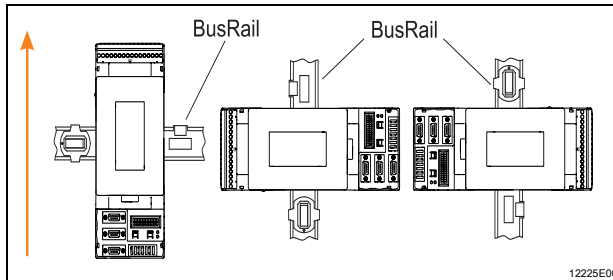

- Sockel senkrecht auf ersten Steckplatz der BusRail aufsetzen.
- Sockel durch leichtes Drücken einrasten.

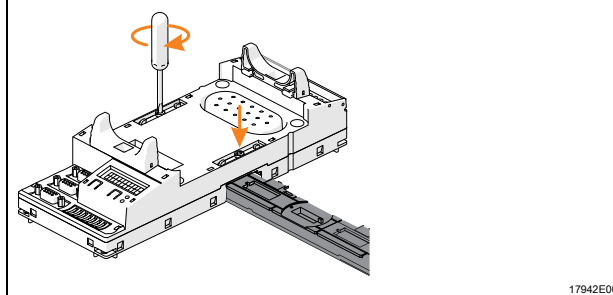

- Sockel mit den Klemmschrauben an DIN-Schiene befestigen (Anzugsdrehmoment 0,5 ... 0,6 mm).

#### Montage / Stecken des CPM Moduls auf Sockel

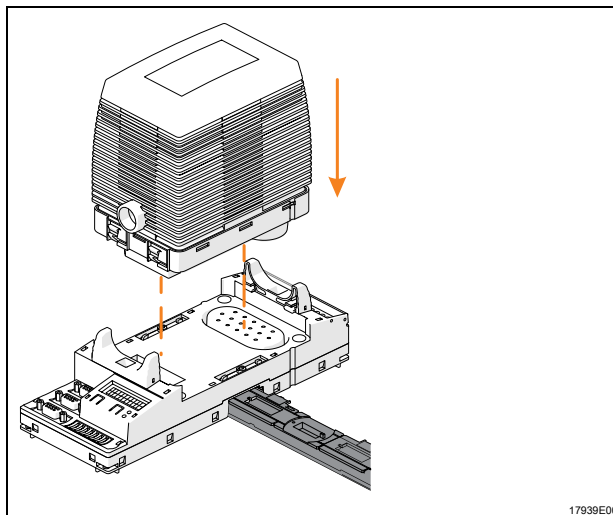

- CPM senkrecht auf den Sockel aufsetzen, dabei die Stecker am Modul auf den Buchsen des Sockels ausrichten.
- CPM durch Drücken einrasten.
- Sicherstellen, dass der CPM beidseitig korrekt eingerastet ist. Dazu den CPM vorne und hinten nochmals von oben herunterdrücken.

## 8.2.2 Demontage / Modulwechsel

	<b>WARNUNG</b>
<p>Stromschlaggefahr durch spannungsführende Klemme! Nichtbeachten kann zu schweren Verletzungen und Sachschäden führen.</p> <ul style="list-style-type: none"> <li>An den Ex e Klemmen oder am Kabelschwanz nur im spannungsfreien Zustand arbeiten.</li> </ul>	

## Austausch des CPM Moduls

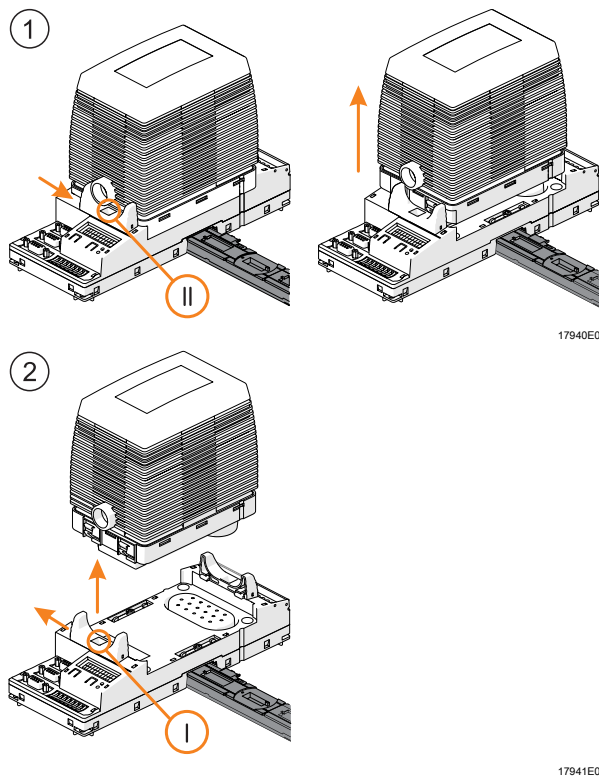
 <p>17940E00</p> <p>17941E00</p>	<ul style="list-style-type: none"> <li>• Beide Rasthebel in Position "II" schieben, Abbildung 1.</li> <li>• Modul senkrecht bis zum Anschlag aus dem Sockel ziehen.</li> <li>• Beide Rasthebel in Position "I" schieben, Abbildung 2.</li> <li>• Modul senkrecht aus dem Sockel entfernen.</li> <li>• Neues Modul senkrecht auf Sockel aufsetzen.</li> <li>• Modul durch Drücken einrasten.</li> <li>• Sicherstellen, dass der CPM beidseitig korrekt eingerastet ist. Dazu den CPM vorne und hinten nochmals von oben herunterdrücken.</li> </ul>
--	--

### Austausch des Sockels

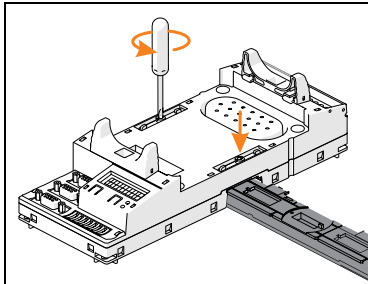

17943E00

- CPM entnehmen, siehe Kapitel "Austausch des CPM Moduls".
- Hilfsenergie von Ex e Klemme entfernen bzw. Kabelschwanz von Hilfsenergie trennen.
- Feldbus-Anschlüsse von den Sub-D-Buchsen entfernen.
- Klemmschrauben des Sockels lösen.
- Sockel senkrecht von BusRail abziehen.
- Neuen Sockel senkrecht auf BusRail setzen, siehe auch Kapitel "Montage des Sockels auf BusRail".
- Neues CPM Modul auf Sockel stecken, siehe auch Kapitel "Montage / Stecken des CPM Moduls auf Sockel".
- Feldbusse wieder an Sub-D-Buchsen anschließen.
- Hilfsenergie wieder anschließen.

## 8.3 Installation



Bei Betrieb unter erschwerten Bedingungen wie insbesondere auf Schiffen sind zusätzliche Maßnahmen zur korrekten Installation je nach Einsatzort zu treffen. Weitere Informationen und Anweisungen hierzu erhalten Sie gerne auf Anfrage von Ihrem zuständigen Vertriebskontakt.

### 8.3.1 Hilfsenergie anschließen

Für die Hilfsenergie stehen drei verschiedene Sockel zur Verfügung:

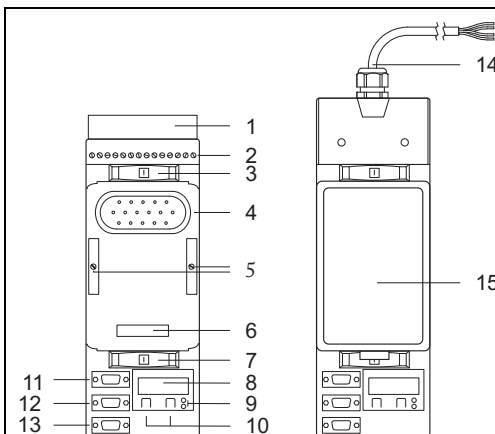

12223E00

- 9490/11-12: Anschluss über Ex e Klemmen (2)
- 9490/13-12: Anschluss über Kabelschwanz (14)
- 9490/12-12: Anschluss über Conduit (14)

	<ul style="list-style-type: none"> <li>• Am Sockel darf entweder nur die Hilfsenergie 20 ... 35 V DC für das CPM 9440/22-01-11 oder 90 ... 230 V AC für das CPM 9440/22-01-21 angeschlossen werden. Der gleichzeitige Anschluss beider Hilfsenergien ist nicht zulässig.</li> <li>• Beim Sockel mit Kabelschwanz müssen die nicht benutzten Leiter isoliert werden (z.B. durch Auflegen auf eine Ex e Klemme).</li> </ul>
---	---

### 8.3.2 Feldbus anschließen

- Primären Feldbus an Sub-D-Buchse X1 anschließen.
- Gegebenenfalls redundanten Feldbus an Sub-D-Buchse X2 anschließen (nur mit Profibus DP möglich!).
- Sub-D-Stecker mit Schrauben gegen Lockern sichern (Anzugsdrehmoment 0,5 ... 0,6 Nm).

### 8.3.3 ServiceBus anschließen

- ServiceBus an Sub-D-Buchse X3 anschließen.
- Sub-D-Stecker mit Schrauben gegen Lockern sichern (Anzugsdrehmoment 0,5 ... 0,6 Nm).

## 9 Parametrierung und Inbetriebnahme

	GEFAHR
Explosionsgefahr durch fehlerhafte Installation! Nichtbeachten führt zu schweren oder tödlichen Verletzungen.	
<ul style="list-style-type: none"> <li>• Gerät vor der Inbetriebnahme auf korrekte Installation prüfen.</li> <li>• Nationale Bestimmungen einhalten.</li> </ul>	

Vor Inbetriebnahme Folgendes sicherstellen:

- Vorschriftsmäßige Installation des Gerätes.
- Richtiger Anschluss der Kabel.
- Keine Schäden am Gerät und an Anschlusskabeln.
- Fester Sitz der Schrauben an den Klemmen.  
Richtiges Anzugsdrehmoment: 0,5 ... 0,6 Nm.

### 9.1 Parametrierungen

Die Parametrierung und Inbetriebnahme des CPM und der angeschlossenen I/O Module erfolgt über das Automatisierungssystem und den ServiceBus (optional).

Nur die Feldbusadresse des CPM muss direkt am Sockel eingestellt werden.

Über die LCD-Anzeige mit Tasten im Sockel lassen sich

- die Feldbusadresse des Geräts einstellen
- Informationen über das Gerät und die auf der BusRail installierten I/O Modulen anzeigen (siehe Kapitel "Anzeige").

### 9.1.1 LCD-Anzeigen Zur Anzeige eines bestimmten Moduls wechseln

LCD-Anzeige	Einstellungen
<pre>FBAdr  FB  I/O 120    OK  OK 12258E00</pre>	<ul style="list-style-type: none"> <li>Ausgangsanzeige (links dargestellt)</li> </ul>
<pre>CPM      active 9440/15-01-11 12259E00</pre>	<ul style="list-style-type: none"> <li>Tasten ▲ und ▼ gleichzeitig drücken, um von Systemebene in Modulebene zu wechseln. Es erscheint folgende Anzeige (links dargestellt).</li> <li>Mit der Taste ▲ und ▼ gewünschtes Modul auswählen.</li> </ul>
	<ul style="list-style-type: none"> <li>Tasten ▲ und ▼ gleichzeitig drücken. Die Anzeige wechselt in die Informationsebene.</li> <li>Mit der Taste ▲ oder ▼ zwischen verschiedenen LCD-Anzeigen wechseln (siehe folgende Tabelle).</li> </ul>

### Anzeige Status-Informationen der CPM

LCD-Anzeige	Anzeige/Funktion																				
<pre>CPM      active FB addr : 5 12260E00</pre>	Zustand und Feldbus-Adresse des Geräts.																				
<pre>CPM information Modbus  V10-00 12264E00</pre>	Kopplungsart																				
<pre>CPM      status config/para fail 12265E00</pre>	<p>Status des Geräts.</p> <p>Mögliche Status-Informationen:</p> <table border="1"> <thead> <tr> <th>Status-Information in LCD-Anzeige</th> <th>Bedeutung</th> </tr> </thead> <tbody> <tr> <td>no error</td> <td>kein Fehler</td> </tr> <tr> <td>hardware fail (1)</td> <td>Hardwarefehler gefunden</td> </tr> <tr> <td>hardware fail (2)</td> <td>falsche Hardware-Kennung</td> </tr> <tr> <td>hardware fail (3)</td> <td>keine Kommunikation zwischen CPR und IOP</td> </tr> <tr> <td>DataExch AS</td> <td>Data Exchange mit Automatisierungssystem, Konfiguration durch Profibus</td> </tr> <tr> <td>DataExch AS (2)</td> <td>Data Exchange mit dem Automatisierungssystem</td> </tr> <tr> <td>no DataExch</td> <td>kein Datenaustausch</td> </tr> <tr> <td>config/para fail</td> <td>Konfigurations- oder Parameterfehler</td> </tr> <tr> <td>quit DataExch</td> <td>kein Datenaustausch mehr</td> </tr> </tbody> </table>	Status-Information in LCD-Anzeige	Bedeutung	no error	kein Fehler	hardware fail (1)	Hardwarefehler gefunden	hardware fail (2)	falsche Hardware-Kennung	hardware fail (3)	keine Kommunikation zwischen CPR und IOP	DataExch AS	Data Exchange mit Automatisierungssystem, Konfiguration durch Profibus	DataExch AS (2)	Data Exchange mit dem Automatisierungssystem	no DataExch	kein Datenaustausch	config/para fail	Konfigurations- oder Parameterfehler	quit DataExch	kein Datenaustausch mehr
Status-Information in LCD-Anzeige	Bedeutung																				
no error	kein Fehler																				
hardware fail (1)	Hardwarefehler gefunden																				
hardware fail (2)	falsche Hardware-Kennung																				
hardware fail (3)	keine Kommunikation zwischen CPR und IOP																				
DataExch AS	Data Exchange mit Automatisierungssystem, Konfiguration durch Profibus																				
DataExch AS (2)	Data Exchange mit dem Automatisierungssystem																				
no DataExch	kein Datenaustausch																				
config/para fail	Konfigurations- oder Parameterfehler																				
quit DataExch	kein Datenaustausch mehr																				
<pre>CPM      active back 12266E00</pre>	Tasten ▲ und ▼ gleichzeitig drücken. Wechsel zurück in die Modulebene des Geräts.																				
<pre>CPM      active exit menu 12267E00</pre>	Tasten ▲ und ▼ gleichzeitig drücken. Wechsel zurück zur Hauptanzeige des Geräts.																				

### Zur Anzeige eines bestimmten Moduls wechseln

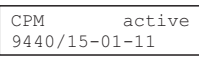
LCD-Anzeige	Einstellungen
 <small>12258E00</small>	<ul style="list-style-type: none"> <li>Ausgangsanzeige (links dargestellt)</li> </ul>
 <small>12259E00</small>	<ul style="list-style-type: none"> <li>Tasten ▲ und ▼ drücken, um von Systemebene in Modulebene zu wechseln. Es erscheint folgende Anzeige (links dargestellt).</li> <li>Mit der Taste ▲ und ▼ gewünschtes Modul auswählen.</li> </ul>
	<ul style="list-style-type: none"> <li>Tasten ▲ und ▼ gleichzeitig drücken. Die Anzeige wechselt in die Informations-/Serviceebene.</li> </ul>

### Anzeige Status-Informationen des I/O Moduls

	<p>Die folgenden Anzeigen sind für alle I/O Module gleich aufgebaut.</p>
---	--

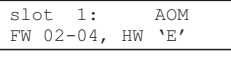
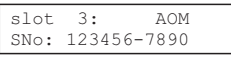
LCD-Anzeige	Anzeige/Funktion																								
 <small>12268E00</small>	<p>Anzeige des Steckplatzes, des Modultyps und des Modulzustands.</p> <p>Mögliche Modulzustände:</p> <table border="1"> <thead> <tr> <th>Status-Information in LCD-Anzeige</th> <th>Bedeutung</th> <th>Prio</th> </tr> </thead> <tbody> <tr> <td>IOM no response</td> <td>Kommunikation mit dem Modul ist nicht möglich. Modul ist defekt, nicht gesteckt oder beide BusRail bzw. das BusRail-Verbindungskabel sind gestört</td> <td>1</td> </tr> <tr> <td>hardware failure</td> <td>Modul meldet Hardwarefehler</td> <td>2</td> </tr> <tr> <td>conf unequal mod</td> <td>Konfigurationsfehler oder falsches Modul gesteckt</td> <td>3</td> </tr> <tr> <td>HW disable outp.</td> <td>Ausgänge durch externen Schalter (Anlagen Aus) abgeschaltet (nur bei DOM 9475/2)</td> <td>4</td> </tr> <tr> <td>prim. Rail fail</td> <td>keine Kommunikation über primären BusRail-Datenbus</td> <td>5</td> </tr> <tr> <td>red. Rail fail</td> <td>keine Kommunikation über redundanten BusRail-Datenbus</td> <td>5</td> </tr> <tr> <td>module OK/mode: x</td> <td>Modul in Ordnung. Kein Modulfehler. Signalfehler können trotzdem vorhanden sein. Zusätzlich wird die konfigurierte Betriebsart (mode:x) angezeigt</td> <td>6</td> </tr> </tbody> </table> <p>Bei mehreren Fehlern wird nur der Fehler mit der höchsten Priorität angezeigt. Nach Beheben dieses Fehlers wird der Fehler mit der nächsthöheren Priorität angezeigt.</p>	Status-Information in LCD-Anzeige	Bedeutung	Prio	IOM no response	Kommunikation mit dem Modul ist nicht möglich. Modul ist defekt, nicht gesteckt oder beide BusRail bzw. das BusRail-Verbindungskabel sind gestört	1	hardware failure	Modul meldet Hardwarefehler	2	conf unequal mod	Konfigurationsfehler oder falsches Modul gesteckt	3	HW disable outp.	Ausgänge durch externen Schalter (Anlagen Aus) abgeschaltet (nur bei DOM 9475/2)	4	prim. Rail fail	keine Kommunikation über primären BusRail-Datenbus	5	red. Rail fail	keine Kommunikation über redundanten BusRail-Datenbus	5	module OK/mode: x	Modul in Ordnung. Kein Modulfehler. Signalfehler können trotzdem vorhanden sein. Zusätzlich wird die konfigurierte Betriebsart (mode:x) angezeigt	6
Status-Information in LCD-Anzeige	Bedeutung	Prio																							
IOM no response	Kommunikation mit dem Modul ist nicht möglich. Modul ist defekt, nicht gesteckt oder beide BusRail bzw. das BusRail-Verbindungskabel sind gestört	1																							
hardware failure	Modul meldet Hardwarefehler	2																							
conf unequal mod	Konfigurationsfehler oder falsches Modul gesteckt	3																							
HW disable outp.	Ausgänge durch externen Schalter (Anlagen Aus) abgeschaltet (nur bei DOM 9475/2)	4																							
prim. Rail fail	keine Kommunikation über primären BusRail-Datenbus	5																							
red. Rail fail	keine Kommunikation über redundanten BusRail-Datenbus	5																							
module OK/mode: x	Modul in Ordnung. Kein Modulfehler. Signalfehler können trotzdem vorhanden sein. Zusätzlich wird die konfigurierte Betriebsart (mode:x) angezeigt	6																							
 <small>12269E00</small>	Anzeige der Firmware- und der Hardware-Revision.																								
 <small>12270E00</small>	Anzeige der Seriennummer.																								

### Digital Modul

Zusätzlich zu den allgemeinen Anzeigen gibt es bei Digital Modulen noch folgende Anzeigen:

LCD-Anzeige	Anzeige/Funktion
<pre>slot 1:   DOM safety position 12272E00</pre>	Ohne Ausgabedaten wird Sicherheitszustand der Ausgänge angezeigt. (nur bei Output Module)
<pre>slot 1:   DOM . . † . . ≲ . . 12273E00</pre>	I/O Fehler. † : Drahtbruch ≲ : Kurzschluss
<pre>1 1 0 0 1 0 1 1 . . † . . ≲ . . 12274E00</pre>	I/O Daten und Fehler.
<pre>slot 2:   DIM 1100011011011010 12276E00</pre>	I/O Daten. Der Wert für Kanal 0 steht links, der für Kanal 15 rechts.
<pre>s 3/14:   0 Counter: reset 12279E00</pre>	Anzeige des Zähler-/Frequenzwertes und der Steuerbits "start" und "reset" für Kanal 14. (nur bei Input Modul)
<pre>s 3/15:   100 Counter: start 12280E00</pre>	Anzeige des Zähler-/Frequenzwertes und der Steuerbits "start" und "reset" für Kanal 15. (nur bei Input Modul)

### Analog Modul

Zusätzlich zu den allgemeinen Anzeigen gibt es bei dem Analog Modul noch die folgende Anzeige, siehe Tabelle.

Bei Verwendung von HART beim Modul 9468 gibt es noch zusätzliche Menüpunkte (siehe "Analog Modul mit HART")

LCD-Anzeige	Anzeige/Funktion
<pre>slot 3:   AOM ■ . ■ . ■ . s s 12281E00</pre>	I/O Daten. Der Wert für Kanal 0 steht links, der für Kanal 7 rechts. Bei Ausgängen, die noch keine gültigen I/O Daten erhalten haben, wird die Sicherheitsstellung "s" angezeigt.
<pre>slot 3:   AOM . . † . . ≲ . . 12282E00</pre>	I/O Fehler. † : Drahtbruch ≲ : Kurzschluss
<pre>■ . ■ . ■ . s s . . † . . ≲ . . 12283E00</pre>	I/O Daten und Fehler.
<pre>slot 3:   AOM single I/O 12284E00</pre>	Anzeige der I/O Daten für einzelne Kanäle. Aufruf des Untermenüs durch gleichzeitiges Drücken der Tasten ▲ und ▼ .
<pre>slot 3:   AOM I/O 0: safety pos 12285E00</pre>	Anzeige von I/O Fehler oder I/O Daten. Ist kein I/O Wert vorhanden, wird die Sicherheitsstellung angezeigt. Wechseln zwischen Kanälen durch gleichzeitiges Drücken der Tasten ▲ und ▼ .



### Analog Modul mit HART

Für das HART Modul 9468 können die HART PV dargestellt werden.  
 Das Untermenü erscheint nur, wenn die Analog Module für die Übertragung von HART PV konfiguriert sind.  
 Es werden nur die konfigurierten HART PV angezeigt.

LCD-Anzeige	Anzeige/Funktion
<p>slot 4: AIM HART PV 12286E00</p>	Menü zur Anzeige der HART PV. Aufruf der Untermenüs durch gleichzeitiges Drücken von ▲ und ▼ .
<p>slot 4: AIM PV 1: -16.234 12287E00</p>	Anzeige der konfigurierten PV. Betriebsart 1 = 4 PV, Betriebsart 2 = 8 PV. Wechseln der PV durch Drücken der Taste ▲ oder ▼ .
<p>slot 4: AIM PV 3: #.### 12288E00</p>	Anzeige von "not a number".

### Temperatur Input Modul

Zusätzlich zu den allgemeinen Anzeigen gibt es bei dem Temperatur Input Modul noch die folgende Anzeige:

LCD-Anzeige	Anzeige/Funktion
<p>slot 3: AOM ■■■■■■■■ s s 12281E00</p>	I/O Daten. Der Wert für Kanal 0 steht links, der für Kanal 7 rechts. Bei Ausgängen, die noch keine gültigen I/O Daten erhalten haben, wird die Sicherheitsstellung "s" angezeigt.
<p>slot 3: AOM ..⚡..⚡.. 12282E00</p>	I/O Fehler. ⚡ : Drahtbruch ⚡ : Kurzschluss
<p>■■■■■■■■ s s ..⚡..⚡.. 12283E00</p>	I/O Daten und Fehler.
<p>slot 4: AIM 2w calib 17025E00</p>	Anzeige Kalibrierung

## 9.1.2 StartUp

Anzeige	Einstellungen
<p>FBAdr FB I/O 120 OK OK 12258E00</p>	<ul style="list-style-type: none"> <li>Nach Anlegen der Hilfsenergie bootet das Gerät.</li> <li>Nach erfolgreichem Bootvorgang wechselt die LCD-Anzeige in die Systemebene (links dargestellt).</li> </ul>

### 9.1.3 Feldbusadresse einstellen

**i** Die Feldbusadresse kann nur eingestellt werden, wenn sich das Gerät nicht im Zustand Data Exchange befindet.

Anzeige	Einstellungen
<pre>FBAdr  FB  I/O 120    OK  OK 12258E00</pre>	<ul style="list-style-type: none"> <li>• Ausgangsanzeige (links dargestellt)</li> </ul>
<pre>CPM      active 9440/15-01-11 12259E00</pre>	<ul style="list-style-type: none"> <li>• Tasten ▲ und ▼ gleichzeitig drücken. Es erscheint folgende Anzeige (links dargestellt).</li> </ul>
<pre>CPM      active FB addr : 5 12260E00</pre>	<ul style="list-style-type: none"> <li>• Tasten ▲ und ▼ gleichzeitig drücken. Es erscheint folgende Anzeige (links dargestellt).</li> </ul>
<pre>set FB address select: 5 12261E00</pre>	<ul style="list-style-type: none"> <li>• Tasten ▲ und ▼ gleichzeitig drücken. Es erscheint folgende Anzeige (links dargestellt).</li> </ul>
	<ul style="list-style-type: none"> <li>• Taste ▲ oder ▼ so lange drücken, bis gewünschte Feldbusadresse eingestellt ist. Beim Gedrückthalten der Taste wird der Wert schnell geändert. Der Einstellbereich geht von 0 ... 127.</li> </ul>
<pre>accept changes ? yes -&gt; CPM reset 12262E00</pre>	<ul style="list-style-type: none"> <li>• Tasten ▲ und ▼ gleichzeitig drücken. Es erscheint folgende Anzeige (links dargestellt).</li> </ul>
<pre>accept changes ? No 12263E00</pre>	<ul style="list-style-type: none"> <li>• Tasten ▲ und ▼ gleichzeitig drücken. Die Einstellungen werden übernommen. Das Gerät bootet erneut.</li> <li>oder</li> <li>• Tasten ▲ oder ▼ drücken. Es erscheint folgende Anzeige (links dargestellt).</li> </ul>
	<ul style="list-style-type: none"> <li>• Tasten ▲ und ▼ gleichzeitig drücken. Die Einstellung wird abgebrochen.</li> </ul>

**i** Nach dem Einstellen der Feldbusadresse bootet das Gerät erneut. Die Feldbusadresse ist permanent gespeichert und steht auch nach einem Reset oder einer Wiederinbetriebnahme zur Verfügung.

## 10 Betrieb

### 10.1 Betrieb

Nach Montage, Installation und Inbetriebnahme (siehe Kapitel "Montage und Installation" und "Parametrierung und Inbetriebnahme") ist das CPU & Power Modul betriebsbereit. Weiterführende Dokumentation beachten (Kopplungsbeschreibung).



Das CPM und die Sub-D-Stecker können während des Betriebs im explosionsgefährdeten Bereichen gefahrlos gesteckt oder gezogen werden (hot swap).

### 10.2 Anzeigen

Entsprechende LEDs am Gerät zeigen den Betriebszustand des Geräts an (siehe auch Kapitel "Funktion und Geräteaufbau").

LED	Farbe	Bedeutung
LED "RUN"	grün	Betriebsanzeige
LED "ERR"	rot	Anzeige Modulfehler

### 10.3 Fehlerbeseitigung

Bei der Fehlerbeseitigung folgenden Fehlersuchplan beachten:

Fehler	Fehlerursache	Fehlerbehebung
LED "RUN" leuchtet, LED "ERR" erloschen	CPM: OK Sammelalarm I/O-Signal	siehe LED-Anzeigen der I/O Module
LED "RUN" leuchtet, LED "ERR" blinkt	CPM: OK, I/O: Modul-Sammelalarm <ul style="list-style-type: none"> <li>• Module gestört</li> <li>• Modul nicht vorhanden</li> <li>• Falsches Modul gesteckt</li> </ul>	<ul style="list-style-type: none"> <li>• Modul tauschen</li> <li>• Modul stecken</li> <li>• Richtiges Modul stecken</li> </ul>
LED "RUN" blinkt, LED "ERR" erloschen	In Bereitschaft (nach dem Einschalten, aber noch ohne Datenaustausch mit dem Master)	<ul style="list-style-type: none"> <li>• Zyklischen Datenverkehr mit dem Master in Betrieb setzen.</li> <li>• Master und Busverbindung zu CPM prüfen.</li> </ul>
LED "RUN" blinkt, LED "ERR" blinkt	Data Exchange wurde verlassen (Ausgänge in Sicherheitsstellung). Zyklischer Datenverkehr mit dem Master ist unterbrochen.	<ul style="list-style-type: none"> <li>• Zyklischen Datenverkehr mit dem Master in Betrieb setzen.</li> <li>• Master und Busverbindung zu CPM prüfen.</li> </ul>
LED "RUN" blinkt, LED "ERR" leuchtet	Konfigurationsfehler. Konfiguration ist nicht in Ordnung	Konfiguration des Masters ändern.
LED "RUN" erloschen, LED "ERR" leuchtet/ blinkt	CPM-Hardwarefehler. <ul style="list-style-type: none"> <li>• Hardware-Check-Fehler</li> <li>• Eprom-Fehler</li> <li>• EEprom-Fehler</li> </ul>	CPM tauschen.
LED "RUN" erloschen, LED "ERR" erloschen	Keine Versorgungsspannung am CPM vorhanden oder CPM defekt.	<ul style="list-style-type: none"> <li>• Versorgung des CPM prüfen.</li> <li>• CPM prüfen.</li> <li>• BusRail prüfen.</li> <li>• CPM richtig auf BusRail aufrasten.</li> <li>• CPM tauschen.</li> </ul>

Wenn sich der Fehler mit den genannten Vorgehensweisen nicht beheben lässt:

- An R. STAHL Schaltgeräte GmbH wenden.

Zur schnellen Bearbeitung folgende Angaben bereithalten:

- Typ und Seriennummer des Geräts
- DCS/SPS
- Protokoll
- Revisions-Nr/Firmware-Version
- Kaufdaten
- Fehlerbeschreibung
- Einsatzzweck (insbesondere Eingangs-/Ausgangsbeschaltung)

## 11 Instandhaltung, Wartung, Reparatur

### 11.1 Instandhaltung

- Art und Umfang der Prüfungen den entsprechenden nationalen Vorschriften entnehmen.
- Prüfungsintervalle an Betriebsbedingungen anpassen.

Bei der Instandhaltung des Geräts mindestens folgende Punkte prüfen:

- fester Sitz der untergeklemmten Leitungen,
- Rissbildung und andere sichtbare Schäden am Gerätegehäuse und / oder Schutzgehäuse,
- Einhaltung der zulässigen Umgebungstemperaturen,
- Bestimmungsgemäße Funktion.

### 11.2 Wartung

Das Gerät benötigt keine regelmäßige Wartung.

	Die geltenden nationalen Bestimmungen im Einsatzland beachten.
---	--

### 11.3 Reparatur

	<b>GEFAHR</b>
	<p>Explosionsgefahr durch unsachgemäße Reparatur! Nichtbeachten führt zu schweren oder tödlichen Verletzungen.</p> <ul style="list-style-type: none"> <li>• Reparaturen an den Geräten ausschließlich durch R. STAHL Schaltgeräte GmbH ausführen lassen.</li> </ul>

## 11.4 Rücksendung

- Rücksendung bzw. Verpackung der Geräte nur in Absprache mit R. STAHL durchführen! Dazu mit der zuständigen Vertretung von R. STAHL Kontakt aufnehmen.

Für die Rücksendung im Reparatur- bzw. Servicefall steht der Kundenservice von R. STAHL zur Verfügung.

- Kundenservice persönlich kontaktieren.

oder

- Internetseite r-stahl.com aufrufen.
- Unter "Support" > "RMA Formular" > "RMA-Schein anfordern" wählen.
- Formular ausfüllen und absenden.  
Sie erhalten per E-Mail automatisch einen RMA-Schein zugeschickt.  
Bitte drucken Sie diese Datei aus.
- Gerät zusammen mit dem RMA-Schein in der Verpackung an die R. STAHL Schaltgeräte GmbH senden (Adresse siehe Kapitel 1.1).

## 12 Reinigung

- Zur Vermeidung elektrostatischer Aufladung dürfen die Geräte in explosionsgefährdeten Bereichen nur mit einem feuchten Tuch gereinigt werden.
- Bei feuchter Reinigung: Wasser oder milde, nicht scheuernde, nicht kratzende Reinigungsmittel verwenden.
- Keine aggressiven Reinigungsmittel oder Lösungsmittel verwenden.

## 13 Entsorgung

- Nationale und lokal gültige Vorschriften und gesetzliche Bestimmungen zur Entsorgung beachten.
- Materialien getrennt dem Recycling zuführen.
- Umweltgerechte Entsorgung aller Bauteile gemäß den gesetzlichen Bestimmungen sicherstellen.

## 14 Zubehör und Ersatzteile

### HINWEIS

Fehlfunktion oder Geräteschaden durch den Einsatz nicht originaler Bauteile.

Nichtbeachten kann Sachschaden verursachen!

- Nur Original-Zubehör und Original-Ersatzteile der R. STAHL Schaltgeräte GmbH verwenden.



Zubehör und Ersatzteile, siehe Datenblatt auf Homepage r-stahl.com.



## CPU & Power Module for Zone 1 / Div. 1

Series 9440/22, 9490



## Contents

1	General Information .....	3
1.1	Manufacturer .....	3
1.2	Information regarding the Operating Instructions .....	3
1.3	Further Documents .....	3
1.4	Conformity with Standards and Regulations .....	3
2	Explanation of the Symbols .....	4
2.1	Symbols in these Operating Instructions .....	4
2.2	Warning Notes .....	4
2.3	Symbols on the Device .....	5
3	Safety Notes .....	5
3.1	Operating Instructions Storage .....	5
3.2	Personnel Qualification .....	5
3.3	Safe Use .....	6
3.4	Modifications and Alterations .....	7
4	Function and Device Design .....	7
4.1	Function .....	8
4.2	Device Design .....	8
5	Technical Data .....	9
6	Engineering .....	14
6.1	Auxiliary Power Connection Assignment .....	15
6.2	X1, X2, X3 Sub-D Socket Terminal Assignment .....	15
7	Transport and Storage .....	15
8	Mounting and Installation .....	16
8.1	Dimensions / Fastening Dimensions .....	17
8.2	Mounting / Dismounting, Operating Position .....	18
8.3	Installation .....	20
9	Parameterization and Commissioning .....	21
9.1	Parameterizations .....	21
10	Operation .....	27
10.1	Operation .....	27
10.2	Indications .....	27
10.3	Troubleshooting .....	28
11	Maintenance, Overhaul, Repair .....	29
11.1	Maintenance .....	29
11.2	Overhaul .....	29
11.3	Repair .....	29
11.4	Returning the Device .....	30
12	Cleaning .....	30
13	Disposal .....	30
14	Accessories and Spare Parts .....	30



# 1 General Information

## 1.1 Manufacturer

R. STAHL Schaltgeräte GmbH  
Am Bahnhof 30  
74638 Waldenburg  
Germany

Phone: +49 7942 943-0  
Fax: +49 7942 943-4333  
Internet: r-stahl.com  
E-Mail: info@r-stahl.com

## 1.2 Information regarding the Operating Instructions

ID-No.: 162277 / 9440607310  
Publication Code: 2021-10-12-BA00-III-en-08

The original instructions are the English edition.  
They are legally binding in all legal affairs.

## 1.3 Further Documents

- IS1+ coupling description (download from r-stahl.com)
- Data sheet

For documents in other languages, see r-stahl.com.

## 1.4 Conformity with Standards and Regulations

See certificates and EU Declaration of Conformity: r-stahl.com.

The device has IECEx approval. For certificate please refer to the IECEx homepage:  
<http://iecex.iec.ch/>

Further national certificates can be downloaded via the following link:  
<https://r-stahl.com/en/global/support/downloads/>.

## 2 Explanation of the Symbols

### 2.1 Symbols in these Operating Instructions

Symbol	Meaning
	Tips and recommendations on the use of the device
	Danger due to explosive atmosphere
	Danger due to live components



### 2.2 Warning Notes

Warnings must be observed under all circumstances, in order to minimize the risk due to construction and operation. The warning notes have the following structure:

- Signalling word: DANGER, WARNING, CAUTION, NOTICE
- Type and source of danger/damage
- Consequences of danger
- Taking countermeasures to avoid the danger or damage

	<b>DANGER</b>
	Danger to persons Non-compliance with the instruction results in severe or fatal injuries to persons.
	<b>WARNING</b>
	Danger to persons Non-compliance with the instruction can result in severe or fatal injuries to persons.
	<b>CAUTION</b>
	Danger to persons Non-compliance with the instruction can result in light injuries to persons.
<b>NOTICE</b>	
Avoiding material damage Non-compliance with the instruction can result in material damage to the device and / or its environment.	

## 2.3 Symbols on the Device

Symbol	Meaning
 0158 <small>05594E00</small>	CE marking according to the current applicable directive.
 02198E00	Electric circuit certified for hazardous areas according to the marking.
 11048E00	Safety instructions that must always be followed: The respective data must be noted and/or the safety-related instructions contained in the operating instructions must be followed for devices with this symbol!

## 3 Safety Notes

### 3.1 Operating Instructions Storage

- Read the operating instructions carefully.
- Store the operating instructions at the mounting location of the device.
- Observe applicable documents and operating instructions of the devices to be connected.

### 3.2 Personnel Qualification

Qualified specialist personnel are required to perform the tasks described in these operating instructions. This primarily applies to work in the following areas

- Project engineering
- Mounting/dismounting the device
- (Electrical) Installation
- Commissioning
- Maintenance, repair, cleaning

Specialists who perform these tasks must have a level of knowledge that meets applicable national standards and regulations.

Additional knowledge is required for tasks in hazardous areas! R. STAHL recommends having a level of knowledge equal to that described in the following standards:

- IEC/EN 60079-14 (Electrical installations design, selection and construction)
- IEC/EN 60079-17 (Inspection and maintenance of electrical installations)
- IEC/EN 60079-19 (Equipment repair, overhaul and reclamation)

### 3.3 Safe Use

#### Before mounting

- Read and observe the safety notes in these operating instructions!
- Ensure that the contents of these operating instructions are fully understood by the personnel in charge.
- Use the device in accordance with its intended and approved purpose only.
- Always consult with R. STAHL Schaltgeräte GmbH if using the device under operating conditions which are not covered by the technical data.
- Make sure that the device is not damaged.
- We cannot be held liable for damage at the device caused by incorrect or unauthorised use or non-compliance with these operating instructions.



#### For mounting and installation

- Have mounting and installation performed only by qualified and authorised persons (see chapter "Qualification of the personnel").
- The device is only to be installed in areas for which it is suited based on its marking.
- During installation and operation, observe the information (characteristic values and rated operating conditions) on the rating, data and information plates located on the device.
- Before installation, make sure that the device is not damaged.
- Electrical circuits with the "Ex i" type of protection can no longer be operated as circuits with this protection type after being operated with circuits with other types of protection.
- When used in Zone 1, the device is to be installed in a protective enclosure or in a cabinet according to IEC/EN 60079-7 and IEC/EN 60079-31. This enclosure (or cabinet) has a suitable degree of protection (at least IP54).
- When used in Zone 2, the device is to be installed in a protective enclosure or in a cabinet according to IEC/EN 60079-15. This enclosure (or cabinet) has a suitable degree of protection (at least IP54).
- When used in Zone 21 or 22, the device is to be installed in a protective enclosure or in a cabinet according to IEC/EN 60079-31. This enclosure (or cabinet) has a suitable degree of protection (at least IP64).
- If installation is performed according to NEC, the Control drawing must be observed!
- Separate intrinsically safe and non-intrinsically safe circuits from each other (see EN/IEC 60079-14), e.g. in different cable ducts.
- A minimum distance or tight string length of 50 mm, ideally around an insulating or earthed metal isolating plate, must be provided between the connection points of intrinsically-safe and non-intrinsically safe circuits.
- Insulate unused conductors at the socket with an unconnected cable end, e.g. by connecting to an Ex e terminal.
- Connect only one, permitted auxiliary power per socket. Look up the corresponding required specific data about the connections in the "Technical data" chapter.
- Ensure degree of protection IP30 at the Ex e terminal.
- Secure unoccupied connection terminals using protection against accidental contact.
- Connect only conductors with a maximum cross section of 2.5 mm<sup>2</sup>.
- Galvanically isolate all devices connected to RS485 interfaces from each other and from all electric circuits.

**Commissioning, maintenance, repair**

- Only have commissioning and repairs performed by qualified and authorised persons (see chapter "Personnel qualification").
- Before commissioning, make sure that the device is not damaged.
- Perform only maintenance work described in these operating instructions.
- Always clean the device with a damp cloth to prevent electrostatic charge.

**3.4 Modifications and Alterations**

	<b>DANGER</b>
	<p>Explosion hazard due to modifications and alterations to the device! Non-compliance results in severe or fatal injuries.</p> <ul style="list-style-type: none"> <li>• Do not modify or alter the device.</li> </ul>
	<p>No liability or warranty for damage resulting from modifications and alterations.</p>

**4 Function and Device Design**

	<b>DANGER</b>
	<p>Explosion hazard due to improper use! Non-compliance results in severe or fatal injuries.</p> <ul style="list-style-type: none"> <li>• Use the device only in accordance with the operating conditions described in these operating instructions.</li> <li>• Use the device only for the intended purpose specified in these operating instructions.</li> </ul>

## 4.1 Function

The CPU & power module (CPM) 9440/22 fulfils the function of a gateway between the internal bus of an IS1+ field station and the fieldbus which connects the field station singly or redundantly to the automation system.

### Application range

The CPM is designed for IS 1+ field stations and may be installed in hazardous areas of Zone 1 / Division 1, Zone 2 / Division 2 or Zone 21 and 22 and in safe areas.

### Mode of operation

The CPM contains a power supply unit for its own power supply and also for supply to the I/O modules and field circuits. The power supply unit is fitted with undervoltage monitoring. The power supply for the I/O modules is implemented via the BusRail. Communication with the I/O modules is implemented via the address and data lines on the BusRail. The interface of the CPU & power module with the internal data bus on the BusRail is designed with redundancy.

## 4.2 Device Design

	#	Device component	Description
	1	Cover flap	Cover flap to ensure degree of protection IP30 (opened)
	2	Terminal	Ex e terminal (only for socket 9490/11-12)
	3	Notch lever	Notch lever for removing the module from the socket
	4	Socket	Socket for the module
	5	Clamping screw	Clamping screw for DIN rail
	6	Socket	Socket for the module
	7	Notch lever	Notch lever for removing the module from the socket
	8	LCD display	LCD display
	9	LED	LED for status or error indication (see the "Troubleshooting" chapter for further information)
	10	Buttons	Buttons <up>, <down>
	11	X1 Sub-D socket	Process bus, primary
	12	X2 Sub-D socket	Process bus, redundant (can only be used with PROFIBUS DP!)
	13	X3 Sub-D socket	ServiceBus
	14	Unconnected cable end	only for socket 9490/13-12
		Conduit hub	only for socket 9490/12-12
15	CPU & power module	CPU & power module	

## 5 Technical Data

### Explosion Protection

#### Global (IECEX)

Gas	IECEX KEM 08.0038X
9440/22-01-.1:	Ex db [ia Ga] [ib Gb] IIC T4 Gb
9490/11-12:	Ex db eb [ia Ga] [ib Gb] IIC T4 Gb
9490/13-12:	Ex db mb [ia Ga] [ib Gb] IIC T4 Gb

#### Europe (ATEX)

Gas	KEMA 02 ATEX 1333 X
9440/22-01-.1:	⊕ II 2 G Ex db [ia Ga] [ib Gb] IIC T4 Gb
9490/11-12:	⊕ II 2 G Ex db eb [ia Ga] [ib Gb] IIC T4 Gb
9490/13-12:	⊕ II 2 G Ex db mb [ia ga] [ib gb] IIC T4 Gb

#### Certifications and certificates

Certificates	IECEX, ATEX, EAC (TR), Brazil (INMETRO), India (PESO), Canada (FM), USA (FM)
Ship approval	EU RO Mutual Recognition (incl. ABS, BV, CCS, CRS, DNV GL, IRS, KR, LR, ClassNK, PRS, RINA, RS)

#### Further parameters

Further information	see respective certificate and operating instructions
---------------------	---

#### Safety data

Max. output voltage	$U_{out} = 26.2 \text{ V}$ to supply the I/O modules
Connection to intrinsically safe RS485-IS fieldbus	Global (IECEX): IECEX PTB 11.0027, Ex ib IIC T4 Gb Europe (ATEX): PTB 04 ATEX 2089, ⊕ II 2 G Ex ib IIC T4 Gb
Maximum values for fieldbus and ServiceBus (RS485-IS)	
Max. voltage $U_o$	3.7 V
Max. voltage $U_i$	+/- 4.2 V
Max. current $I_o$	134 mA
Max. power $P_o$	124 mW
Max. capacitance $C_o$ for IIC	1000 $\mu\text{F}$
Max. inductance $L_o$ for IIC	1.9 mH

**Technical Data**

Version	9440/22-01-11 (24 V DC)	9440/22-01-21 (90 to 253 V AC)
<b>Electrical data</b>		
Auxiliary power		
Nominal voltage	24 V DC	120 V/230 V AC
Voltage range	20 to 35 V DC	90 to 253 V AC
Mains frequency	–	50/60 Hz
Frequency range	–	45 to 66 Hz
Current consumption		
without I/O modules	approx. 0.21 A at 24 V DC	approx. 25 mA at 230 V AC, approx. 48 mA at 120 V AC
with 8 I/O modules	approx. 2.5 A at 24 V DC	approx. 0.4 A at 230 V AC, approx. 0.8 A at 120 V AC
Power dissipation		
without I/O modules	5 W	8.4 W
Per I/O module	approx. 1.4 W	approx. 1 W
Polarity reversal protection	yes	not applicable
Undervoltage monitoring	yes	yes
Interfaces for fieldbus, redundant fieldbus and ServiceBus		
Interface	RS485-IS acc. to Profibus specification	
Cable length / Transfer rate		
Copper cable	1200 m with 9.6 to 93.75 kbit/s 1000 m with 187.5 kbit/s 400 m with 500 kbit/s 200 m with 1.5 Mbit/s	
Fibre optic cable	approx. 2000 m with 1.5 Mbit/s	
ServiceBus	1200 m with 9.6 kbit/s	
Line termination	powered resistor (termination resistor is installed in the Sub-D plug, see accessories)	
Address range	0 to 127	
Redundancy	System redundancy	



**Technical Data**

<b>Profibus</b>	
Versions	DP V0, DP V1, DP V1 HART
Transfer rate	9.6 kbit/s to 1.5 Mbit/s
Data transmission	approx. 40 16-bit words / ms (cyclic, net at 1.5 Mbit/s)
<b>Modbus RTU</b>	
Transfer rate	9.6 to 38.4 kbit/s
Data transmission	Approx. 1000 16-bit register/s (at 38.4 kbit/s)
Functions	Read, Write; see Modbus RTU coupling instructions
<b>Characteristic values</b>	
Max. internal signal delay for 8 I/O modules (without I/O module delay)	
For digital modules	7 ms
For analogue modules	10 ms
<b>Operator interface</b>	
Software	IS1+ DTM devices or IS Wizard
Operation	"RUN" LED, green
Fault	"ERR" LED, red
LCD indication	2 x 16 characters
Settings	bus address
Indications	Bus addresses, alarms / faults, information (type, revision, etc.) for the levels: field station, modules and signals, values of the inputs and outputs
<b>Diagnostic and parameterisation</b>	
Functions	<ul style="list-style-type: none"> <li>• Load or read back configuration data and parameters in IS1+ field stations</li> <li>• Read inputs</li> <li>• Read and write outputs</li> <li>• Transmit diagnostics data (e.g. configuration error, hardware error, signal error)</li> <li>• Transmit HART commands from/to HART field devices</li> </ul>
Connectable software packages	<ul style="list-style-type: none"> <li>• IS Wizard (via R. STAHL ServiceBus)</li> <li>• R. STAHL DTM</li> <li>• AMS by Emerson Process Management</li> <li>• PDM by Siemens</li> <li>• PRM and Fieldmate by Yokogawa</li> <li>• FieldCare by Endress + Hauser</li> <li>• FDM by Honeywell</li> <li>• etc.</li> </ul>

**Technical Data**

Power supply for the I/O modules via the BusRail	
Voltage range	22.5 to 26.2 V DC
Max. current	2 A
Max. number of I/O modules	8
Redundant supply for the I/O modules	yes (decoupled with diodes)
Undervoltage monitoring	yes
Galvanic separation	
between power supply and system components	1500 V AC
between Fieldbus/ServiceBus interface and system components	500 V AC
between two bus interfaces	500 V AC
Electromagnetic compatibility	Tested to the following standards and regulations: EN 61326-1, EN 61000-4-1 to 6, NAMUR NE 21

**Ambient conditions**

Ambient temperature	-20 to +65 °C
Storage temperature	-40 to +70 °C
Maximum relative humidity	95 % (no condensation)
Use at the height of	< 2,000 m
Semi-sinusoidal shock (IEC/EN 60068-2-27)	15 g (3 shocks per axis and direction)
Sinusoidal vibration (IEC/EN 60068-2-6)	1 g in frequency range between 10 to 500 Hz 2 g in frequency range between 45 to 100 Hz

**Technical Data**

**Mechanical data**

Connection		
Fieldbus RS485	Sub-D socket 9-pin	
ServiceBus RS485	Sub-D socket 9-pin	
Power supply	Socket 9490/11-12	Ex e terminals 4.0 mm <sup>2</sup>
	Socket 9490/13-12	Unconnected cable end, 5 m, 1 mm <sup>2</sup> per core
	Socket 9490/12-12	Conduit
Degree of protection (IEC 60529)		
Modules	IP30	
Connections	IP20	
Module enclosure	Polyamide 6GF	
Fire resistance (UL 94)	HB	

**Mounting / Installation**

Installation conditions	
Mounting type	on 35 mm DIN rail NS 35/15
Mounting orientation	horizontal and vertical

For further technical data, see [r-stahl.com](http://r-stahl.com).

## 6 Engineering

### NOTICE

Failure of the devices installed in the cabinet caused by too high ambient temperature!

Non-compliance can result in material damage.

- Install and adjust the cabinet in such a way that it is always operated within the permissible temperature range.
- Carefully observe the "Cabinet installation guide".

The following conditions must be ensured during project engineering:

- Install the device for intended use on the IS1+ BusRail.
- Operate up to 8 I/O modules on the device.
- Operation of the device is only permissible in three mounting positions (see also the "Mounting/dismounting on BusRail" chapter).
- Mount the primary device on the first slot of the BusRail.
- Mount the redundant device (optional) on the second slot of the BusRail.
- Connect the DIN rail of the BusRail to the equipotential bonding of the hazardous area.
- Work on the connected auxiliary power electrical circuits only if they are de-energised.
- For use in hazardous areas, suitable fieldbus isolating repeaters (e.g. R. STAHL 9185 or 9186 series) must be used between the fieldbus connections (X1, X2, X3) and the automation system. This also applies if the CPU & power module is installed in the safe area but fieldbus electrical circuits from the connected I/O modules lead into the hazardous area.

## 6.1 Auxiliary Power Connection Assignment

For the auxiliary power connection there are 3 different sockets available:

- 9490/11-12: Connection by means of Ex e terminal
- 9490/13-12: Connection by means of an unconnected cable end
- 9490/12-12: Connection by means of conduit

Ex e terminal Terminal no.	Unconnected cable end Conductor no.	Function
1	1	+24 V DC
2	2	0 V
4	2	N (90 to 253 V AC)
6	3	L (90 to 253 V AC)
3, 5, 7, 8, 9, 10, 11, 12, 13, 14, 15, 16	–	Do not connect any electrical lines

## 6.2 X1, X2, X3 Sub-D Socket Terminal Assignment

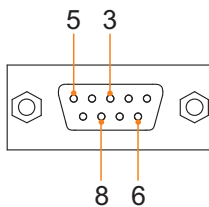

12224E00

Pin no.	Function	Description
3	RxD/TxD (+)	Data B (+)
5	GND	Reference potential for device interface
6	PWR (+)	Supply voltage (device)
8	RxD/TxD (-)	Data A (-)
Remaining pins	–	Not connected

## 7 Transport and Storage

- Transport and store the device only in the original packaging.
- Store the device in a dry place (no condensation) and vibration-free.
- Do not drop the device.

## 8 Mounting and Installation

The device is approved for use in gas explosion hazardous areas of Zone 1/Division 1 and Zone 2/Division 2, in dust explosion hazardous areas of Zones 21 and 22 and in safe areas.

	DANGER
	<p>Explosion hazard due to incorrect installation of the device! Non-compliance results in severe or fatal injuries.</p> <ul style="list-style-type: none"> <li>• Carry out installation strictly according to the instructions and national safety and accident prevention regulations to maintain the explosion protection.</li> <li>• Select and install the electrical device so that explosion protection is not affected due to external influences, i.e. pressure conditions, chemical, mechanical, thermal and electric impact such as vibration, humidity and corrosion (see IEC/EN 60079-14).</li> <li>• The device must only be installed by trained qualified personnel who is familiar with the relevant standards.</li> </ul>

## 8.1 Dimensions / Fastening Dimensions

Dimensional drawings (all dimensions in mm [inches]) – Subject to alterations

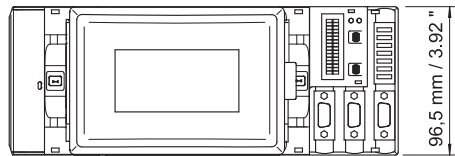
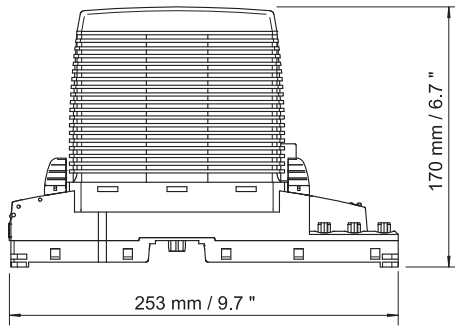

**9490/11-12**  
CPU & power module for Zone 1  
with connection by means of Ex e terminals

09877E00

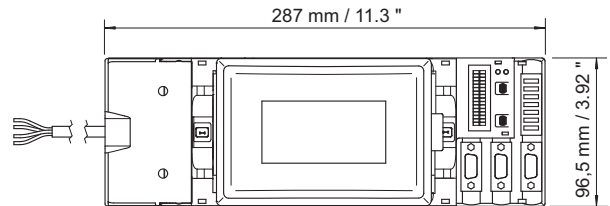
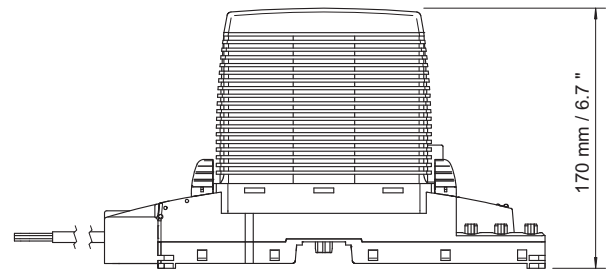

**9490/12-12 only FM**  
CPU & power module for Division 1  
with connection by means of a conduit

07762E00

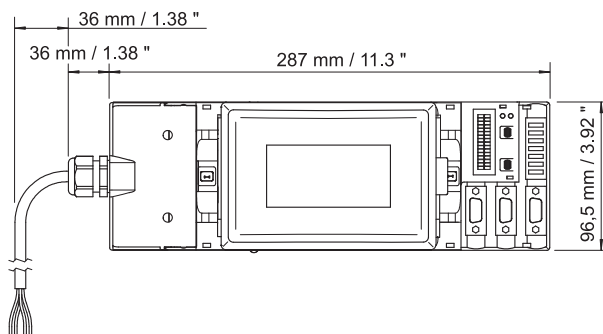
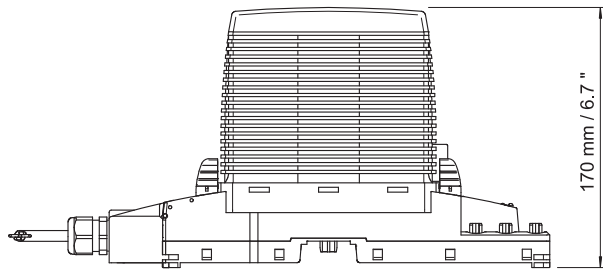

**9490/13-12**  
CPU & power module for Zone 1  
with connection by means of an unconnected cable  
end

07760E00

## 8.2 Mounting / Dismounting, Operating Position

### 8.2.1 Mounting / Dismounting on BusRail

#### NOTICE

Malfunction or device damage caused by improper mounting.

Non-compliance may lead to material damage!

- Mount the device in vertical direction only, with the reading direction of the LCD display from below, left or right, as desired.

#### Mounting the socket on BusRail

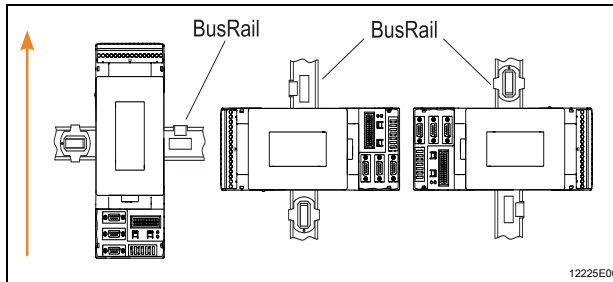

- Position the socket vertically onto the first slot of the BusRail.
- Snap the socket into place by slightly pressing it.

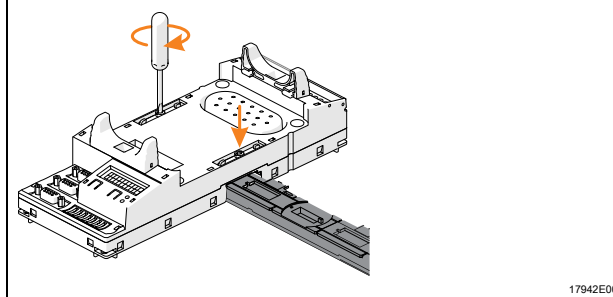

- Fasten the socket to the DIN rail using the clamping screws (tightening torque 0.5 to 0.6 mm).

#### Mounting / inserting the CPM module on / into the socket

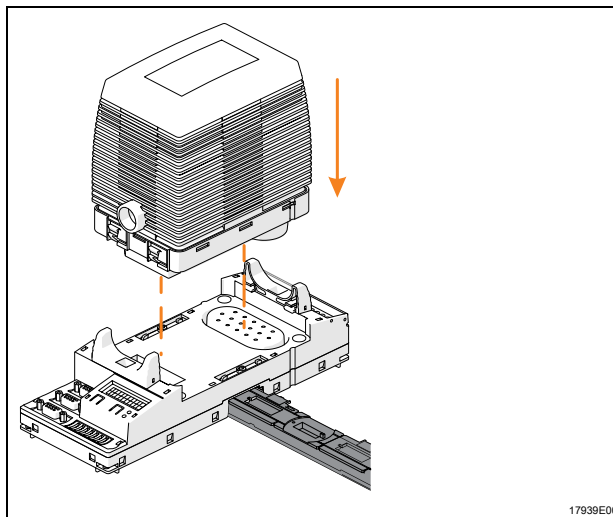

- Position the CPM vertically on the socket, aligning the connectors on the module with the sockets of the socket as you do so.
- Snap the CPM into place by pressing it.
- Make sure the CPM has snapped into place on both sides by pressing down the CPM again at the back and at the front.



## 8.2.2 Dismounting / Replacement of the Module

	<b>WARNING</b>
	<p>Risk of electric shock due to live terminal! Non-compliance can result in severe injuries and material damage.</p> <ul style="list-style-type: none"> <li>• Work on the Ex e terminals or unconnected cable end only if de-energised.</li> </ul>

## Replacing the CPM module

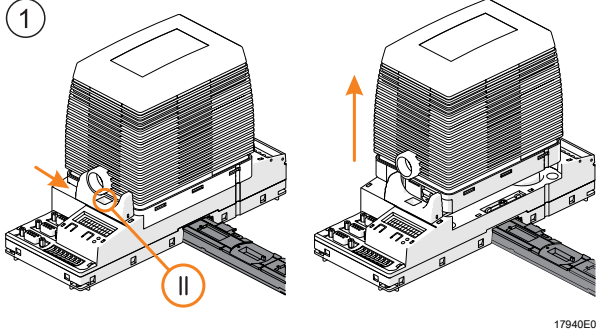
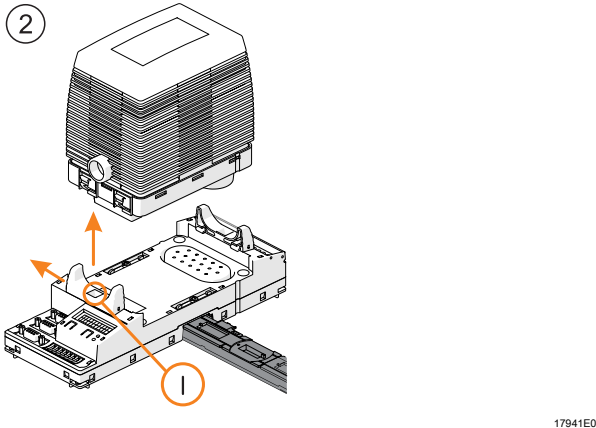
 <p style="text-align: right; font-size: small;">17940E00</p>	<ul style="list-style-type: none"> <li>• Push both notch levers into position "II", figure 1.</li> <li>• Vertically pull out the module from the socket to the stop.</li> <li>• Push both notch levers into position "I", figure 2.</li> <li>• Remove the module from the socket vertically.</li> <li>• Position a new module vertically onto the socket.</li> <li>• Snap the module into place by pressing it.</li> <li>• Make sure the CPM has snapped into place on both sides by pressing down the CPM again at the back and at the front.</li> </ul>
 <p style="text-align: right; font-size: small;">17941E00</p>	

### Replacing the socket

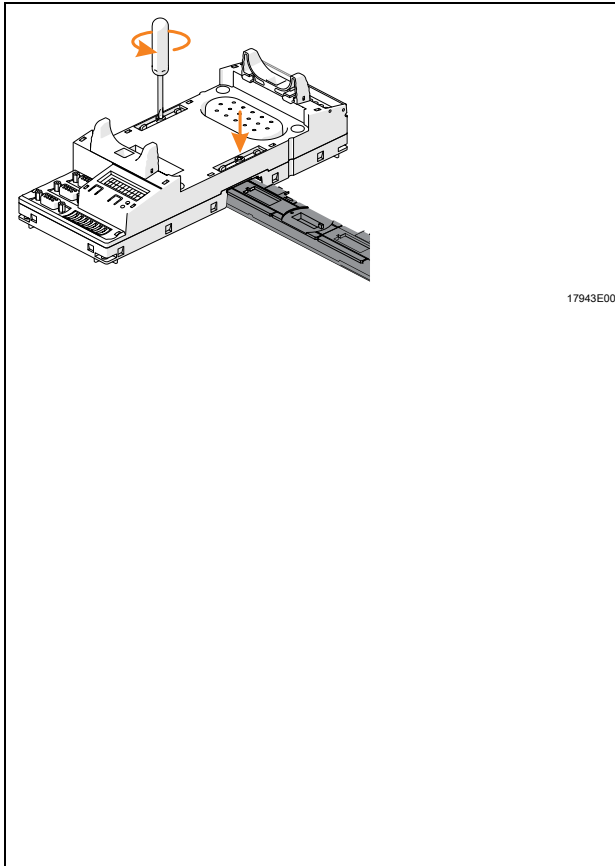

- Remove the CPM, see the "Replacing the CPM module" chapter.
- Remove the auxiliary power from the Ex e terminal or disconnect the unconnected cable end from the auxiliary power.
- Remove the fieldbus connections from the Sub-D sockets.
- Loosen the clamping screws of the socket.
- Remove the socket vertically from the BusRail.
- Install a new socket vertically on the BusRail, see also the "Mounting the socket on BusRail" chapter.
- Insert a new CPM module into the socket, see also the "Mounting / inserting the CPM module on / into the socket" chapter.
- Connect the fieldbuses again to the Sub-D sockets.
- Reconnect the auxiliary power.

## 8.3 Installation

	<p>Operation under difficult conditions, such as, in particular, on ships, requires additional measures to be taken for correct installation, depending on the place of use. Further information and instructions on this can be obtained from your regional sales contact on request.</p>
--	--

### 8.3.1 Connection of the Auxiliary Power

For the auxiliary power there are three different sockets available:

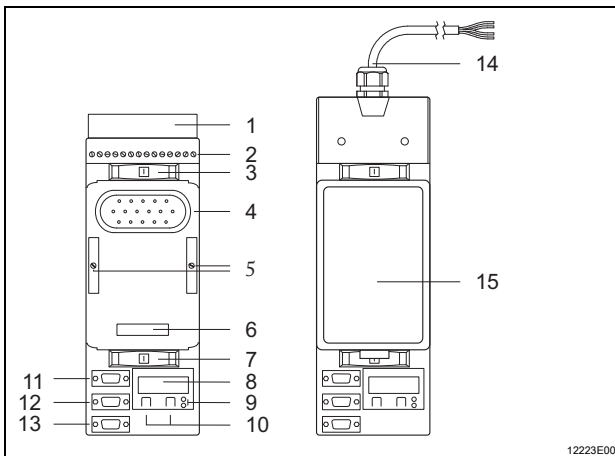

- 9490/11-12: Connection by means of Ex e terminals (2)
- 9490/13-12: Connection by means of an unconnected cable end (14)
- 9490/12-12: Connection by means of a conduit (14)



- Only auxiliary power 20 to 35 V DC for the CPM 9440/22-01-11 or 90 to 230 V AC for the CPM 9440/22-01-21 may be connected to the socket. Simultaneous connection of both auxiliary power sources is not permitted.
- Unused conductors at the socket with an unconnected cable end must be insulated (e.g. by connecting to an Ex e terminal).

### 8.3.2 Connecting the Fieldbus

- Connect the primary fieldbus to the Sub-D socket X1.
- If necessary, connect a redundant fieldbus to Sub-D socket X2 (only possible with Profibus DP!).
- Secure the Sub-D connector against loosening using screws (tightening torque 0.5 to 0.6 Nm).

### 8.3.3 Connecting the ServiceBus

- Connect the ServiceBus to Sub-D socket X3.
- Secure the Sub-D connector against loosening using screws (tightening torque 0.5 to 0.6 Nm).

## 9 Parameterization and Commissioning



### DANGER

Explosion hazard due to incorrect installation!

Non-compliance results in severe or fatal injuries.

- Check the device for proper installation before commissioning.
- Comply with national regulations.

Before commissioning, ensure the following:

- Installation of the device according to regulations.
- Correct connection of the cables.
- No damage at the device and connection cables.
- Tight seat of the screws at the terminals.  
Correct tightening torque: 0.5 to 0.6 Nm.

### 9.1 Parameterizations

Parameterisation and commissioning of the CPM and of the connected I/O modules is carried out using the automation system and the ServiceBus (optional).

Only the fieldbus address of the CPM must be set directly at the socket.

The buttons of the LCD display in the socket can be used

- to set the fieldbus address of the device
- Display information about the device and the I/O modules installed on the BusRail (see "Display" chapter).

## 9.1.1 LCD Displays

## Switch to a specific module display

LCD display	Settings
<div style="border: 1px solid black; padding: 5px; width: fit-content;">                     FBAdr FB I/O                      120 OK OK                 </div> <p style="text-align: right; font-size: small;">12258E00</p>	<ul style="list-style-type: none"> <li>Initial display (shown on the left)</li> </ul>
<div style="border: 1px solid black; padding: 5px; width: fit-content;">                     CPM active                      9440/15-01-11                 </div> <p style="text-align: right; font-size: small;">12259E00</p>	<ul style="list-style-type: none"> <li>Press the ▲ and ▼ buttons simultaneously to switch from the system level to the module level. The following display appears (shown on the left).</li> <li>Select the desired module by pressing the ▲ or ▼ button.</li> </ul>
	<ul style="list-style-type: none"> <li>Press the ▲ and ▼ buttons simultaneously. The display switches to the information level.</li> <li>Press the ▲ or ▼ button to switch between different LCD displays (see following table).</li> </ul>

## Display of the CPM status information

LCD display	Display/function																				
<div style="border: 1px solid black; padding: 5px; width: fit-content;">                     CPM active                      FB addr : 5                 </div> <p style="text-align: right; font-size: small;">12260E00</p>	Status and fieldbus address of the device.																				
<div style="border: 1px solid black; padding: 5px; width: fit-content;">                     CPM information                      Modbus V10-00                 </div> <p style="text-align: right; font-size: small;">12264E00</p>	Type of coupling																				
<div style="border: 1px solid black; padding: 5px; width: fit-content;">                     CPM status                      config/para fail                 </div> <p style="text-align: right; font-size: small;">12265E00</p>	Status of the device.  Possible status information: <table border="1" style="width: 100%; border-collapse: collapse;"> <thead> <tr> <th>Status information on the LCD display</th> <th>Meaning</th> </tr> </thead> <tbody> <tr> <td>No error</td> <td>No error</td> </tr> <tr> <td>Hardware fail (1)</td> <td>Hardware error detected</td> </tr> <tr> <td>Hardware fail (2)</td> <td>Wrong hardware identification</td> </tr> <tr> <td>Hardware fail (3)</td> <td>No communication between CPR and IOP</td> </tr> <tr> <td>DataExch AS</td> <td>Data Exchange with automation system, configuration via Profibus</td> </tr> <tr> <td>DataExch AS (2)</td> <td>Data Exchange with automation system</td> </tr> <tr> <td>No DataExch</td> <td>No data exchange</td> </tr> <tr> <td>Config/para fail</td> <td>Configuration or parameter error</td> </tr> <tr> <td>Quit DataExch</td> <td>No more data exchange</td> </tr> </tbody> </table>	Status information on the LCD display	Meaning	No error	No error	Hardware fail (1)	Hardware error detected	Hardware fail (2)	Wrong hardware identification	Hardware fail (3)	No communication between CPR and IOP	DataExch AS	Data Exchange with automation system, configuration via Profibus	DataExch AS (2)	Data Exchange with automation system	No DataExch	No data exchange	Config/para fail	Configuration or parameter error	Quit DataExch	No more data exchange
Status information on the LCD display	Meaning																				
No error	No error																				
Hardware fail (1)	Hardware error detected																				
Hardware fail (2)	Wrong hardware identification																				
Hardware fail (3)	No communication between CPR and IOP																				
DataExch AS	Data Exchange with automation system, configuration via Profibus																				
DataExch AS (2)	Data Exchange with automation system																				
No DataExch	No data exchange																				
Config/para fail	Configuration or parameter error																				
Quit DataExch	No more data exchange																				
<div style="border: 1px solid black; padding: 5px; width: fit-content;">                     CPM active                      back                 </div> <p style="text-align: right; font-size: small;">12266E00</p>	Press the ▲ and ▼ buttons simultaneously. To switch back to module level of the device.																				
<div style="border: 1px solid black; padding: 5px; width: fit-content;">                     CPM active                      exit menu                 </div> <p style="text-align: right; font-size: small;">12267E00</p>	Press the ▲ and ▼ buttons simultaneously. To switch back to main display of the device.																				

### Switch to a specific module display

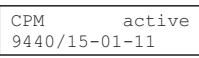
LCD display	Settings
 <p style="text-align: right; font-size: small;">12258E00</p>	<ul style="list-style-type: none"> <li>Initial display (shown on the left)</li> </ul>
 <p style="text-align: right; font-size: small;">12259E00</p>	<ul style="list-style-type: none"> <li>Press the ▲ and ▼ buttons to switch from the system level to the module level. The following display appears (shown on the left).</li> <li>Select the desired module by pressing the ▲ or ▼ button.</li> </ul>
	<ul style="list-style-type: none"> <li>Press the ▲ and ▼ buttons simultaneously. The display switches to the information level/service level.</li> </ul>

### Status information display for the I/O module

	<p>The following displays show the same design for all I/O modules.</p>
---	---

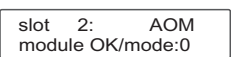
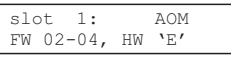
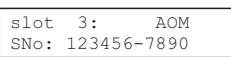
LCD display	Display/function																								
 <p style="text-align: right; font-size: small;">12268E00</p>	<p>Display of the slot, module type and module status.</p> <p>Possible module statuses:</p> <table border="1" style="width: 100%; border-collapse: collapse;"> <thead> <tr> <th>Status information on the LCD display</th> <th>Meaning</th> <th>Prio</th> </tr> </thead> <tbody> <tr> <td>IOM no response</td> <td>Communication with the module is not possible. The module is defective or not connected, or both BusRails and/or the BusRail connecting cable are damaged</td> <td style="text-align: center;">1</td> </tr> <tr> <td>Hardware failure</td> <td>The module reports a hardware fault</td> <td style="text-align: center;">2</td> </tr> <tr> <td>conf unequal mod</td> <td>Configuration error or the wrong module was plugged in</td> <td style="text-align: center;">3</td> </tr> <tr> <td>HW disable outp.</td> <td>Outputs disconnected by an external switch (Plant-Stop) (only with DOM 9475/2)</td> <td style="text-align: center;">4</td> </tr> <tr> <td>prim. Rail fail</td> <td>No communication via primary BusRail data bus</td> <td style="text-align: center;">5</td> </tr> <tr> <td>red. Rail fail</td> <td>No communication via redundant BusRail data bus</td> <td style="text-align: center;">5</td> </tr> <tr> <td>module OK/mode: x</td> <td>Module is OK. No module error. Signal errors are still possible. The configured operating mode (mode:x) is also displayed</td> <td style="text-align: center;">6</td> </tr> </tbody> </table> <p>In case of several faults, only the fault with the highest priority is displayed. After eliminating this fault, the fault with the next highest priority is displayed.</p>	Status information on the LCD display	Meaning	Prio	IOM no response	Communication with the module is not possible. The module is defective or not connected, or both BusRails and/or the BusRail connecting cable are damaged	1	Hardware failure	The module reports a hardware fault	2	conf unequal mod	Configuration error or the wrong module was plugged in	3	HW disable outp.	Outputs disconnected by an external switch (Plant-Stop) (only with DOM 9475/2)	4	prim. Rail fail	No communication via primary BusRail data bus	5	red. Rail fail	No communication via redundant BusRail data bus	5	module OK/mode: x	Module is OK. No module error. Signal errors are still possible. The configured operating mode (mode:x) is also displayed	6
Status information on the LCD display	Meaning	Prio																							
IOM no response	Communication with the module is not possible. The module is defective or not connected, or both BusRails and/or the BusRail connecting cable are damaged	1																							
Hardware failure	The module reports a hardware fault	2																							
conf unequal mod	Configuration error or the wrong module was plugged in	3																							
HW disable outp.	Outputs disconnected by an external switch (Plant-Stop) (only with DOM 9475/2)	4																							
prim. Rail fail	No communication via primary BusRail data bus	5																							
red. Rail fail	No communication via redundant BusRail data bus	5																							
module OK/mode: x	Module is OK. No module error. Signal errors are still possible. The configured operating mode (mode:x) is also displayed	6																							
 <p style="text-align: right; font-size: small;">12269E00</p>	<p>Display of the firmware and hardware revision.</p>																								
 <p style="text-align: right; font-size: small;">12270E00</p>	<p>Display of the serial number.</p>																								

## Digital module

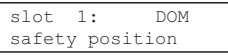
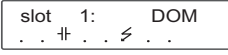
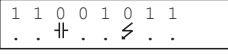
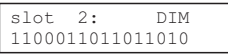
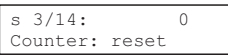
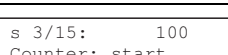

In addition to the general displays, digital modules also exhibit the following displays:

LCD display	Display/function
 12272E00	In the absence of output data, the safety status of the outputs is displayed. (for output module only)
 12273E00	I/O error. † : wire breakage ≲ : short circuit
 12274E00	I/O data and error.
 12276E00	I/O data. The value for channel 0 is displayed on the left, for channel 15 on the right.
 12279E00	Display of the counter value/frequency value and of the "start" and "reset" control bits for channel 14. (for input module only)
 12280E00	Display of the counter value/frequency value and of the "start" and "reset" control bits for channel 15. (for input module only)

## Analogue module

In addition to the general displays, the analogue module also has the following displays, see table.

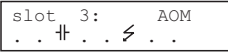
When using HART for module 9468, there are additional menu items (see "Analogue module with HART")

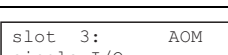
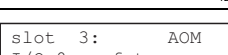
LCD display	Display/function
 12281E00	I/O data. The value for channel 0 is displayed on the left, for channel 7 on the right. For outputs that have not yet received any valid I/O data, the safety position "s" is displayed.
 12282E00	I/O error. † : wire breakage ≲ : short circuit
 12283E00	I/O data and error.
 12284E00	Display of the I/O data for individual channels. To display the submenu, press the ▲ and ▼ buttons simultaneously.
 12285E00	Display of I/O errors or I/O data. If no I/O value is available, the safety position is displayed. To switch between channels, press the ▲ and ▼ buttons simultaneously.

### Analogue module with HART

For HART Module 9468, the HART PV can be displayed.

The sub-menu only appears if the analogue modules for the transmission of HART PV are configured.

Only configured HART PVs are displayed.

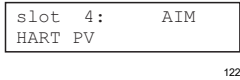
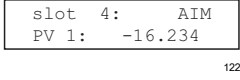
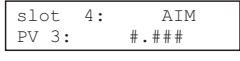
LCD display	Display/function
 12286E00	Menu for displaying the HART PV. To display the submenu, press the ▲ and ▼ buttons simultaneously.
 12287E00	Display of the configured PV. Operating mode 1 = 4 PV. Operating mode 2 = 8 PV. To change the PV, press the ▲ or ▼ button.
 12288E00	Display of "not a number".

### Temperature input module

In addition to the general displays, the Temperature Input Modules also has the following displays:

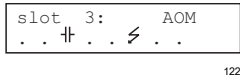
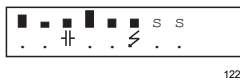
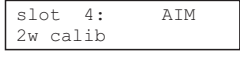
LCD display	Display/function
 12281E00	I/O data. The value for channel 0 is displayed on the left, for channel 7 on the right. For outputs that have not yet received any valid I/O data, the safety position "s" is displayed.
 12282E00	I/O error. † : wire breakage ⚡ : short circuit
 12283E00	I/O data and error.
 17025E00	Display of calibration

## 9.1.2 Start-Up

Display	Settings
 12258E00	<ul style="list-style-type: none"> <li>• After connecting the auxiliary power, the device will boot.</li> <li>• After successful completion of the booting process, the LCD display switches to the system level (shown on the left).</li> </ul>

### 9.1.3 Setting the Fieldbus Address

**i** The fieldbus address can be set only if the device is not in the Data Exchange mode.

Display	Settings
<pre>FBAdr  FB  I/O 120    OK  OK 12258E00</pre>	<ul style="list-style-type: none"> <li>Initial display (shown on the left)</li> </ul>
<pre>CPM      active 9440/15-01-11 12259E00</pre>	<ul style="list-style-type: none"> <li>Press the ▲ and ▼ buttons simultaneously. The following display appears (shown on the left).</li> </ul>
<pre>CPM      active FB addr : 5 12260E00</pre>	<ul style="list-style-type: none"> <li>Press the ▲ and ▼ buttons simultaneously. The following display appears (shown on the left).</li> </ul>
<pre>set FB address select: 5 12261E00</pre>	<ul style="list-style-type: none"> <li>Press the ▲ and ▼ buttons simultaneously. The following display appears (shown on the left).</li> </ul>
	<ul style="list-style-type: none"> <li>Press the ▲ or ▼ button until the desired fieldbus address has been set. Pressing and holding the button changes the value quickly. The adjustment range goes from 0 to 127.</li> </ul>
<pre>accept changes ? yes -&gt; CPM reset 12262E00</pre>	<ul style="list-style-type: none"> <li>Press the ▲ and ▼ buttons simultaneously. The following display appears (shown on the left).</li> </ul>
<pre>accept changes ? No 12263E00</pre>	<ul style="list-style-type: none"> <li>Press the ▲ and ▼ buttons simultaneously. The user adjustments are applied. The device boots again. or</li> <li>Press the ▲ or ▼ button. The following display appears (shown on the left).</li> </ul>
	<ul style="list-style-type: none"> <li>Press the ▲ and ▼ buttons simultaneously. The user adjustment is cancelled.</li> </ul>

**i** After setting the fieldbus address, the device boots again. The fieldbus address is permanently saved and is also available after reset or recommissioning.



## 10 Operation

### 10.1 Operation

After mounting, installation and commissioning (see the "Mounting and installation" and "Parameterisation and commissioning" chapters) the CPU & power module is ready for operation.

Please observe the additional documentation (coupling description).



The CPM and the Sub-D connectors can be plugged or unplugged safely during operation in hazardous areas (hot swap).

### 10.2 Indications

The corresponding LEDs on the device indicate the operating state of the device (see also the chapter "Function and device design").

LED	Colour	Meaning
"RUN" LED	Green	Operation indication
"ERR" LED	Red	Module error indication

### 10.3 Troubleshooting

For troubleshooting, refer to the following troubleshooting guide:

Error	Cause of error	Troubleshooting
"RUN" LED is lit, "ERR" LED is off	CPM: OK Common alarm I/O signal	See LED displays of the I/O modules
"RUN" LED is lit, "ERR" LED is flashing	CPM: OK, I/O: Common module alarm <ul style="list-style-type: none"> <li>• Module defective</li> <li>• Module not available</li> <li>• Wrong module plugged in</li> </ul>	<ul style="list-style-type: none"> <li>• Replace module</li> <li>• Plug in module</li> <li>• Plug in correct module</li> </ul>
"RUN" LED is flashing, "ERR" LED is off	In standby (switched on but no data exchange with master yet)	<ul style="list-style-type: none"> <li>• Activate the cyclical data transfer with the master.</li> <li>• Check master and bus connection to the CPM.</li> </ul>
"RUN" LED is flashing, "ERR" LED is flashing	Data Exchange has been quit (outputs are in safety position). Cyclical data transfer with master interrupted.	<ul style="list-style-type: none"> <li>• Activate the cyclical data transfer with the master.</li> <li>• Check master and bus connection to the CPM.</li> </ul>
"RUN" LED is flashing, "ERR" LED lights up	Configuration error. Configuration is not OK.	Change configuration of master.
"RUN" LED is off, "ERR" LED lights up/is flashing	CPM hardware error. <ul style="list-style-type: none"> <li>• Hardware check error</li> <li>• EPROM error</li> <li>• EEPROM error</li> </ul>	Replace CPM.
"RUN" LED is off, "ERR" LED is off	No supply voltage at the CPM or CPM defective.	<ul style="list-style-type: none"> <li>• Check the power supply of the CPM.</li> <li>• Check the CPM.</li> <li>• Check the BusRail.</li> <li>• Engage the CPM correctly on the BusRail.</li> <li>• Replace CPM.</li> </ul>

If the error cannot be eliminated using the specified procedures:

- Contact R. STAHL Schaltgeräte GmbH.

For rapid processing, have the following information ready:

- Type and serial number of the device
- DCS/PLC
- Protocol
- Revision no./firmware version
- Purchase information
- Error description
- Intended use (in particular input and output wiring)

## 11 Maintenance, Overhaul, Repair

### 11.1 Maintenance

- Consult the relevant national regulations to determine the type and extent of inspections.
- Adapt inspection intervals to the operating conditions.

During maintenance of the device, check at least:

- whether the clamping screws holding the electric lines are securely seated,
- whether the device enclosure and / or protective enclosure have cracks or other visible signs of damage,
- whether the permissible ambient temperatures are observed,
- whether the device is used according to its designated use.

### 11.2 Overhaul

The device does not require regular maintenance.

	Observe the relevant national regulations in the country of use.
---	--

### 11.3 Repair

	<b>DANGER</b>
	<p>Explosion hazard due to improper repair! Non-compliance results in severe or fatal injuries.</p> <ul style="list-style-type: none"> <li>• Repair work on the devices must be performed only by R. STAHL Schaltgeräte GmbH.</li> </ul>

### 11.4 Returning the Device

- Only return or package the devices after consulting R. STAHL!  
Contact the responsible representative from R. STAHL.

R. STAHL's customer service is available to handle returns if repair or service is required.

- Contact customer service personally.

or

- Go to the [r-stahl.com](http://r-stahl.com) website.
- Under "Support" > "RMA" > select "RMA-REQUEST".
- Fill out the form and send it.  
You will automatically receive an RMA form via email. Please print this file off.
- Send the device along with the RMA form in the packaging to  
R. STAHL Schaltgeräte GmbH (refer to chapter 1.1 for the address).

## 12 Cleaning

- To avoid electrostatic charging, the devices located in potentially explosive areas may only be cleaned using a damp cloth.
- When cleaning with a damp cloth, use water or mild, non-abrasive, non-scratching cleaning agents.
- Do not use aggressive detergents or solvents.

## 13 Disposal

- Observe national and local regulations and statutory regulation regarding disposal.
- Separate materials when sending it for recycling.
- Ensure environmentally friendly disposal of all components according to the statutory regulations.

## 14 Accessories and Spare Parts

<i><b>NOTICE</b></i>	
<p>Malfunction or damage to the device due to the use of non-original components. Non-compliance can result in material damage.</p> <ul style="list-style-type: none"> <li>• Use only original accessories and spare parts from R. STAHL Schaltgeräte GmbH.</li> </ul>	
	<p>For accessories and spare parts, see data sheet on our homepage <a href="http://r-stahl.com">r-stahl.com</a>.</p>

**EU-Konformitätserklärung**  
 EU Declaration of Conformity  
 Déclaration de Conformité UE



**R. STAHL Schaltgeräte GmbH • Am Bahnhof 30 • 74638 Waldenburg, Germany**  
 erklärt in alleiniger Verantwortung / declares in its sole responsibility / déclare sous sa seule responsabilité

dass das Produkt: **CPU & Power Modul mit Socket**  
 that the product: *CPU & Power Module with Socket*  
 que le produit: *Module CPU & Alimentation avec Embase*

Typ(en) / type(s) / type(s): **9440/22-01-e1 ( e = 1, 2 )**  
**9490/1b-12 ( b = 1, 3 )**

mit den Anforderungen der folgenden Richtlinien und Normen übereinstimmt.  
 is in conformity with the requirements of the following directives and standards.  
 est conforme aux exigences des directives et des normes suivantes.

Richtlinie(n) / Directive(s) / Directive(s)	Norm(en) / Standard(s) / Norme(s)
2014/34/EU <b>ATEX-Richtlinie</b> 2014/34/EU <i>ATEX Directive</i> 2014/34/UE <i>Directive ATEX</i>	EN IEC 60079-0:2018 EN 60079-1:2014 EN IEC 60079-7:2015/A1:2018 EN 60079-11:2012 EN 60079-18:2015/A1:2017
<b>Kennzeichnung für / marking for / marquage pour:</b> 9440/22-01-*1	II 2 G Ex db [ia Ga] [ib Gb] IIC T4 Gb <b>CE</b> 0158
9490/11-11 und 9490/11-12	II 2 G Ex db eb [ia Ga] [ib Gb] IIC T4 Gb <b>CE</b> 0158
9490/13-12	II 2 G Ex db mb [ia Ga] [ib Gb] IIC T4 Gb <b>CE</b> 0158
<b>EU-Baumusterprüfbescheinigung:</b> <i>EU Type Examination Certificate:</i> <i>Attestation d'examen UE de type:</i>	<b>KEMA 02 ATEX 1333 X</b> (DEKRA Certification B.V., Meander 1051, 6825 MJ Arnhem, Netherlands, NB0344)
<b>Produktnormen nach Niederspannungsrichtlinie:</b> <i>Product standards according to Low Voltage Directive:</i> <i>Normes des produit pour la Directive Basse Tension:</i>	EN 61010-1:2010/A1:2019/AC:2019-04
2014/30/EU <b>EMV-Richtlinie</b> 2014/30/EU <i>EMC Directive</i> 2014/30/UE <i>Directive CEM</i>	EN 61326-1:2013
2011/65/EU <b>RoHS-Richtlinie</b> 2011/65/EU <i>RoHS Directive</i> 2011/65/UE <i>Directive RoHS</i>	EN IEC 63000:2018

Waldenburg, 2023-02-14

**Ort und Datum**  
*Place and date*  
*Lieu et date*

i.V.

**Jörg Stritzelberger**  
 Leiter Entwicklung BU Automation  
 Director R&D Business Unit Automation  
 Directeur R&D Business Unit Automation

i.V.

**Daniel Groth**  
 Leiter Qualitätsmanagementsysteme  
 Director Quality Management Systems  
 Directeur Systèmes de Management de la Qualité

The copying, distribution and utilization of this document as well as the communication of its contents to others without expressed authorization is prohibited. Offenders will be held liable for the payment of damages. All rights reserved in the event of the grant of a patent, utility model or ornamental design registration.

Class I, DIV 2 / Zone 1 Installation  
for connection to I/O Modules located in  
Class I, II, III, Division 2, Group A-G,  
or Class I, Zone 1, Group IIC/IIB  
Hazardous (Classified) Locations

**CPM type 9440/22-01-\*1 with Socket type 9490/11-12**

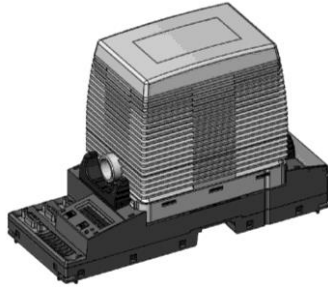

Class I, DIV 1 / Zone 1 Installation  
for connection to I/O Modules located in  
Class I, II, III, Division 1, Group A-G,  
or Class I, Zone 1, Group IIC/IIB  
Hazardous (Classified) Locations

**CPM type 9440/22-01-\*1 with Socket type 9490/12-12:**

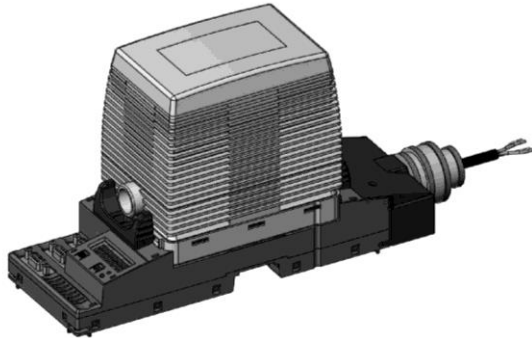

The CPM types 9440/22-01-\*1 are Explosion-proof modules for installation in Class I, Division 1 or Division 2, Group A-D or Class I, Zone 1, Group IIC/IIB areas; Providing intrinsically safe BusRail and RS485-IS interfaces according to NEC Article 504/505 or Canadian Electrical Code, CSA C22.

**Connection allocation**

CPU & Power Module (CPM) type 9440/22-01-\*1 for Division 1 or 2 or Zone 1 installation with Socket type 9490/1\*-12

**Power supply input Socket type 9490/11-12 (X5)**

CPM & Base Type	Power supply input	Function	Terminal no.
9440/22-01-11 and 9490/11-12	24 V DC (20 V ... 35 V DC)	+	1
		-	2
9440/22-01-21 and 9490/11-12	110 V AC, 230 V AC (90 V ... 253 V AC)	L	4
		N	6

**Power supply input Socket type 9490/12-12 (fixed cable)**

CPM & Base Type	Power supply input	Function	Cable no.
9440/22-01-11 and 9490/12-12	24 V DC (20 V ... 35 V DC)	+	1 (black)
		-	2 (black)
		Ground	4 (yellow-green)
9440/22-01-21 and 9490/12-12	110 V AC, 230 V AC (90 V ... 253 V AC)	L	3 (black)
		N	2 (black)
		Ground	4 (yellow-green)

**Fieldbus / Servicebus (RS 485 I (X1), RS 485 II (X2), RS 485 III (X3))**

Signal	Description	Pin
RXD / TXD-P	Received / transmitted data P, wire B	3
IS GND	Bus termination ground	5
IS P	Bus termination plus	6
RXD / TXD-N	Received / transmitted data N, wire A	8
	Not connected	1,2,4,7,9

Safety data for wiring configurations are as follows:

**Power Supply (input/primary):**

Conduit or type of protection Ex e:

Type 9440/22-01-11

$U_{in} = 24 \text{ V DC (20 V ... 35 V DC)}$   
 $I_{in} = 2.5 \text{ A at } 24 \text{ V DC}$   
 $U_m = 253 \text{ V AC}$

Type 9440/22-01-21

$U_{in} = 110 \text{ V AC, } 230 \text{ V AC (90 V ... 253 V AC)}$   
 $I_{in} = 500 \text{ mA at } 110 \text{ V AC; } 225 \text{ mA at } 230 \text{ V AC}$   
 $U_m = 253 \text{ V AC}$

**Fieldbus RS 485 -IS connections X1, X2, X3:**

CL I, II, III, DIV 1, A-G / CL I Zone 0, GP IIC/IIB:

$V_{OC} = \pm 3.7 \text{ V}$        $I_{SC} = 134 \text{ mA}$   
 $P_O = 124 \text{ mW}$        $V_{max} = \pm 4.2 \text{ V}$   
 $C_O = 1000 \mu\text{F}$        $L_O = 1.9 \text{ mH}$

**Module 1-8 over BusRail:**

CL I, DIV 1, A-D / CL I Zone 1, GP IIC/IIB:

Power Supply (output/secondary):

Maximum value:  $V_{OC} = 26.2 \text{ V}$

The system provides the required external current limitation for the circuit.

Address and data bus (secondary):

Maximum values:  $V_{OC} = 6.5 \text{ V}$   
 $I_{SC} = 116 \text{ mA}$   
 $P_O = 188 \text{ mW}$   
 $V_{max} = 6.6 \text{ V}$

Linear characteristic curve, the effective internal capacitance and inductance are negligibly small;  $C_o = 25 \mu\text{F}$ ,  $L_o = 2.5 \text{ mH}$

Follow the notes on the next page.

Weitergabe sowie Vervielfältigung dieses Dokuments, Verwertung und Mitteilung seines Inhalts sind verboten, soweit nicht ausdrücklich gestattet. Zuwiderhandlungen verpflichten zu Schadensersatz. Alle Rechte für den Fall der Patent-, Gebrauchsmuster- oder Geschmacksuntereintrag vorbehalten.

F 4830 503

			2018	Date	Name	<b>Certification drawing</b> <b>CPU &amp; Power Module, Type 9440/22-01-*1</b> <b>Socket Type 9490/1*-12</b>	Scale	none
			Drawn by	21.03.	Bagusch		Sheet	1 of 2
			Checked		Kaiser		Agency	FM
						<b>9440 6 031 001 1</b>		
Version	Date	Name				Rep. f.	Rep. t.	A4

**Notes:**

1. Connect either power supply 20... 35 V DC for the CPM 9440/22-01-11 or power supply 90...253 V AC for the CPM 9440/22-01-21. Never connect both power supply voltages.
2. Insulate unused wire.
3. Electrical Apparatus connected to an intrinsically safe system should not use or generate voltages > 253 V AC ( $U_m$ )
4. The CPM may be detached from the Socket or plugged onto it during operation in hazardous locations.
5. Make sure that the Socket's release levers are in position 1 before plug in the CPM. To unplug the CPM Module, set the release levers from position 1 to position 2 first, which disconnects the CPM from the Socket. Pull the CPM out of the base up to the intermediate position and then set the release levers to position 1 to take it off.
6. Intrinsically safe apparatus may be switches, thermocouples, LEDs, RTDs or an FM approved System or Entity device connected in accordance with the manufacturer's installation instructions.
7. For Entity concept use the appropriate parameters from above to ensure the following:  
 $V_{OC} \text{ or } V_t \leq V_{max}$      $C_a \geq C_i + C_{leads}$   
 $I_{SC} \text{ or } I_t \leq I_{max}$      $L_a \geq L_i + L_{leads}$
8. General Notes see Certification drawing for IS1 resp. IS1+ Remote I/O System No. 9400 6 031 003 1 or 9400 6 031 004 1.

**WARNING:** Do not disconnect the power supply input or the socket when a flammable or combustible atmosphere is present.  
**AVERTISSEMENT:** Ne pas débrancher l'entrée d'alimentation ou le socle en présence d'atmosphère inflammable ou combustible.

**Customer installation into a suitable enclosure IS1 resp. IS1+ for Class I, II, III, DIV 1 application with conduit Socket 9490/12-\*\*:**

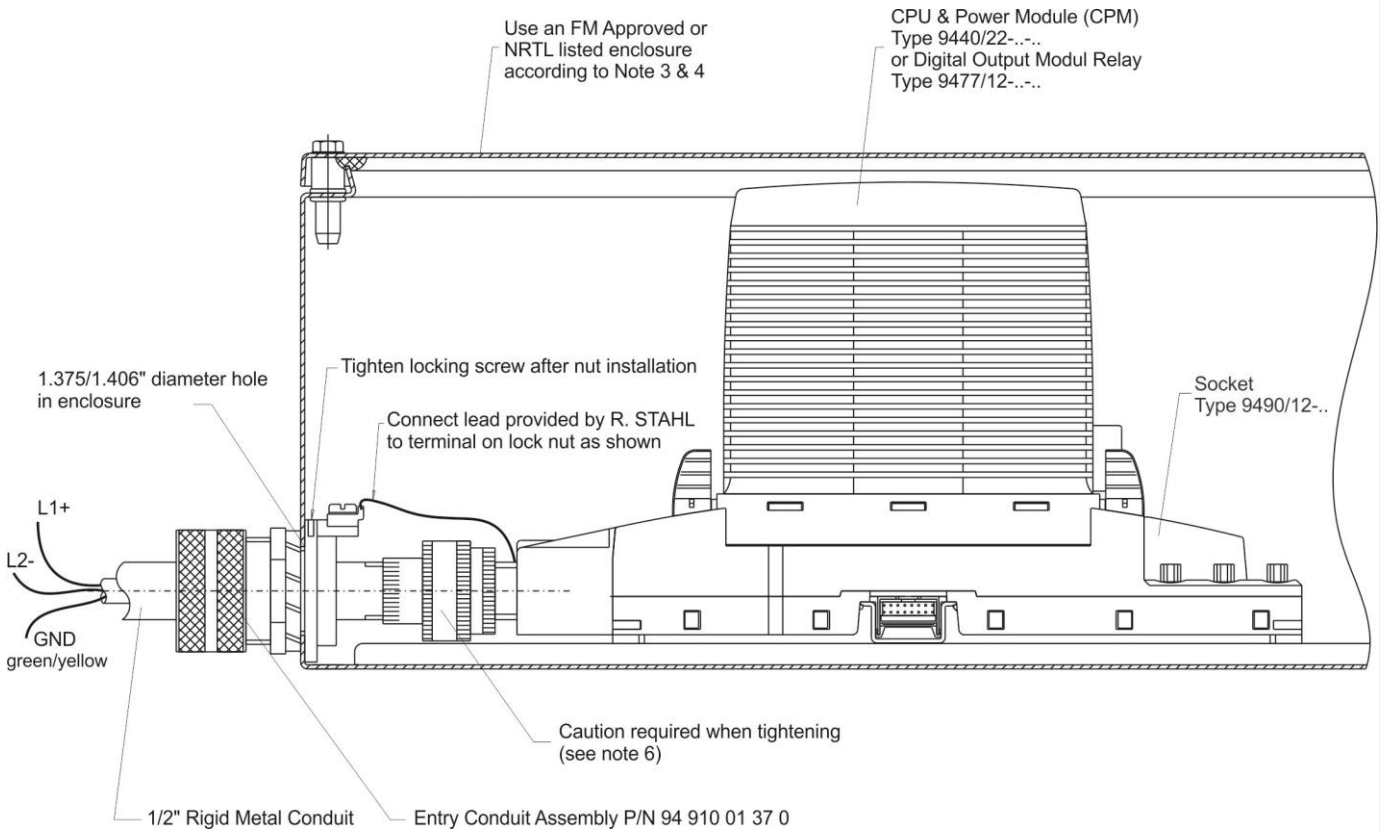

**Notes:**

1. Electrical apparatus connected to an intrinsically safe system should not use or generate voltages > 250 V AC ( $U_{max}$ ).
2. Installation should be in accordance with the National Electrical Code, AINSI/NFPA 70 resp. Canadian Electrical Code.
3. Use a general purpose enclosure meeting the requirements of ANSI/ISA 61010-1 for use in nonhazardous or Class I, Division 1 or Class I, Zone 1 hazardous (classified) locations.
4. Use an FM approved or NRTL listed Dust-Ignition proof enclosure appropriate for environmental protection in Class II and Class III, Hazardous (Classified) Location.
5. Entry Conduit Assembly P/N 94 910 01 37 0 provides a NEMA Type 4 environmental seal and Class II / III / dust / fiber seal.
6. Hand tightening of the union sleeve is sufficient to complete the assembly and sealing characteristics (however, a final tightening is required to prevent loosening through vibration).
7. The socket is factory sealed for the conduit entry.

F 4830 503

			2018	Date	Name	Certification drawing <b>CPU &amp; Power Module, Type 9440/22-01-*1</b> <b>Socket Type 9490/1*-12</b>	Scale
			Drawn by	21.03.	Bagusch		none
			Checked		Kaiser		Sheet
						<b>9440 6 031 001 1</b>	2 of 2
							Agency
Version	Date	Name					FM
						Rep. f.	Rep. t.
							A4

The copying, distribution and utilization of this document as well as the communication of its contents to others without expressed authorization is prohibited. Offenders will be held liable for the payment of damages. All rights reserved in the event of the grant of a patent, utility model or ornamental design registration.

**Example for Fieldbus System Topology with Bus Isolators interfacing Automation control systems with DIV 1 / Zone 1 installation of IS1 resp. IS1+ Remote I/O System:**

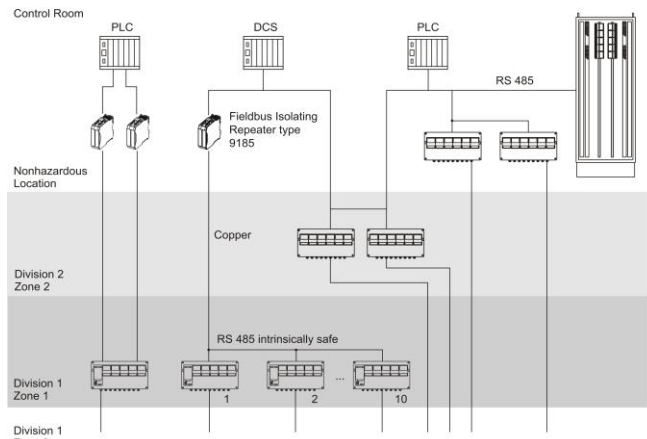

**Example for Ethernet System Topology with Isolators interfacing Automation control systems with DIV 1 / Zone 1 installation of IS1 resp. IS1+ Remote I/O System:**

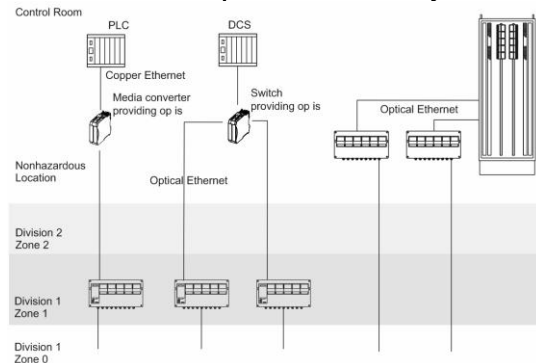

**Service Bus with Isolating Repeater interface:**

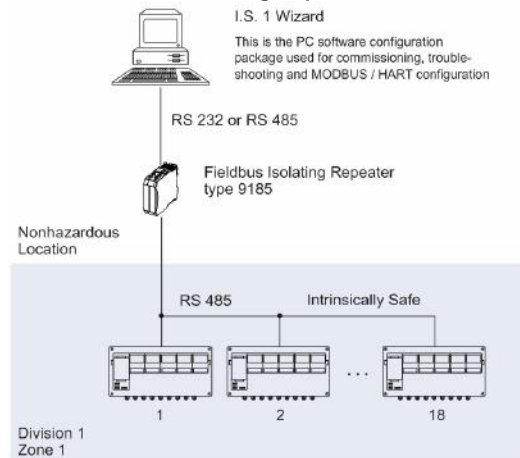

**Mounting direction:**

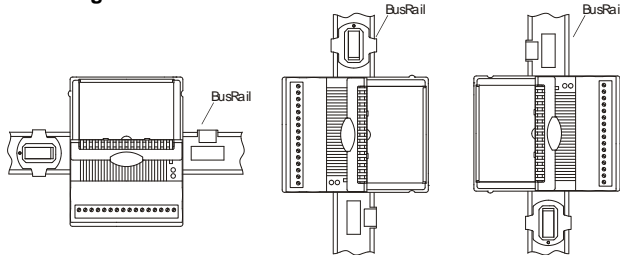

The IS1 resp. IS1+ Remote I/O is a DIN rail mounted system designed to record and output process control signals between hazardous location transducers, sensors and a nonhazardous location automation system. It consists of electrical apparatus in Class I, Division 1 or Class I, Zone 1 hazardous locations linked by an intrinsically safe field bus installed per the National Electrical Code, ANSI/NFPA 70 Article 500 or Canadian Electrical Code, CSA C22.

The intrinsically safe field bus circuit is achieved with the use of the Fieldbus Isolating Repeater type 9185 (copper to copper interface) or 9186 (fiber optic to copper interface). The Ethernet interface is achieved with the use of media converters and switches providing optical inherently safe Ethernet.

These devices reside in the nonhazardous location or in Division 2 or Zone 2 and provide a connection to the IS1 resp. IS1+ Remote I/O System. See examples to the left.

The apparatus located in the Division 1 or Zone 1 hazardous location are referred to as Remote I/O and consist of the following major subsystems.

**1. CPU & Power Module, Type 9440**

The CPU and Power Module contains a power supply unit for its own power supply, as well as for the supply to the I/O Modules and the field circuits. The power supply to the I/O Modules is implemented via the BusRail. For the configuration with a redundant CPU and Power Module the power supply to the I/O Modules is decoupled with diodes. The power supply unit has an undervoltage monitoring circuit. The CPU fulfills the function of a gateway between the internal bus of an IS1 field station and the fieldbus, which connects the field station with the automation system. The gateway is constructed as a dual processor system. The I/O processor controls the data exchange with the I/O Modules and, when plugged-in, with the redundant CPU & Power Module. The communication processor controls the data exchange on the fieldbus, the redundant fieldbus and on the Service Bus.

The communication with the I/O Modules is implemented via the address and data lines on the BusRail. The interface of the CPU & Power Module with the internal data bus on the BusRail is designed with redundancy.

**2. CPU Module Type 9441 and Power Module Type 9444**

The IS1 System for Ethernet uses a separate Power Module and CPU Module plugged onto an associated Socket instead of the CPU & Power Module Type 9440. Except for the external communication, which is achieved via optical fibre interface, the Power Module and the CPU Module provide similar functions as the CPU & Power Module type 9440.

**Components of Remote I/O System**

All I/O Modules are manufactured in a unique DIN rail mount package, which then mount onto the Remote I/O system BusRail.

**GENERAL NOTES:**

1. Installation should be in accordance with Article 504/505 of the National Electrical Code, ANSI/NFPA 70 and ANSI/ISA RP12.06.01.
2. Installation in Canada should be in accordance with the Canadian Electrical Code, CSA C22.1, Part 1
3. Use a general purpose enclosure meeting the requirements of ANSI/ISA 61010-1 for use in nonhazardous or Class I, Division 1 or Class I, Zone 1 hazardous (classified) locations.
4. Use an FM Approved or NRTL listed Dust-Ignition proof enclosure appropriate for environment protection in Class II and III, Division 1, Groups E, F and G, hazardous (classified) locations.
5. All I/O Modules may be detached from the BusRail or plugged onto it during operation in hazardous areas.
6. Mount the device in a vertical direction, with the reading of the marking from below, left or right, or in a horizontal direction with the terminals nearest the bottom of the enclosure. Never mount the IO modules upside down (terminals towards the top of the enclosure). As shown to the left.
7. Installation in Division 2 or Zone 2 is also allowed according to NEC Article 504/505 or Canadian Electrical Code, CSA C22. Therefore see drawing No. 9400 6 031 004 1.

WARNING: Substitution of components may impair Intrinsic Safety.  
 AVERTISSEMENT: Substitution de composants peut compromettre la sécurité intrinsèque.

Weitergabe sowie Vervielfältigung dieses Dokuments, Verwertung und Mitteilung seines Inhalts sind verboten, soweit nicht ausdrücklich gestattet. Zuwiderhandlungen verpflichten zu Schadensersatz. Alle Rechte für den Fall der Patent-, Gebrauchsmuster- oder Geschmacksuntereintrag vorbehalten.

F 4830 503

			2016	Date	Name	<b>Certification drawing</b> <b>IS1 resp. IS1+ Remote I/O System</b> <b>For CL I, DIV 1 / Zone 1</b> <b>Overview</b>	Scale	none
			Drawn by	03.03.	Bagusch		Sheet	1 of 2
			Checked		Kaiser		Agency	FM
Version	Date	Name				<b>9400 6 031 003 1</b>		
			Rep. f.		Rep. t.			A4



**Block Diagram of an RS485 Field Station:**

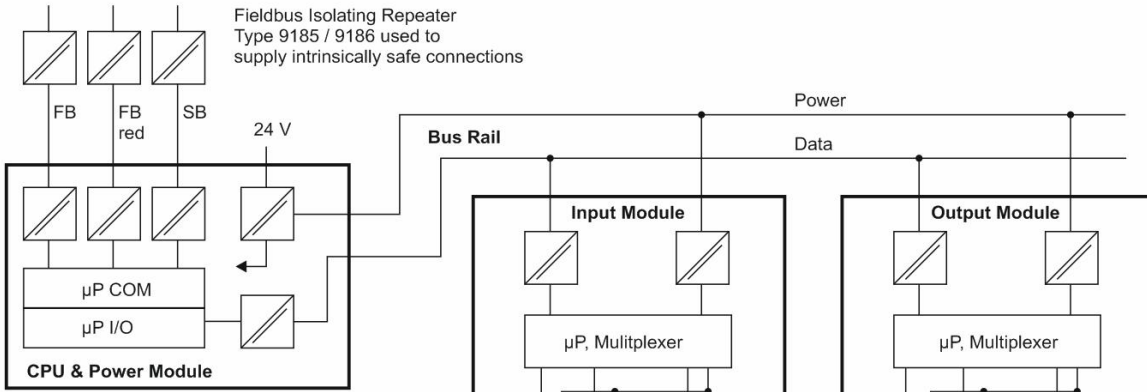

FB = Fieldbus  
 FB red = Fieldbus redundant  
 SB = ServiceBus

I.S. Inputs and Outputs  
 Class I, II, III, DIV 1, Groups A-G; Class I, Zone 0, IIC/IIB  
 or Non I.S. or Nonincendive circuits,  
 Class I, II, III, DIV 2, Group A-G; Class I, Zone 2, Group IIC/IIB

**Block Diagram of an Ethernet Field Station:**

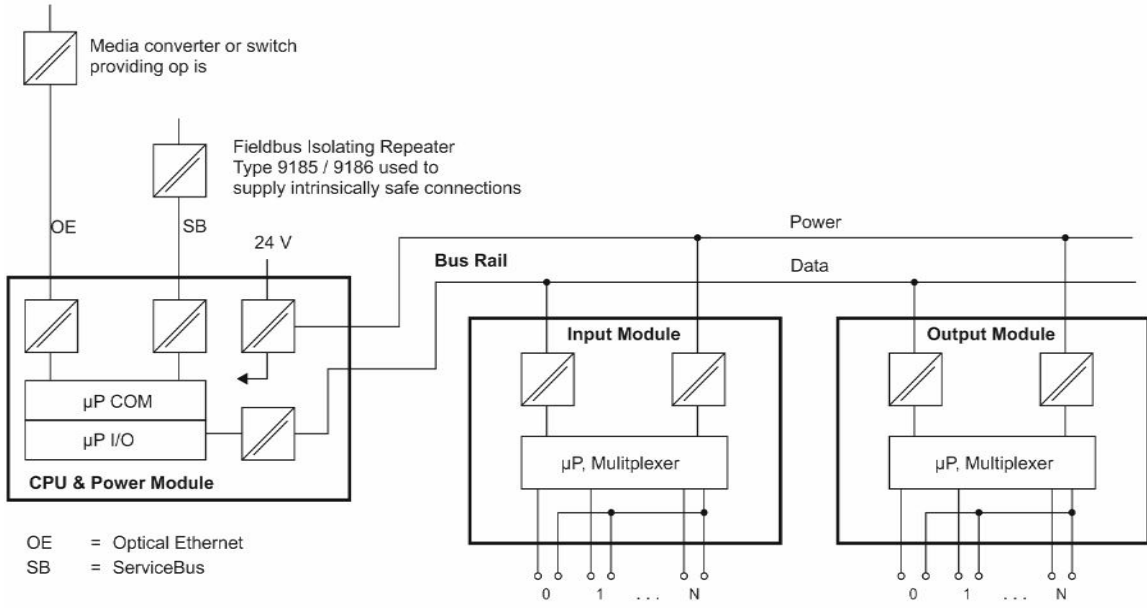

OE = Optical Ethernet  
 SB = ServiceBus

I.S. Inputs and Outputs  
 Class I, II, III, DIV 1, Groups A-G; Class I, Zone 0, IIC/IIB  
 or Non I.S. or Nonincendive circuits,  
 Class I, II, III, DIV 2, Group A-G; Class I, Zone 2, Group IIC/IIB

**Construction example for assembly of an IS1 resp. IS1+ System:  
 DIV 1 / Zone 1 assembly illustration shown**

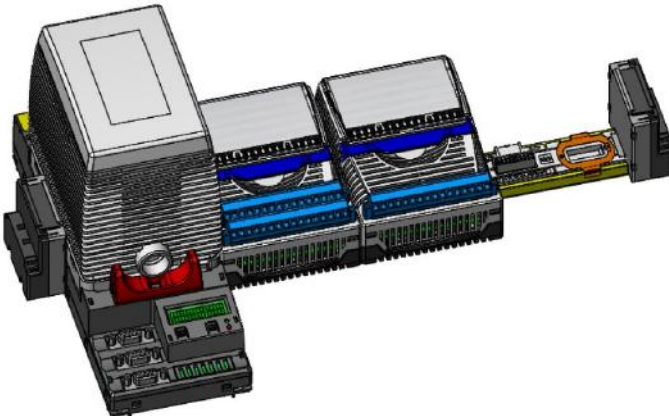

Version	Date	Name	2016	Date	Name	Certification drawing <b>IS1 resp. IS1+ Remote I/O System</b> For CL I, DIV 1 / Zone 1 <b>Overview</b>  9400 6 031 003 1	Scale	none
			Drawn by	03.03.	Bagusch		Sheet	2 of 2
			Checked		Kaiser		Agency	FM
			<b>STAHL</b>			Rep. f.	Rep. t.	A4

The copying, distribution and utilization of this document as well as the communication of its contents to others without expressed authorization is prohibited. Offenders will be held liable for the payment of damages. All rights reserved in the event of the grant of a patent, utility model or ornamental design registration.

**Example for System Topology interfacing Automation control systems with DIV 2 / Zone 2 installation of IS1 resp. IS1+ Remote I/O System:**

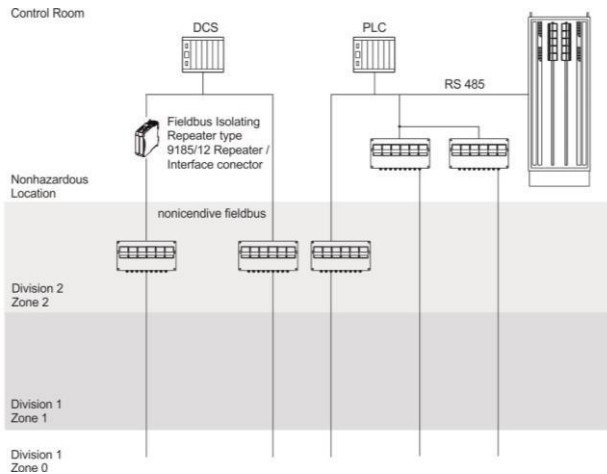

**Example for Ethernet System Topology with Isolators interfacing Automation control systems with DIV 2 / Zone 2 installation of IS1 resp. IS1+ Remote I/O System:**

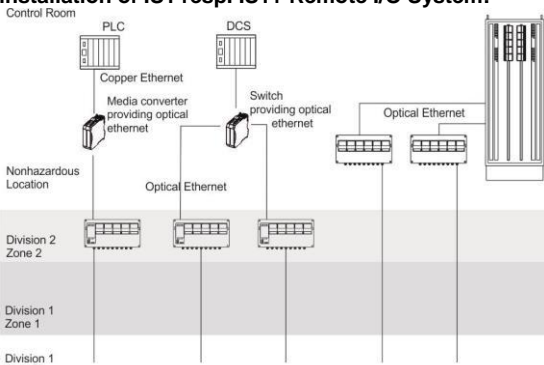

**Service Bus with Isolating Repeater interface:**

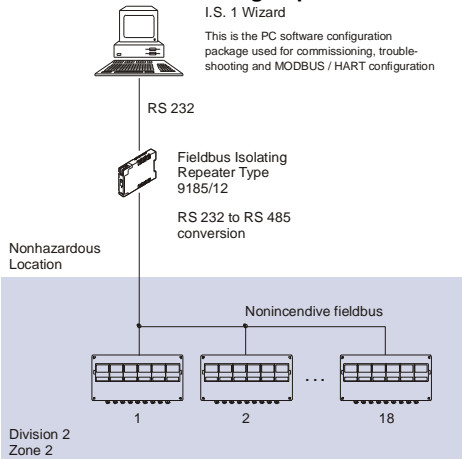

**Mounting direction:**

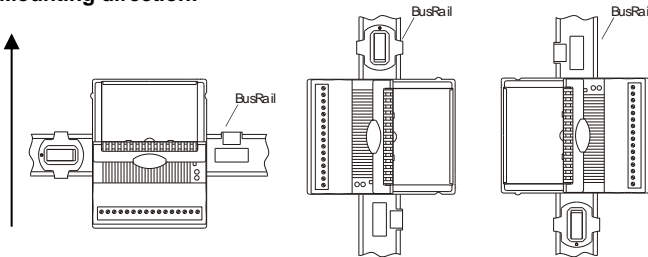

The IS1 resp. IS1+ Remote I/O is a DIN rail mounted system designed to record and output process control signals between hazardous location transducers and sensors and a nonhazardous location automation system. It consists of electrical apparatus in the nonhazardous, Class I, Division 2 or Class I, Zone 2 hazardous locations linked by either nonincendive field bus or a field bus installed per the National Electrical Code, ANSI/NFPA 70 Article 500 or Canadian Electrical Code, CSA C22.

Installation with the use of an appropriate fieldbus isolator for nonincendive fieldbus circuits (e.g. R. STAHL type 9185). The Ethernet interface is achieved with the use of media converters and switches providing optical Ethernet.

These devices reside in the unclassified (nonhazardous) location or Division 2 / Zone 2 locations and provide a connection to the IS1 resp. IS1+ Remote I/O System. See examples to the left.

The apparatus located in the Division 2 or Zone 2 hazardous location are referred to as Remote I/O, and consist of the following major subsystems.

- CPU & Power Module or CPU Module, Power Module & Socket**  
The CPU & Power Module or the Power Module serves as a power supply unit for its CPU unit or the CPU Module, as well as for the supply to the I/O Modules and the field circuits. The power supply to the I/O Modules is implemented via the BusRail. For the configuration with a redundant CPU and Power Module the power supply to the I/O Modules is decoupled with diodes. The power supply unit has an under voltage monitoring circuit. The CPU fulfils the function of a gateway between the internal bus of an IS1 field station and the fieldbus which connects the field station with the automation system. The gateway is constructed as a dual processor system. The I/O processor controls the data exchange with the I/O Modules and, when plugged-in, with the redundant CPU & Power Module. The communication processor controls the data exchange on the fieldbus and on the Service Bus.
- BusRail**  
The BusRail provides a Power bus, an internal data bus and the address lines for the interconnection of the CPU & Power Supply to Remote I/O Modules. The Power bus distributes power supplied by the CPU & Power Module to the I/O Modules plugged to the BusRail. The communication with the I/O Modules is implemented via the address and data bus lines. The interface of the CPU & Power Module with the internal data bus on the BusRail is designed with redundancy.
- Components of Remote I/O System**  
All I/O Modules are manufactured in a unique DIN rail mount package which then mounts onto the Remote I/O system BusRail. All I/O Modules provide galvanic isolation between the field circuits and the BusRail's circuits.

**GENERAL NOTES:**

- Installation should be in accordance with Article 504/505 of the National Electrical Code, ANSI/NFPA 70 and ANSI/ISA RP12.06.01.
- Installation in Canada should be in accordance with the Canadian Electrical Code, CSA C22.1, Part 1
- Use a general purpose enclosure meeting the requirements of ANSI/ISA 61010-1 for use in nonhazardous or Class I, Division 2 or Class I, Zone 2 hazardous (classified) locations.
- Use an FM Approved or NRTL listed Dust tight enclosure appropriate for environment protection in Class II and III, Division 2, Groups E, F and G, hazardous (classified) locations.
- All I/O Modules may be detached from the BusRail or plugged onto it during operation in hazardous areas.
- Mount the device in a vertical direction, with the reading of the marking from below, left or right, or in a horizontal direction with the terminals nearest the bottom of the enclosure. Never mount the IO modules upside down (terminals towards the top of the enclosure). As shown to the left.

WARNING: Substitution of components may impair Intrinsic Safety.  
AVERTISSEMENT: Substitution de composants peut compromettre la sécurité intrinsèque.

Weitergabe sowie Vervielfältigung dieses Dokuments, Verwertung und Mitteilung seines Inhalts sind verboten, soweit nicht ausdrücklich gestattet. Zuwiderhandlungen verpflichten zu Schadensersatz. Alle Rechte für den Fall der Patent-, Gebrauchsmuster- oder Geschmacksmusterrechte vorbehalten.

F 4830 503

			2016	Date	Name	Certification drawing <b>IS1 resp. IS1+ Remote I/O System</b> <b>for CL I, DIV 2 / Zone 2</b> <b>Overview</b>	Scale	none
			Drawn by	03.03.	Bagusch		Sheet	1 of 2
			Checked		Kaiser		Agency	FM
			<b>STAHL</b>					
Version	Date	Name				9400 6 031 004 1		
			Rep. f.		Rep. t.			A4

**Block Diagram of an RS485 Field Station:**

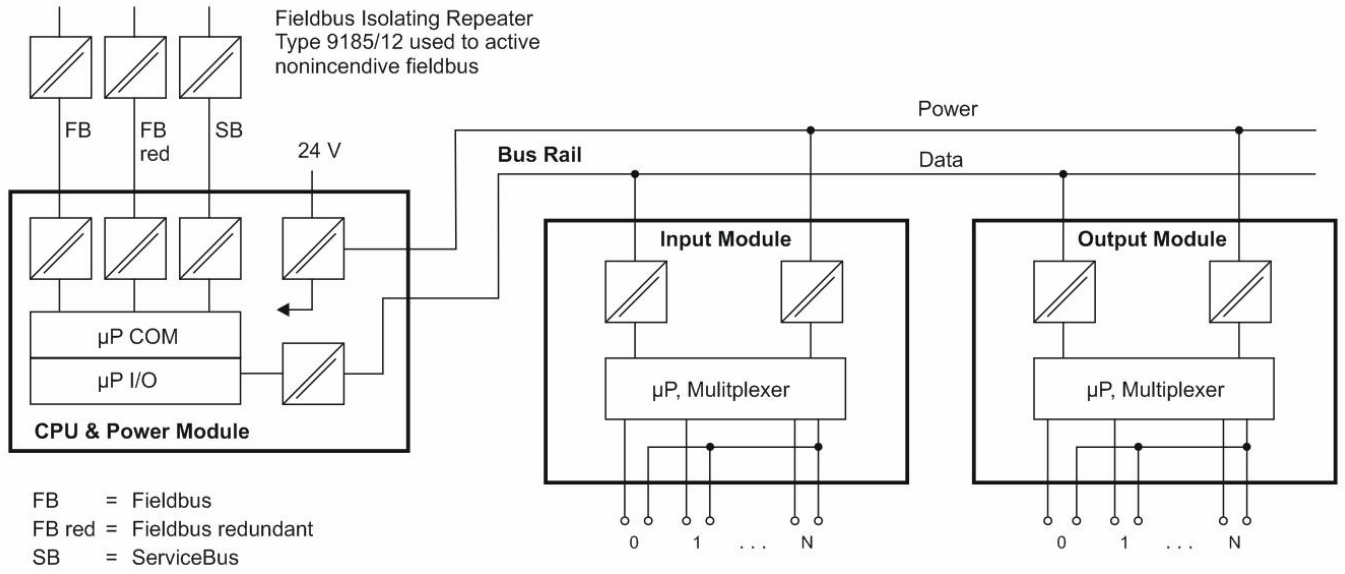

FB = Fieldbus  
 FB red = Fieldbus redundant  
 SB = ServiceBus

I.S. Inputs and Outputs  
 Class I, II, III, DIV 1, Groups A-G; Class I, Zone 0, IIC/IIB  
 or Non I.S. or Nonincendive circuits,  
 Class I, II, III, DIV 2, Group A-G; Class I, Zone 2, Group IIC/IIB

**Block Diagram of an Ethernet Field Station:**

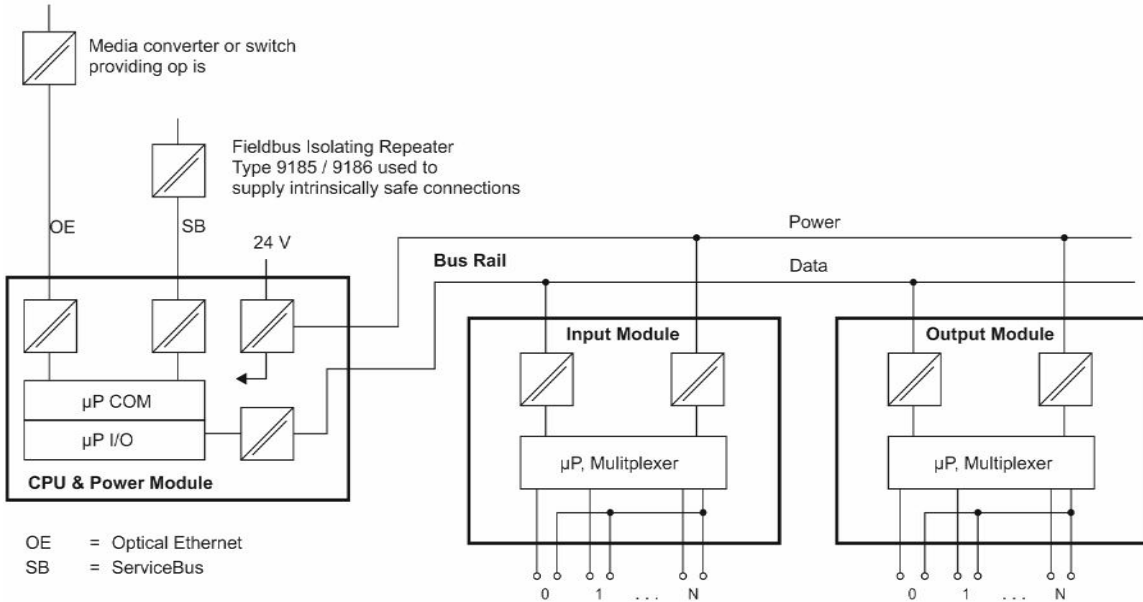

OE = Optical Ethernet  
 SB = ServiceBus

I.S. Inputs and Outputs  
 Class I, II, III, DIV 1, Groups A-G; Class I, Zone 0, IIC/IIB  
 or Non I.S. or Nonincendive circuits,  
 Class I, II, III, DIV 2, Group A-G; Class I, Zone 2, Group IIC/IIB

**Construction example for assembly of an IS1 resp. IS1+ System:  
 DIV 2 / Zone 2 assembly illustration shown**



2016	Date	Name	<b>Certification drawing</b> <b>IS1 resp. IS1+ Remote I/O System</b> <b>for CL I, DIV 2 / Zone 2</b> <b>Overview</b>	Scale
Drawn by	03.03.	Bagusch		none
Checked		Kaiser		Sheet 2 of 2
<b>STAHL</b>			<b>9400 6 031 004 1</b>	Agency FM
Version	Date	Name	Rep. f.	Rep. t.

Nonhazardous or  
Division 2 / Zone 2 Installation

Class I, II, III, Division 1, Group A-G  
or Class I, Zone 1, Group IIC/IIB  
Hazardous (Classified) Locations

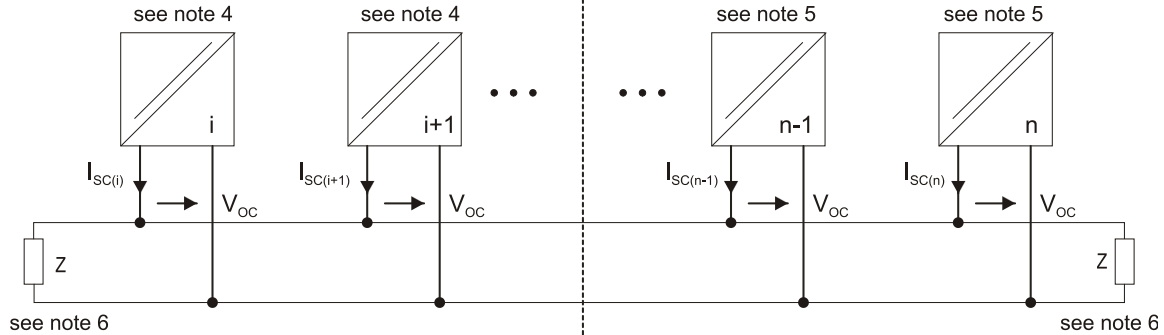

Intrinsically safe RS 485 for Fieldbus connection:

**CPM Type 9440/12-01-11**

Connections: X1, X2, X3, Pin 8, Pin 3

Maximum safety values:

$V_{OC} = \pm 3.7 \text{ V}$ ;  $I_{SC} = 107 \text{ mA}$ ;  $P_O = 96 \text{ mW}$   
(linear characteristics)

**CPM Type 9440/22-01-11 and 9440/22-01-21**

Connections: X1, X2, X3, Pin 3, 5, 6, 8

Maximum safety values:

$V_{OC} = \pm 3.7 \text{ V}$ ;  $I_{SC} = 134 \text{ mA}$ ;  $P_O = 124 \text{ mW}$   
(linear characteristics)

**CPU Module 9441, Power Module 9444 and Socket 9492**

Servicebus interface (X9 d-Sub connector at the sockets)

Maximum safety values:

$V_{OC} = \pm 3.7 \text{ V}$ ;  $I_{SC} = 134 \text{ mA}$ ;  $P_O = 124 \text{ mW}$   
(linear characteristics)

**Fieldbus Isolating Repeater Type 9185/11-35-10**

Connections: X3, Pin 3, 5, 6, 8

Entity parameters:

$V_{OC} = \pm 3.73 \text{ V}$   
 $I_{SC} = 149 \text{ mA}$   
 $P_O = 139 \text{ mW}$   
 $V_i = 4.2 \text{ V}$

**Fiber Optic Isolating Repeater Type 9186/12-11-1\***

Connections: X1, Pin 3, 5, 6, 8

Entity parameters:

$V_{OC} = \pm 3.7 \text{ V}$   
 $I_{SC} = 148 \text{ mA}$   
 $P_O = 137 \text{ mW}$   
 $V_i = 4.2 \text{ V}$

For the connection to an intrinsically safe RS 485 Field bus system with the type of protection intrinsically safe Class I, II, III, DIV 1, Group A-G; Class I, Zone 1, AEx ib IIC

- Maximum voltage value of each pair of terminals:  
 $V_{max} < \pm 3.75 \text{ V}$
- Maximum current value of the sum of terminal pairs:  
 $I_t = 2.66 \text{ A}$
- Wiring: cables with the following parameters:  
 $L' \leq 1.2 \text{ mH / km [0.366 mH / 1000 ft]}$   
 $R' > 2 \times 40 \text{ ohms / km [24.39 ohms / 1000 ft]}$   
(loop resistance)  
 $C' \leq 250 \text{ nF / km [76 pF / ft]}$

Standard wire diameter  $\geq 0.2 \text{ mm}$  (#34AWG)

Concentrated inductances and capacitances are not permissible along the intrinsically safe RS 485 Field bus system.

- Associated electrical apparatus
- Intrinsically safe apparatus
- Terminating resistor Z: value  $> 143 \text{ ohms} + 1\%$ ,  $> 400 \text{ mW}$ , with a thermal rating of  $140 \text{ K/W}$ . This resistor is included in the STAHL Fieldbus connector.
- Installation should be in accordance with Article 504/505 of the National Electrical Code, ANSI/NFPA 70 and ANSI/ISA RP12.06.01.
- Installation in Canada should be in accordance with the Canadian Electrical Code, CSA C22.1, Part 1
- For Installation in Division 1 or Zone 1 see also Certification drawing for IS1 resp. IS1+ Remote I/O System No. 9400 6 031 003 1 as part of the documentation of the CPU & Power Modules.
- For Installation in Division 2 or Zone 2 see also Certification drawing for IS1 resp. IS1+ Remote I/O System No. 9400 6 031 004 1 or 9400 6 031 006 1 as part of the documentation of the CPU & Power Modules.

F 4830 503

			2016	Date	Name	<b>Certification drawing</b> <b>IS1 resp. IS1+ Remote I/O System</b> <b>Intrinsically Safe RS 485</b> <b>Fieldbus Connection</b>	Scale
			Drawn by	03.03.	Bagusch		none
			Checked		Kaiser		Sheet
							1 of 1
							Agency
						9400 6 031 005 1	FM
01	09.03.2018	Bagusch					
Version	Date	Name					
						Rep. f.	Rep. t.
							A4

