



## CPU & Power Modul für Zone 2 / Class I, Div. 2

Reihe 9440/15

**Inhaltsverzeichnis**

1	Allgemeine Angaben.....	3
1.1	Hersteller.....	3
1.2	Angaben zur Betriebsanleitung.....	3
1.3	Weitere Dokumente .....	3
1.4	Konformität zu Normen und Bestimmungen .....	3
2	Erläuterung der Symbole .....	4
2.1	Symbole in der Betriebsanleitung .....	4
2.2	Warnhinweise .....	4
2.3	Symbole am Gerät.....	5
3	Sicherheitshinweise .....	5
3.1	Aufbewahrung der Betriebsanleitung.....	5
3.2	Qualifikation des Personals .....	5
3.3	Sichere Verwendung.....	6
3.4	Umbauten und Änderungen.....	7
4	Funktion und Geräteaufbau .....	7
4.1	Funktion .....	8
4.2	Geräteaufbau .....	8
5	Technische Daten .....	9
6	Projektierung.....	13
6.1	Anschlussbelegung steckbare Klemme X5.....	13
6.2	Anschlussbelegung Sub-D-Buchsen X1, X2, X3 .....	13
7	Transport und Lagerung .....	14
8	Montage und Installation.....	14
8.1	Maßangaben / Befestigungsmaße.....	14
8.2	Montage / Demontage, Gebrauchslage .....	15
8.3	Installation.....	16
9	Parametrierung und Inbetriebnahme .....	17
9.1	Parametrierungen .....	17
10	Betrieb.....	23
10.1	Betrieb.....	23
10.2	Anzeigen .....	23
10.3	Fehlerbeseitigung .....	23
11	Instandhaltung, Wartung, Reparatur.....	24
11.1	Instandhaltung .....	24
11.2	Wartung .....	24
11.3	Reparatur.....	24
11.4	Rücksendung .....	25
12	Reinigung.....	25
13	Entsorgung.....	25
14	Zubehör und Ersatzteile.....	25

# 1 Allgemeine Angaben

## 1.1 Hersteller

R. STAHL Schaltgeräte GmbH  
Am Bahnhof 30  
74638 Waldenburg  
Germany

Tel.: +49 7942 943-0  
Fax: +49 7942 943-4333  
Internet: r-stahl.com  
E-Mail: info@r-stahl.com

## 1.2 Angaben zur Betriebsanleitung

ID-Nr.: 162278 / 9440609310  
Publikationsnummer: 2024-03-07-BA00-III-de-09

Die Originalbetriebsanleitung ist die deutsche Ausgabe.  
Diese ist rechtsverbindlich in allen juristischen Angelegenheiten.

## 1.3 Weitere Dokumente

- Kopplungsbeschreibung IS1+ (Download unter r-stahl.com)
  - Datenblatt
  - Nationale Informationen und Dokumente zum Einsatz in explosionsgefährdeten Bereichen (siehe auch Kapitel 1.4)
- Dokumente in weiteren Sprachen, siehe r-stahl.com.

## 1.4 Konformität zu Normen und Bestimmungen



IECEX, ATEX, EU-Konformitätserklärung und weitere nationale Zertifikate und Dokumente stehen unter folgendem Link zum Download bereit:  
<https://r-stahl.com/de/global/support/downloads/>

Je nach Geltungsbereich können zusätzliche, ex-relevante Informationen als Anhang beigefügt sein.

IECEX zusätzlich unter: <https://www.iecex.com/>

## 2 Erläuterung der Symbole



### 2.1 Symbole in der Betriebsanleitung

Symbol	Bedeutung
	Tipps und Empfehlungen zum Gebrauch des Geräts
	Gefahr durch explosionsfähige Atmosphäre



### 2.2 Warnhinweise

Warnhinweise unbedingt befolgen, um das konstruktive und durch den Betrieb bedingte Risiko zu minimieren. Die Warnhinweise sind wie folgt aufgebaut:

- Signalwort: GEFAHR, WARNUNG, VORSICHT, HINWEIS
- Art und Quelle der Gefahr/des Schadens
- Folgen der Gefahr
- Ergreifen von Gegenmaßnahmen zum Vermeiden der Gefahr bzw. des Schadens

	<b>GEFAHR</b>
	Gefahren für Personen Nichtbeachtung der Anweisung führt zu schweren oder tödlichen Verletzungen bei Personen.
	<b>WARNUNG</b>
	Gefahren für Personen Nichtbeachtung der Anweisung kann zu schweren oder tödlichen Verletzungen bei Personen führen.
	<b>VORSICHT</b>
	Gefahren für Personen Nichtbeachtung der Anweisung kann zu leichten Verletzungen bei Personen führen.
	<b>HINWEIS</b>
	Vermeidung von Sachschaden Nichtbeachtung der Anweisung kann zu einem Sachschaden am Gerät und/oder seiner Umgebung führen.

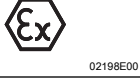
## 2.3 Symbole am Gerät

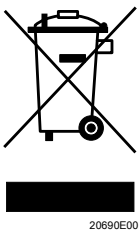
Symbol	Bedeutung
	CE-Kennzeichnung gemäß aktuell gültiger Richtlinie.
	Stromkreis gemäß Kennzeichnung für explosionsgefährdete Bereiche zertifiziert.
	Sicherheitshinweise, welche unerlässlich zur Kenntnis genommen werden müssen: Bei Geräten mit diesem Symbol sind die entsprechenden Daten und / oder die sicherheitsrelevanten Hinweise der Betriebsanleitung zu beachten!
	Kennzeichnung gemäß WEEE-Richtlinie 2012/19/EU

## 3 Sicherheitshinweise

### 3.1 Aufbewahrung der Betriebsanleitung

- Betriebsanleitung sorgfältig lesen.
- Betriebsanleitung am Einbauort des Geräts aufbewahren.
- Mitgeltende Dokumente und Betriebsanleitungen der anzuschließenden Geräte beachten.

### 3.2 Qualifikation des Personals

Für die in dieser Betriebsanleitung beschriebenen Tätigkeiten ist eine entsprechend qualifizierte Fachkraft erforderlich. Dies gilt vor allem für Arbeiten in den Bereichen

- Projektierung
- Montage/Demontage des Geräts
- (Elektrische) Installation
- Inbetriebnahme
- Instandhaltung, Reparatur, Reinigung

Fachkräfte, die diese Tätigkeiten ausführen, müssen einen Kenntnisstand haben, der relevante nationale Normen und Bestimmungen umfasst.

Für Tätigkeiten in explosionsgefährdeten Bereichen sind weitere Kenntnisse erforderlich! R. STAHL empfiehlt einen Kenntnisstand, der in folgenden Normen beschrieben wird:

- IEC/EN 60079-14 (Projektierung, Auswahl und Errichtung elektrischer Anlagen)
- IEC/EN 60079-17 (Prüfung und Instandhaltung elektrischer Anlagen)
- IEC/EN 60079-19 (Gerätereparatur, Überholung und Regenerierung)

### 3.3 Sichere Verwendung

#### Vor der Montage

- Sicherheitshinweise in dieser Betriebsanleitung lesen und beachten!
- Sicherstellen, dass der Inhalt dieser Betriebsanleitung vom zuständigen Personal voll verstanden wurde.
- Gerät nur bestimmungsgemäß und nur für den zugelassenen Einsatzzweck verwenden.
- Bei Betriebsbedingungen, die durch die technischen Daten des Geräts nicht abgedeckt werden, unbedingt bei der R. STAHL Schaltgeräte GmbH rückfragen.
- Sicherstellen, dass das Gerät unbeschädigt ist.
- Für Schäden, die durch fehlerhaften oder unzulässigen Einsatz des Geräts sowie durch Nichtbeachtung dieser Betriebsanleitung entstehen, besteht keine Haftung.



#### Bei Montage und Installation

- Montage und Installation nur durch qualifizierte und autorisierte Personen (siehe Kapitel "Qualifikation des Personals") durchführen lassen.
- Gerät nur in Bereichen installieren, für die es aufgrund seiner Kennzeichnung geeignet ist.
- Bei Installation und im Betrieb die Angaben (Kennwerte und Bemessungsbedingungen) auf Typ- und Datenschildern sowie die Hinweisschilder am Gerät beachten.
- Vor Installation sicherstellen, dass das Gerät unbeschädigt ist.
- Gerät bei Einsatz in Zone 2 in ein schützendes Gehäuse oder einen Schrank gemäß IEC/EN 60079-0 einbauen, die jeweils eine geeignete Schutzart (mindestens IP54) aufweisen.
- Gerät bei Einsatz in Zone 22 in ein schützendes Gehäuse oder einen Schrank gemäß IEC/EN 60079-31 einbauen, die jeweils eine geeignete Schutzart (mindestens IP64) aufweisen.
- Bei Einsatz in Zone 22 darf das System nur in einem für Bereiche mit Staub (geschützt durch Gehäuse) zugelassenem Gehäuse eingebaut werden. Der Monteur muss sicherstellen, dass die Anforderungen der IEC/EN 60079-31 z.B. hinsichtlich Staubablagerungen und zulässiger Temperatur erfüllt sind.
- Betrachtung bzw. Berechnung der Wärmeentwicklung im Gehäuse durchführen.
- Bei Einsatz in Class I, Division 2, Gerät gemäß Control drawing installieren!
- Bei Einsatz im sicheren Bereich in einer Umgebung gemäß IEC/EN 60664-1 mit Verschmutzungsgrad 1 oder 2 und Überspannungskategorie I, II oder III installieren.
- Beim Betrieb zusammen mit Ex i Stromkreisen die nicht-eigensicheren Klemmen mit einer Abdeckung schützen, die der Schutzart IP30 entspricht. Bei fehlender Abdeckung: Gehäuse nur im spannungslosen Zustand des Geräts öffnen.
- Das Modul darf ausschließlich in vertikaler oder horizontaler Lage und nur auf der BusRail 9494 montiert werden.
- Hutschiene der BusRail 9494 mit dem Potentialausgleich verbinden.

**Inbetriebnahme, Wartung, Reparatur**

- Inbetriebnahme und Instandsetzung nur durch qualifizierte und autorisierte Personen (siehe Kapitel "Qualifikation des Personals") durchführen lassen.
- Vor Inbetriebnahme sicherstellen, dass das Gerät unbeschädigt ist.
- Nur Wartungsarbeiten durchführen, die in dieser Betriebsanleitung beschrieben sind.
- Gerät nur mit feuchtem Tuch reinigen, um elektrostatische Aufladung zu vermeiden.
- Vor der Demontage bzw. dem Wechsel des Moduls in explosionsfähiger Atmosphäre Hilfsenergie spannungsfrei schalten.

**3.4 Umbauten und Änderungen**

	<p style="text-align: center;"><b>GEFAHR</b></p> <p>Explosionsgefahr durch Umbauten und Änderungen am Gerät! Nichtbeachten führt zu schweren oder tödlichen Verletzungen.</p> <ul style="list-style-type: none"> <li>• Gerät nicht umbauen oder verändern.</li> </ul>
	<p>Für Schäden, die durch Umbauten und Änderungen entstehen, besteht keine Haftung und keine Gewährleistung.</p>

**4 Funktion und Geräteaufbau**

	<p style="text-align: center;"><b>GEFAHR</b></p> <p>Explosionsgefahr durch zweckentfremdete Verwendung! Nichtbeachten führt zu schweren oder tödlichen Verletzungen.</p> <ul style="list-style-type: none"> <li>• Gerät nur entsprechend den in dieser Betriebsanleitung festgelegten Betriebsbedingungen verwenden.</li> <li>• Gerät nur entsprechend dem in dieser Betriebsanleitung genannten Einsatzzweck verwenden.</li> </ul>
---	---

### 4.1 Funktion

Das CPU & Power Modul 9440/15 hat die Funktion eines Gateways zwischen dem internen Bus einer IS1+ Feldstation und dem Feldbus, der die Feldstation einfach oder redundant mit dem Automatisierungssystem verbindet.

#### Einsatzbereich

Das Gerät ist für IS1+ Feldstationen bestimmt und darf in explosionsgefährdeten Bereichen der Zone 2 / Class I, Div. 2 oder Zone 22 installiert werden.

#### Stromversorgung und Kommunikation

Das Modul enthält ein Netzteil zur eigenen Stromversorgung als auch für die Versorgung der I/O-Module und der Feldstromkreise. Die Stromversorgung der I/O-Module erfolgt über die BusRail. Beim Einsatz eines redundanten CPU & Power Moduls ist die Stromversorgung der I/O-Module intern mit Dioden entkoppelt aufgebaut. Das Netzteil ist mit einer Unterspannungs-Überwachung ausgestattet.

Die Kommunikation mit den I/O-Modulen erfolgt über die Adress- und Datenleitungen der BusRail. Die Schnittstelle des CPU & Power Moduls zum internen Datenbus der BusRail ist redundant ausgeführt.

### 4.2 Geräteaufbau

	#	Geräteelement	Beschreibung
	1	Abdeckklappe	Abdeckklappe mit Einlegeschild und Anschlussplan (geöffnet)
	2	LCD-Anzeige	Anzeige von Diagnosedaten, Eingangs- und Ausgangswerten
	3	Beschriftung	Angaben zum Modul (Seriennummer, Hardware-Revisionsnummer, Software-Revisionsnummer, Herstelldatum, z.B.: 123456DE9999 Rev. A 01-01 0508)
	4	Tasten	Tasten <down>, <up>
	5	Rasthebel	Rasthebel zum Entfernen des Moduls von der BusRail
	6	LED	LED zur Anzeige Betrieb ("RUN", grün) und Fehler ("ERR", rot) (weitere Informationen siehe Kapitel "Anzeigen")
	7	Sub-D-Buchse X1	Prozessbus, primär
	8	Sub-D-Buchse X2	Prozessbus, redundant (nur mit PROFIBUS DP nutzbar!)
	9	Sub-D-Buchse X3	Service Bus
	10	Klemme X5	Hilfsenergie, Steckbare Klemme mit zwei Sicherungsschrauben



## 5 Technische Daten

### Explosionsschutz

#### Global (IECEX)

Gas	IECEX PTB 14.0039X Ex ec [ia Ga] [ib Gb] IIC T4 Gc
-----	---

#### Europa (ATEX, UKEX)

Gas	PTB 99 ATEX 2222 Ⓜ II 3 (2) G Ex ec [ia Ga] [ib Gb] IIC T4 Gc
-----	--

### Bescheinigungen und Zertifikate

Bescheinigungen	IECEX, ATEX, cFMus (Kanada, USA), CCC (China), KTL (Süd-Korea), INMETRO (Brasilien)
Schiffszertifikate	EU RO Mutual Recognition (inkl. ABS, BV, CCS, CRS, DNV GL, IRS, KR, LR, ClassNK, PRS, RINA, RS)

### Weitere Parameter

Installation in	Zone 2 / Class I, Div. 2 und im sicheren Bereich
Weitere Angaben	siehe jeweilige Bescheinigung und Betriebsanleitung

### Technische Daten

#### Elektrische Daten

Hilfsenergie	
Nennspannung	24 V DC
Spannungsbereich	20 ... 35 V DC
Stromaufnahme	
ohne I/O-Module	0,3 A bei 24 V
mit 8 I/O-Modulen	ca. 2,5 A bei 24 V
mit 16 I/O-Modulen	ca. 4,9 A bei 24 V
Verlustleistung	
ohne I/O-Module	7,2 W
je I/O-Modul	ca. 1 W
Verpolschutz	ja
Unterspannungsüberwachung	ja

**Technische Daten**

Schnittstellen Feldbus, Feldbus redundant und Service Bus	
Schnittstelle	RS485
Leitungslänge / Übertragungsrate	
Kupferkabel	1200 m bei 9,6 ... 93,75 kbit/s 1000 m bei 187,5 kbit/s 400 m bei 500 kbit/s 200 m bei 1,5 Mbit/s
Hinweis	für größere Längen LWL-Technik verfügbar
Lichtwellenleiter	ca. 2000 m bei 1,5 Mbit/s
Service Bus	1200 m bei 9,6 kbit/s
Leitungsabschluss	entsprechend Feldbus Standard
Adresseinstellung	0 ... 127
Redundanz	Systemredundanz
PROFIBUS DP	
Versionen	DP V0, DP V1, DP V1 HART
Übertragungs- geschwindigkeit	9,6 kbit/s ... 1,5 Mbit/s
Datenübertragung	ca. 40 16-Bit-Worte / ms (zyklisch, netto bei 1,5 Mbit/s)
Modbus RTU	
Übertragungs- geschwindigkeit	9,6 ... 38,4 kbit/s
Datenübertragung	ca. 1000 16-Bit-Register/s (bei 38,4 kbit/s)
Funktionen	Read, Write; siehe Kopplungsbeschreibung Modbus RTU
Kennwerte	
Max. interne Signalverzögerung bei 8 I/O-Modulen (ohne Modul- verzögerung)	
für Digital Module	7 ms
für Analog Module	10 ms
Bediener- Schnittstelle	
Software	IS1+ Geräte DTM oder IS Wizard
Betrieb	LED "RUN", grün
Fehler	LED "ERR", rot
LCD-Anzeige	2 x 16 Zeichen
Einstellungen	Busadresse
Anzeigen	Busadresse, Alarme / Fehler, Informationen (Typ, Revision usw.) für die Ebenen Feldstation, Module und Signale, Werte der Eingänge und Ausgänge

**Technische Daten**

Diagnose und Parametrierung	
Funktionen	<ul style="list-style-type: none"> <li>• Konfigurationsdaten und Parameter in IS1+ Feldstationen laden oder rücklesen</li> <li>• Eingänge lesen</li> <li>• Ausgänge lesen und schreiben</li> <li>• Diagnosedaten übertragen (z.B. Konfig-Fehler, Hardware-Fehler, Signal-Fehler)</li> <li>• HART Kommandos von / zu HART Feldgeräten übertragen</li> </ul>
Anschließbare Softwarepakete	<ul style="list-style-type: none"> <li>• IS Wizard (über R. STAHL Service Bus)</li> <li>• R. STAHL DTM</li> <li>• AMS von Emerson Process Management</li> <li>• PDM von Siemens</li> <li>• PRM und Fieldmate von Yokogawa</li> <li>• FieldCare von Endress + Hauser</li> <li>• FDM von Honeywell</li> <li>• etc.</li> </ul>
Stromversorgung für I/O-Module über die BusRail	
Spannungsbereich	22,5 ... 26,2 V DC
Max. Strom	4 A
Max. Anzahl I/O-Module	16
Redundante Versorgung der I/O-Module	ja
Unterspannungsüberwachung	ja
Galvanische Trennung	
zwischen Hilfsenergie und Systemkomponenten	1500 V AC
zwischen Feldbus-/Service Bus-Schnittstelle und Systemkomponenten	1500 V AC
zwischen zwei Bus-Schnittstellen	500 V AC
Elektromagnetische Verträglichkeit	Geprüft nach folgenden Normen und Vorschriften: EN 61326-1, EN 61000-4-1...6, NAMUR NE 21

**Technische Daten****Umgebungsbedingungen**

Umgebungs- temperatur	-20 ... +65 °C
Lagertemperatur	-40 ... +70 °C
Relative Feuchte (keine Betauung)	< 95 %
Verwendung in Höhe	< 2000 m
Schock, halbsinusförmig (IEC/EN 60068-2-27)	15 g (3 Schocks pro Achse und Richtung)
Vibration, sinusförmig (IEC/EN 60068-2-6)	1 g im Frequenzbereich 10 ... 500 Hz 2 g im Frequenzbereich 45 ... 100 Hz

**Mechanische Daten**

Anschluss	
Feldbus RS485	Sub-D Buchse 9-polig
Service Bus RS485	Sub-D Buchse 9-polig
Hilfsenergie	Steckbare Schraubklemmen mit Arretierung 4,0 mm <sup>2</sup>
Schutzart (IEC 60529)	
Module	IP30
Anschlüsse	IP20
Modulgehäuse	Polyamid 6GF
Brandfestigkeit (UL 94)	V2

**Montage / Installation**

Einbaubedingungen	
Montageart	auf 35-mm-DIN-Schiene NS 35/15
Einbaulage	waagrecht und senkrecht

Weitere technische Daten, siehe [r-stahl.com](http://r-stahl.com).

## 6 Projektierung

### HINWEIS

Ausfall der installierten Geräte im Schaltschrank durch zu hohe Umgebungstemperatur!

Nichtbeachten kann zu Sachschäden führen.

- Schaltschrank so aufbauen und einrichten, dass alle darin installierten Geräte immer innerhalb ihres zulässigen Temperaturbereichs betrieben werden.

Bei der Projektierung folgende Bedingungen beachten:

- Installation des Geräts zur bestimmungsgemäßen Verwendung nur auf der IS1+ BusRail 9494.
- Drei zulässige Montagelagen für den Betrieb des Geräts: siehe Kapitel "Montage / Demontage auf BusRail".
- An dem Gerät können bis zu 16 I/O-Module, bei ausschließlicher Verwendung von Analog Modulen bis zu 15 I/O-Module betrieben werden.
- Das primäre Gerät muss auf dem ersten Steckplatz der BusRail 9494 montiert sein.
- Das redundante Gerät (optional) muss auf dem zweiten Steckplatz der BusRail 9494 montiert sein.
- Die Hutschiene der BusRail 9494 muss mit dem Potentialausgleich des explosionsgefährdeten Bereichs verbunden sein.
- An den angeschlossenen Hilfsenergie-Stromkreisen darf nur im spannungsfreien Zustand gearbeitet werden.

### 6.1 Anschlussbelegung steckbare Klemme X5

Die Hilfsenergie wird am CPM Modul über eine steckbare Klemme X5 angeschlossen (im Lieferumfang des Moduls enthalten).

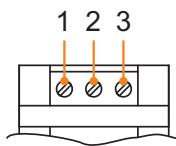
	Funktion	Klemmen-Nr.
	+24 V DC	1
	0 V	2
	kein Leiteranschluss	3

### 6.2 Anschlussbelegung Sub-D-Buchsen X1, X2, X3

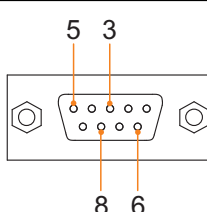
	Pin-Nr.	Funktion	Beschreibung
	3	RxD/TxD (+)	Daten B (+)
	5	GND	Bezugspotential für Geräteschnittstelle
	6	5 V (+)	Versorgungsspannung (Gerät)
	8	RxD/TxD (-)	Daten A (-)
	übrige Pins	–	nicht angeschlossen

## 7 Transport und Lagerung

- Gerät nur in Originalverpackung transportieren und lagern.
- Gerät trocken (keine Betauung) und erschütterungsfrei lagern.
- Gerät nicht stürzen.

## 8 Montage und Installation

Das Gerät ist für den Einsatz in gasexplosionsgefährdeten Bereichen der Zone 2, in staubexplosionsgefährdeten Bereichen der Zone 22 sowie auch im sicheren Bereich zugelassen.

<b>GEFAHR</b>	
	<p><b>Explosionsgefahr durch falsche Installation des Geräts!</b> Nichtbeachten führt zu schweren oder tödlichen Verletzungen.</p> <ul style="list-style-type: none"> <li>• Installation strikt nach Anleitung und unter Berücksichtigung der nationalen Sicherheits- und Unfallverhütungsvorschriften durchführen, damit der Explosionsschutz erhalten bleibt.</li> <li>• Das elektrische Gerät so auswählen bzw. installieren, dass der Explosionsschutz aufgrund äußerer Einflüsse nicht beeinträchtigt wird, z.B. Druckbedingungen, chemische, mechanische, thermische, elektrische Einflüsse sowie Schwingungen, Feuchte, Korrosion (siehe IEC/EN 60079-14).</li> <li>• Gerät nur durch geschultes und mit den einschlägigen Normen vertrautes Fachpersonal installieren lassen.</li> </ul>

### 8.1 Maßangaben / Befestigungsmaße

Maßzeichnungen (alle Maße in mm [Zoll]) – Änderungen vorbehalten

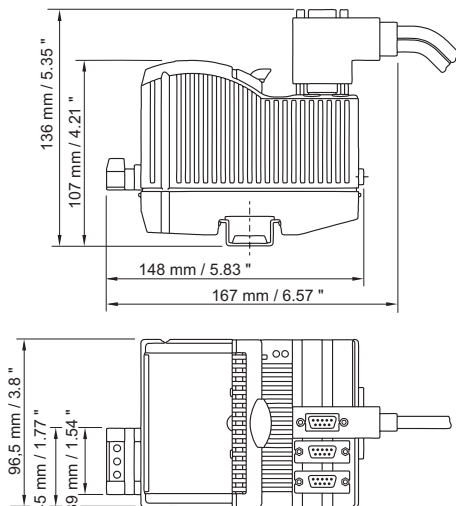

09878E00

## 8.2 Montage / Demontage, Gebrauchslage

### 8.2.1 Montage / Demontage

#### HINWEIS

Fehlfunktion oder Geräteschaden durch unsachgemäße Montage.  
Nichtbeachten kann Sachschaden verursachen!

- Gerät ausschließlich vertikal montieren, mit Lese-Richtung der LCD-Anzeige wahlweise von unten, von links oder von rechts.

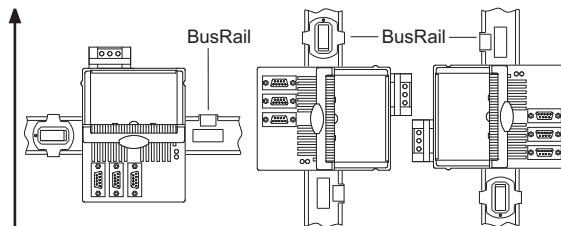

12228E00

#### Montage auf BusRail

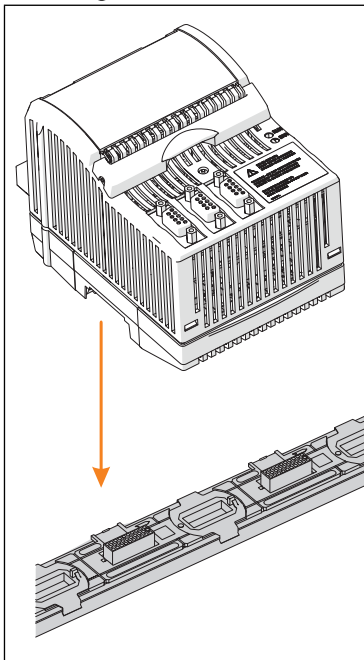

22319E00

- Modul senkrecht auf den ersten Steckplatz der BusRail aufsetzen und durch leichtes Drücken einrasten.
- Um sicherzustellen, dass das Modul richtig eingerastet ist, nochmals links und rechts das Modul auf die BusRail drücken!  
Zwischen Modul und BusRail sollte keine Lücke sein!  
Modul darf sich ohne Betätigen des Rasthebels nicht mehr lösen lassen.
- Steckbare Klemme X5 auf Modul stecken und mit den Sicherungsschrauben gegen Lockern sichern  
(Anzugsdrehmoment 0,5 ... 0,6 Nm).

## 8.2.2 Voraussetzungen für Demontage / Modulwechsel

Vor der Demontage bzw. dem Wechsel des Moduls Folgendes beachten:

- Hilfsenergie spannungsfrei schalten.

### Demontage

- Schrauben der steckbaren Klemme X5 lösen.
- Steckbare Klemme X5 vom auszutauschenden Modul abziehen.
- Feldbusanschlüsse von den Sub-D-Buchsen entfernen.
- Blauen Rasthebel des Moduls nach oben ziehen, um das Modul zu entriegeln.
- Modul senkrecht von BusRail abziehen.

### Modulwechsel (nach Demontage)

- Neues Modul senkrecht auf vorgesehenen Steckplatz der BusRail aufsetzen und durch leichtes Drücken einrasten.
- Um sicherzustellen, dass das Modul richtig eingerastet ist, nochmals links und rechts das Modul auf die BusRail drücken.  
Dabei prüfen: Zwischen Modul und BusRail sollte keine Lücke sein!  
Das Modul darf sich ohne Betätigen des Rasthebels nicht mehr lösen lassen!
- Feldbusse wieder an Sub-D-Buchsen anschließen.
- Steckbare Klemme X5 auf Modul stecken und mit Schrauben gegen Lockern sichern (Anzugsdrehmoment 0,5 ... 0,6 Nm).

## 8.3 Installation



Bei Betrieb unter erschwerten Bedingungen wie insbesondere auf Schiffen sind zusätzliche Maßnahmen zur korrekten Installation je nach Einsatzort zu treffen. Weitere Informationen und Anweisungen hierzu erhalten Sie gerne auf Anfrage von Ihrem zuständigen Vertriebskontakt.

### 8.3.1 Hilfsenergie anschließen

- Hilfsenergie an der Klemme X5 anschließen (siehe Kapitel 6.1).  
Die Nennspannung der Hilfsenergie beträgt 24 V DC (siehe Datenblatt).
- Steckbare Klemme am das CPU & Power Modul mit Schrauben gegen Lockern sichern (Anzugsdrehmoment 0,5 ... 0,6 Nm)

### 8.3.2 Feldbus anschließen

- Primären Feldbus an Sub-D-Buchse X1 anschließen.
- Gegebenenfalls redundanten Feldbus an Sub-D-Buchse X2 anschließen (nur mit PROFIBUS DP möglich!).
- Sub-D-Stecker mit Schrauben gegen Lockern sichern (Anzugsdrehmoment 0,5 ... 0,6 Nm).

### 8.3.3 Service Bus anschließen

- Service Bus an Sub-D-Buchse X3 anschließen.
- Sub-D-Stecker mit Schrauben gegen Lockern sichern (Anzugsdrehmoment 0,5 ... 0,6 Nm).



## 9 Parametrierung und Inbetriebnahme

	GEFAHR
	<p>Explosionsgefahr durch fehlerhafte Installation!                  Nichtbeachten führt zu schweren oder tödlichen Verletzungen.</p> <ul style="list-style-type: none"> <li>• Gerät vor der Inbetriebnahme auf korrekte Installation prüfen.</li> <li>• Nationale Bestimmungen einhalten.</li> </ul>

Vor Inbetriebnahme Folgendes sicherstellen:

- Vorschriftsmäßige Installation des Geräts.
- Richtiger Anschluss der Leitungen.
- Keine Schäden am Gerät und an Anschlussleitungen.
- Fester Sitz der Schrauben an den Klemmen.  
 Richtiges Anzugsdrehmoment: 0,5 ... 0,6 Nm.

### 9.1 Parametrierungen

Die Parametrierung und Inbetriebnahme des CPM und der angeschlossenen I/O-Module erfolgt über das Automatisierungssystem und den Service Bus (optional).

Nur die Feldbusadresse des CPM muss direkt am Modul eingestellt werden.

Über die LCD-Anzeige mit Tasten lassen sich

- die Feldbusadresse des Geräts einstellen
- Informationen über das Gerät und die auf der BusRail installierten I/O-Modulen anzeigen (siehe Kapitel "Anzeigen").

#### 9.1.1 LCD-Anzeigen

Zur Anzeige eines bestimmten Moduls wechseln

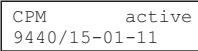
LCD-Anzeige	Einstellungen
 <small>12258E00</small>	<ul style="list-style-type: none"> <li>• Ausgangsanzeige (links dargestellt)</li> </ul>
 <small>12259E00</small>	<ul style="list-style-type: none"> <li>• Tasten ▲ und ▼ gleichzeitig drücken, um von Systemebene in Modulebene zu wechseln. Es erscheint folgende Anzeige (links dargestellt).</li> <li>• Mit der Taste ▲ und ▼ gewünschtes Modul auswählen.</li> </ul>
	<ul style="list-style-type: none"> <li>• Tasten ▲ und ▼ gleichzeitig drücken. Die Anzeige wechselt in die Informationsebene.</li> <li>• Mit der Taste ▲ oder ▼ zwischen verschiedenen LCD-Anzeigen wechseln (siehe folgende Tabelle).</li> </ul>

### Anzeige Status-Informationen der CPM

LCD-Anzeige	Anzeige/Funktion																				
<pre>CPM      active FB addr : 5</pre> <small>12260E00</small>	Zustand und Feldbus-Adresse des Geräts.																				
<pre>CPM information Modbus   V10-00</pre> <small>12264E00</small>	Kopplungsart																				
<pre>CPM      status config/para fail</pre> <small>12265E00</small>	<p>Status des Geräts.</p> <p>Mögliche Status-Informationen:</p> <table border="1"> <thead> <tr> <th>Status-Information in LCD-Anzeige</th> <th>Bedeutung</th> </tr> </thead> <tbody> <tr> <td>no error</td> <td>kein Fehler</td> </tr> <tr> <td>hardware fail (1)</td> <td>Hardwarefehler gefunden</td> </tr> <tr> <td>hardware fail (2)</td> <td>falsche Hardware-Kennung</td> </tr> <tr> <td>hardware fail (3)</td> <td>keine Kommunikation zwischen CPR und IOP</td> </tr> <tr> <td>DataExch AS</td> <td>Data Exchange mit Automatisierungssystem, Konfiguration durch PROFIBUS</td> </tr> <tr> <td>DataExch AS (2)</td> <td>Data Exchange mit dem Automatisierungssystem</td> </tr> <tr> <td>no DataExch</td> <td>kein Datenaustausch</td> </tr> <tr> <td>config/para fail</td> <td>Konfigurations- oder Parameterfehler</td> </tr> <tr> <td>quit DataExch</td> <td>kein Datenaustausch mehr</td> </tr> </tbody> </table>	Status-Information in LCD-Anzeige	Bedeutung	no error	kein Fehler	hardware fail (1)	Hardwarefehler gefunden	hardware fail (2)	falsche Hardware-Kennung	hardware fail (3)	keine Kommunikation zwischen CPR und IOP	DataExch AS	Data Exchange mit Automatisierungssystem, Konfiguration durch PROFIBUS	DataExch AS (2)	Data Exchange mit dem Automatisierungssystem	no DataExch	kein Datenaustausch	config/para fail	Konfigurations- oder Parameterfehler	quit DataExch	kein Datenaustausch mehr
Status-Information in LCD-Anzeige	Bedeutung																				
no error	kein Fehler																				
hardware fail (1)	Hardwarefehler gefunden																				
hardware fail (2)	falsche Hardware-Kennung																				
hardware fail (3)	keine Kommunikation zwischen CPR und IOP																				
DataExch AS	Data Exchange mit Automatisierungssystem, Konfiguration durch PROFIBUS																				
DataExch AS (2)	Data Exchange mit dem Automatisierungssystem																				
no DataExch	kein Datenaustausch																				
config/para fail	Konfigurations- oder Parameterfehler																				
quit DataExch	kein Datenaustausch mehr																				
<pre>CPM      active back</pre> <small>12266E00</small>	Tasten ▲ und ▼ gleichzeitig drücken. Wechsel zurück in die Modulebene des Geräts.																				
<pre>CPM      active exit menu</pre> <small>12267E00</small>	Tasten ▲ und ▼ gleichzeitig drücken. Wechsel zurück zur Hauptanzeige des Geräts.																				

### Zur Anzeige eines bestimmten Moduls wechseln

LCD-Anzeige	Einstellungen
<pre>FBAdr  FB  I/O 120    OK  OK</pre> <small>12258E00</small>	<ul style="list-style-type: none"> <li>Ausgangsanzeige (links dargestellt)</li> </ul>
<pre>CPM      active 9440/15-01-11</pre> <small>12259E00</small>	<ul style="list-style-type: none"> <li>Tasten ▲ und ▼ drücken, um von Systemebene in Modulebene zu wechseln. Es erscheint folgende Anzeige (links dargestellt).</li> <li>Mit der Taste ▲ und ▼ gewünschtes Modul auswählen.</li> </ul>
	<ul style="list-style-type: none"> <li>Tasten ▲ und ▼ gleichzeitig drücken. Die Anzeige wechselt in die Informations-/Serviceebene.</li> </ul>

### Anzeige Status-Informationen des I/O-Moduls

<b>i</b>	Die folgenden Anzeigen sind für alle I/O-Module gleich aufgebaut.
----------	---

LCD-Anzeige	Anzeige/Funktion																								
<div style="border: 1px solid black; padding: 2px; margin-bottom: 5px;">                     slot 2: AOM                      module OK/mode:0                 </div> <p style="font-size: small; margin-left: 20px;">12268E00</p>	<p>Anzeige des Steckplatzes, des Modultyps und des Modulzustands.</p> <p>Mögliche Modulzustände:</p> <table border="1" style="width: 100%; border-collapse: collapse;"> <thead> <tr> <th style="width: 40%;">Status-Information in LCD-Anzeige</th> <th style="width: 40%;">Bedeutung</th> <th style="width: 20%;">Prio</th> </tr> </thead> <tbody> <tr> <td>IOM no response</td> <td>Kommunikation mit dem Modul ist nicht möglich. Modul ist defekt, nicht gesteckt oder beide BusRail bzw. das BusRail-Verbindungsleitung sind gestört</td> <td style="text-align: center;">1</td> </tr> <tr> <td>hardware failure</td> <td>Modul meldet Hardwarefehler</td> <td style="text-align: center;">2</td> </tr> <tr> <td>conf unequal mod</td> <td>Konfigurationsfehler oder falsches Modul gesteckt</td> <td style="text-align: center;">3</td> </tr> <tr> <td>HW disable outp.</td> <td>Ausgänge durch externen Schalter (Anlagen Aus) abgeschaltet (nur bei DOM 9475/2)</td> <td style="text-align: center;">4</td> </tr> <tr> <td>prim. Rail fail</td> <td>keine Kommunikation über primären BusRail-Datenbus</td> <td style="text-align: center;">5</td> </tr> <tr> <td>red. Rail fail</td> <td>keine Kommunikation über redundanten BusRail-Datenbus</td> <td style="text-align: center;">5</td> </tr> <tr> <td>module OK/mode: x</td> <td>Modul in Ordnung. Kein Modulfehler. Signalfehler können trotzdem vorhanden sein. Zusätzlich wird die konfigurierte Betriebsart (mode:x) angezeigt</td> <td style="text-align: center;">6</td> </tr> </tbody> </table> <p>Bei mehreren Fehlern wird nur der Fehler mit der höchsten Priorität angezeigt. Nach Beheben dieses Fehlers wird der Fehler mit der nächsthöheren Priorität angezeigt.</p>	Status-Information in LCD-Anzeige	Bedeutung	Prio	IOM no response	Kommunikation mit dem Modul ist nicht möglich. Modul ist defekt, nicht gesteckt oder beide BusRail bzw. das BusRail-Verbindungsleitung sind gestört	1	hardware failure	Modul meldet Hardwarefehler	2	conf unequal mod	Konfigurationsfehler oder falsches Modul gesteckt	3	HW disable outp.	Ausgänge durch externen Schalter (Anlagen Aus) abgeschaltet (nur bei DOM 9475/2)	4	prim. Rail fail	keine Kommunikation über primären BusRail-Datenbus	5	red. Rail fail	keine Kommunikation über redundanten BusRail-Datenbus	5	module OK/mode: x	Modul in Ordnung. Kein Modulfehler. Signalfehler können trotzdem vorhanden sein. Zusätzlich wird die konfigurierte Betriebsart (mode:x) angezeigt	6
Status-Information in LCD-Anzeige	Bedeutung	Prio																							
IOM no response	Kommunikation mit dem Modul ist nicht möglich. Modul ist defekt, nicht gesteckt oder beide BusRail bzw. das BusRail-Verbindungsleitung sind gestört	1																							
hardware failure	Modul meldet Hardwarefehler	2																							
conf unequal mod	Konfigurationsfehler oder falsches Modul gesteckt	3																							
HW disable outp.	Ausgänge durch externen Schalter (Anlagen Aus) abgeschaltet (nur bei DOM 9475/2)	4																							
prim. Rail fail	keine Kommunikation über primären BusRail-Datenbus	5																							
red. Rail fail	keine Kommunikation über redundanten BusRail-Datenbus	5																							
module OK/mode: x	Modul in Ordnung. Kein Modulfehler. Signalfehler können trotzdem vorhanden sein. Zusätzlich wird die konfigurierte Betriebsart (mode:x) angezeigt	6																							
<div style="border: 1px solid black; padding: 2px; margin-bottom: 5px;">                     slot 1: AOM                      FW 02-04, HW 'E'                 </div> <p style="font-size: small; margin-left: 20px;">12269E00</p>	Anzeige der Firmware- und der Hardware-Revision.																								
<div style="border: 1px solid black; padding: 2px; margin-bottom: 5px;">                     slot 3: AOM                      SNo: 123456-7890                 </div> <p style="font-size: small; margin-left: 20px;">12270E00</p>	Anzeige der Seriennummer.																								

### Digital Modul

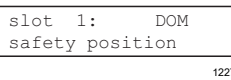
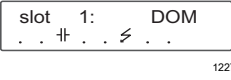
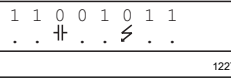
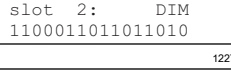
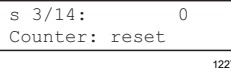
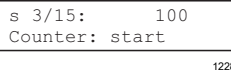

Zusätzlich zu den allgemeinen Anzeigen gibt es bei Digital Modulen noch folgende Anzeigen:

LCD-Anzeige	Anzeige/Funktion
	Ohne Ausgabedaten wird Sicherheitszustand der Ausgänge angezeigt. (nur bei Output Module)
	I/O-Fehler. ‡: Drahtbruch ⚡: Kurzschluss
	I/O-Daten und -Fehler.
	I/O-Daten. Der Wert für Kanal 0 steht links, der für Kanal 15 rechts.
	Anzeige des Zähler-/Frequenzwertes und der Steuerbits "start" und "reset" für Kanal 14. (nur bei Input Modul)
	Anzeige des Zähler-/Frequenzwertes und der Steuerbits "start" und "reset" für Kanal 15. (nur bei Input Modul)

### Analog Modul

Zusätzlich zu den allgemeinen Anzeigen gibt es bei dem Analog Modul noch die folgende Anzeige, siehe Tabelle.

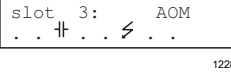
Bei Verwendung von HART beim Modul 9468 gibt es noch zusätzliche Menüpunkte (siehe "Analog Modul mit HART")

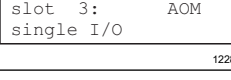
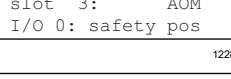
LCD-Anzeige	Anzeige/Funktion
	I/O-Daten. Der Wert für Kanal 0 steht links, der für Kanal 7 rechts. Bei Ausgängen, die noch keine gültigen I/O-Daten erhalten haben, wird die Sicherheitsstellung "s" angezeigt.
	I/O-Fehler. ‡: Drahtbruch ⚡: Kurzschluss
	I/O-Daten und -Fehler.
	Anzeige der I/O-Daten für einzelne Kanäle. Aufruf des Untermenüs durch gleichzeitiges Drücken der Tasten ▲ und ▼ .
	Anzeige von I/O-Fehler oder I/O-Daten. Ist kein I/O-Wert vorhanden, wird die Sicherheitsstellung angezeigt. Wechseln zwischen Kanälen durch gleichzeitiges Drücken der Tasten ▲ und ▼ .

### Analog Modul mit HART

Für das HART Modul 9468 können die HART PV dargestellt werden.  
Das Untermenü erscheint nur, wenn die Analog Module für die Übertragung von HART PV konfiguriert sind.

Es werden nur die konfigurierten HART PV angezeigt.

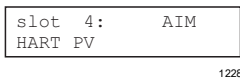
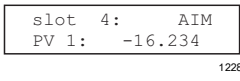
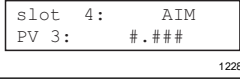
LCD-Anzeige	Anzeige/Funktion
	Menü zur Anzeige der HART PV. Aufruf der Untermenüs durch gleichzeitiges Drücken von ▲ und ▼ .
	Anzeige der konfigurierten PV. Betriebsart 1 = 4 PV, Betriebsart 2 = 8 PV. Wechseln der PV durch Drücken der Taste ▲ oder ▼ .
	Anzeige von "not a number".

### Temperatur Input Modul

Zusätzlich zu den allgemeinen Anzeigen gibt es bei dem Temperatur Input Modul noch die folgende Anzeige:

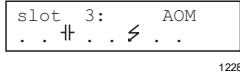
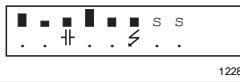
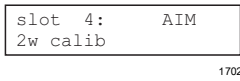
LCD-Anzeige	Anzeige/Funktion
	I/O-Daten. Der Wert für Kanal 0 steht links, der für Kanal 7 rechts. Bei Ausgängen, die noch keine gültigen I/O-Daten erhalten haben, wird die Sicherheitsstellung "s" angezeigt.
	I/O-Fehler. ⚡: Drahtbruch ⚡: Kurzschluss
	I/O-Daten und -Fehler.
	Anzeige Kalibrierung

### 9.1.2 StartUp

Anzeige	Einstellungen						
<div style="border: 1px solid black; padding: 5px; width: fit-content;"> <table style="width: 100%; border-collapse: collapse;"> <tr> <td style="padding: 2px;">FBAdr</td> <td style="padding: 2px;">FB</td> <td style="padding: 2px;">I/O</td> </tr> <tr> <td style="padding: 2px;">120</td> <td style="padding: 2px;">OK</td> <td style="padding: 2px;">OK</td> </tr> </table> </div> <p style="text-align: right; font-size: small;">12258E00</p>	FBAdr	FB	I/O	120	OK	OK	<ul style="list-style-type: none"> <li>Nach Anlegen der Hilfsenergie bootet das Gerät.</li> <li>Nach erfolgreichem Bootvorgang wechselt die LCD-Anzeige in die Systemebene (links dargestellt).</li> </ul>
FBAdr	FB	I/O					
120	OK	OK					

### 9.1.3 Feldbusadresse einstellen

	<p>Die Feldbusadresse kann nur eingestellt werden, wenn sich das Gerät nicht im Zustand Data Exchange befindet.</p>
--	---

Anzeige	Einstellungen						
<div style="border: 1px solid black; padding: 5px; width: fit-content;"> <table style="width: 100%; border-collapse: collapse;"> <tr> <td style="padding: 2px;">FBAdr</td> <td style="padding: 2px;">FB</td> <td style="padding: 2px;">I/O</td> </tr> <tr> <td style="padding: 2px;">120</td> <td style="padding: 2px;">OK</td> <td style="padding: 2px;">OK</td> </tr> </table> </div> <p style="text-align: right; font-size: small;">12258E00</p>	FBAdr	FB	I/O	120	OK	OK	<ul style="list-style-type: none"> <li>Ausgangsanzeige (links dargestellt)</li> </ul>
FBAdr	FB	I/O					
120	OK	OK					
<div style="border: 1px solid black; padding: 5px; width: fit-content;"> <table style="width: 100%; border-collapse: collapse;"> <tr> <td style="padding: 2px;">CPM</td> <td style="padding: 2px;">active</td> </tr> <tr> <td style="padding: 2px;">9440/15-01-11</td> <td></td> </tr> </table> </div> <p style="text-align: right; font-size: small;">12259E00</p>	CPM	active	9440/15-01-11		<ul style="list-style-type: none"> <li>Tasten ▲ und ▼ gleichzeitig drücken. Es erscheint folgende Anzeige (links dargestellt).</li> </ul>		
CPM	active						
9440/15-01-11							
<div style="border: 1px solid black; padding: 5px; width: fit-content;"> <table style="width: 100%; border-collapse: collapse;"> <tr> <td style="padding: 2px;">CPM</td> <td style="padding: 2px;">active</td> </tr> <tr> <td style="padding: 2px;">FB addr :</td> <td style="padding: 2px;">5</td> </tr> </table> </div> <p style="text-align: right; font-size: small;">12260E00</p>	CPM	active	FB addr :	5	<ul style="list-style-type: none"> <li>Tasten ▲ und ▼ gleichzeitig drücken. Es erscheint folgende Anzeige (links dargestellt).</li> </ul>		
CPM	active						
FB addr :	5						
<div style="border: 1px solid black; padding: 5px; width: fit-content;"> <table style="width: 100%; border-collapse: collapse;"> <tr> <td style="padding: 2px;">set FB address</td> </tr> <tr> <td style="padding: 2px;">select: 5</td> </tr> </table> </div> <p style="text-align: right; font-size: small;">12261E00</p>	set FB address	select: 5	<ul style="list-style-type: none"> <li>Tasten ▲ und ▼ gleichzeitig drücken. Es erscheint folgende Anzeige (links dargestellt).</li> </ul>				
set FB address							
select: 5							
<div style="border: 1px solid black; padding: 5px; width: fit-content;"> <table style="width: 100%; border-collapse: collapse;"> <tr> <td style="padding: 2px;">accept changes ?</td> </tr> <tr> <td style="padding: 2px;">yes -&gt; CPM reset</td> </tr> </table> </div> <p style="text-align: right; font-size: small;">12262E00</p>	accept changes ?	yes -> CPM reset	<ul style="list-style-type: none"> <li>Taste ▲ oder ▼ so lange drücken, bis gewünschte Feldbusadresse eingestellt ist. Beim Gedrückthalten der Taste wird der Wert schnell geändert. Der Einstellbereich geht von 0 ... 127.</li> </ul>				
accept changes ?							
yes -> CPM reset							
<div style="border: 1px solid black; padding: 5px; width: fit-content;"> <table style="width: 100%; border-collapse: collapse;"> <tr> <td style="padding: 2px;">accept changes ?</td> </tr> <tr> <td style="padding: 2px;">No</td> </tr> </table> </div> <p style="text-align: right; font-size: small;">12263E00</p>	accept changes ?	No	<ul style="list-style-type: none"> <li>Tasten ▲ und ▼ gleichzeitig drücken. Die Einstellungen werden übernommen. Das Gerät bootet erneut.</li> <li>oder</li> <li>Tasten ▲ oder ▼ drücken. Es erscheint folgende Anzeige (links dargestellt).</li> </ul>				
accept changes ?							
No							
	<ul style="list-style-type: none"> <li>Tasten ▲ und ▼ gleichzeitig drücken. Die Einstellung wird abgebrochen.</li> </ul>						

	<p>Nach dem Einstellen der Feldbusadresse bootet das Gerät erneut. Die Feldbusadresse ist permanent gespeichert und steht auch nach einem Reset oder einer Wiederinbetriebnahme zur Verfügung.</p>
--	--

## 10 Betrieb

### 10.1 Betrieb

Nach Montage, Installation und Inbetriebnahme (siehe Kapitel "Montage und Installation" und "Parametrierung und Inbetriebnahme") ist das CPU & Power Modul betriebsbereit. Weiterführende Dokumentation beachten (Kopplungsbeschreibung).

### 10.2 Anzeigen

Entsprechende LEDs am Gerät zeigen den Betriebszustand des Geräts an (siehe auch Kapitel "Funktion und Geräteaufbau").

LED	Farbe	Bedeutung
LED "RUN"	grün	Betriebsanzeige
LED "ERR"	rot	Anzeige Modulfehler

### 10.3 Fehlerbeseitigung

Bei der Fehlerbeseitigung folgenden Fehlersuchplan beachten:

Fehler	Fehlerursache	Fehlerbehebung
LED "RUN" (grün) leuchtet, LED "ERR" (rot) erloschen	CPM: OK Sammelalarm I/O-Signal	siehe LED-Anzeigen der I/O-Module
LED "RUN" (grün) leuchtet, LED "ERR" (rot) blinkt	CPM: OK, I/O: Modul-Sammelalarm <ul style="list-style-type: none"> <li>• Module gestört</li> <li>• Modul nicht vorhanden</li> <li>• Falsches Modul gesteckt</li> </ul>	<ul style="list-style-type: none"> <li>• Modul tauschen</li> <li>• Modul stecken</li> <li>• Richtiges Modul stecken</li> </ul>
LED "RUN" (grün) blinkt, LED "ERR" (rot) erloschen	In Bereitschaft (nach dem Einschalten, aber noch ohne Datenaustausch mit dem Master)	<ul style="list-style-type: none"> <li>• Zyklischen Datenverkehr mit dem Master in Betrieb setzen.</li> <li>• Master und Busverbindung zu CPM prüfen.</li> </ul>
LED "RUN" (grün) blinkt, LED "ERR" (rot) blinkt	Data Exchange wurde verlassen (Ausgänge in Sicherheitsstellung). Zyklischer Datenverkehr mit dem Master ist unterbrochen.	<ul style="list-style-type: none"> <li>• Zyklischen Datenverkehr mit dem Master in Betrieb setzen.</li> <li>• Master und Busverbindung zu CPM prüfen.</li> </ul>
LED "RUN" (grün) blinkt, LED "ERR" (rot) leuchtet	Konfigurationsfehler. Konfiguration ist nicht in Ordnung	Konfiguration des Masters ändern.
LED "RUN" (grün) erloschen, LED "ERR" (rot) leuchtet/blinkt Anzeige Display: "Supply: fail"	CPM-Hardwarefehler. <ul style="list-style-type: none"> <li>• Hardware-Check-Fehler</li> <li>• Eprom-Fehler</li> <li>• EEprom-Fehler</li> </ul>	CPM tauschen.
LED "RUN" (grün) erloschen, LED "ERR" (rot) erloschen	Keine Versorgungsspannung am CPM vorhanden oder CPM defekt.	<ul style="list-style-type: none"> <li>• Versorgung des CPM prüfen.</li> <li>• CPM prüfen.</li> <li>• BusRail prüfen.</li> <li>• CPM richtig auf BusRail aufrasten.</li> <li>• CPM tauschen.</li> </ul>

Wenn sich der Fehler mit den genannten Vorgehensweisen nicht beheben lässt:

- An R. STAHL Schaltgeräte GmbH wenden.

Zur schnellen Bearbeitung folgende Angaben bereithalten:

- Typ und Seriennummer des Geräts
- DCS/SPS
- Protokoll
- Revisions-Nr/Firmware-Version
- Kaufdaten
- Fehlerbeschreibung
- Einsatzzweck (insbesondere Eingangs-/Ausgangsbeschaltung)

## 11 Instandhaltung, Wartung, Reparatur

### 11.1 Instandhaltung

- Art und Umfang der Prüfungen den entsprechenden nationalen Vorschriften entnehmen.
- Prüfungsintervalle an Betriebsbedingungen anpassen.

Bei der Instandhaltung des Geräts mindestens folgende Punkte prüfen:

- fester Sitz der untergeklebten Leitungen,
- Rissbildung und andere sichtbare Schäden am Gerät,
- Einhaltung der zulässigen Umgebungstemperaturen,
- Bestimmungsgemäße Funktion.

### 11.2 Wartung

Das Gerät benötigt keine regelmäßige Wartung.

	Die geltenden nationalen Bestimmungen im Einsatzland beachten.
---	--

### 11.3 Reparatur

	<b>GEFAHR</b>
	Explosionsgefahr durch unsachgemäße Reparatur! Nichtbeachten führt zu schweren oder tödlichen Verletzungen. <ul style="list-style-type: none"><li>• Reparaturen an den Geräten ausschließlich durch R. STAHL Schaltgeräte GmbH ausführen lassen.</li></ul>



## 11.4 Rücksendung

- Rücksendung bzw. Verpackung der Geräte nur in Absprache mit R. STAHL durchführen! Dazu mit der zuständigen Vertretung von R. STAHL Kontakt aufnehmen.

Für die Rücksendung im Reparatur- bzw. Servicefall steht der Kundenservice von R. STAHL zur Verfügung.

- Kundenservice persönlich kontaktieren.

oder

- Internetseite [r-stahl.com](http://r-stahl.com) aufrufen.
- Unter "Support" > "RMA Formular" > "RMA-Schein anfordern" wählen.
- Formular ausfüllen und absenden.  
Sie erhalten per E-Mail automatisch einen RMA-Schein zugeschickt.  
Bitte drucken Sie diese Datei aus.
- Gerät zusammen mit dem RMA-Schein in der Verpackung an die R. STAHL Schaltgeräte GmbH senden (Adresse siehe Kapitel 1.1).

## 12 Reinigung

- Zur Vermeidung elektrostatischer Aufladung dürfen die Geräte in explosionsgefährdeten Bereichen nur mit einem feuchten Tuch gereinigt werden.
- Bei feuchter Reinigung: Wasser oder milde, nicht scheuernde, nicht kratzende Reinigungsmittel verwenden.
- Keine aggressiven Reinigungsmittel oder Lösungsmittel verwenden.

## 13 Entsorgung

- Nationale und lokal gültige Vorschriften und gesetzliche Bestimmungen zur Entsorgung beachten.
- Materialien getrennt dem Recycling zuführen.
- Umweltgerechte Entsorgung aller Bauteile gemäß den gesetzlichen Bestimmungen sicherstellen.

## 14 Zubehör und Ersatzteile

### HINWEIS

Fehlfunktion oder Geräteschaden durch den Einsatz nicht originaler Bauteile.

Nichtbeachten kann Sachschaden verursachen!

- Nur Original-Zubehör und Original-Ersatzteile der R. STAHL Schaltgeräte GmbH verwenden.



Zubehör und Ersatzteile, siehe Datenblatt auf Homepage [r-stahl.com](http://r-stahl.com).





## CPU & power module for Zone 2/Class I, Div. 2

Series 9440/15



## Contents

1	General Information .....	3
1.1	Manufacturer .....	3
1.2	Information regarding the Operating Instructions.....	3
1.3	Further Documents .....	3
1.4	Conformity with Standards and Regulations.....	3
2	Explanation of Symbols .....	4
2.1	Symbols used in these Operating Instructions.....	4
2.2	Warning Notes .....	4
2.3	Symbols on the Device .....	5
3	Safety Notes .....	5
3.1	Operating Instructions Storage .....	5
3.2	Personnel Qualification .....	5
3.3	Safe Use .....	6
3.4	Modifications and Alterations .....	7
4	Function and Device Design .....	7
4.1	Function .....	8
4.2	Device Design.....	8
5	Technical Data.....	9
6	Project Engineering.....	13
6.1	Terminal Assignment of pluggable Terminal X5 .....	13
6.2	Terminal Assignment of Sub-D Sockets X1, X2 and X3 .....	13
7	Transport and Storage.....	14
8	Mounting and Installation .....	14
8.1	Dimensions/Fastening Dimensions.....	14
8.2	Mounting/Dismounting, Operating Position.....	15
8.3	Installation.....	16
9	Parameterisation and Commissioning .....	17
9.1	Parameterisation.....	17
10	Operation .....	23
10.1	Operation .....	23
10.2	Indicators .....	23
10.3	Troubleshooting .....	23
11	Maintenance, Overhaul, Repair .....	24
11.1	Maintenance .....	24
11.2	Overhaul .....	24
11.3	Repair .....	24
11.4	Returning the Device .....	25
12	Cleaning.....	25
13	Disposal .....	25
14	Accessories and Spare Parts.....	25

# 1 General Information

## 1.1 Manufacturer

R. STAHL Schaltgeräte GmbH  
Am Bahnhof 30  
74638 Waldenburg  
Germany

Tel.: +49 7942 943-0  
Fax: +49 7942 943-4333  
Internet: r-stahl.com  
E-mail: info@r-stahl.com

## 1.2 Information regarding the Operating Instructions

ID no.: 162278 / 9440609310  
Publication code: 2024-03-07-BA00-III-en-09

The original instructions are the German edition.  
They are legally binding in all legal affairs.

## 1.3 Further Documents

- IS1+ coupling description (download from r-stahl.com)
- Data sheet
- National information and documents relating to use in hazardous areas (see also chapter 1.4)

For documents in other languages, see r-stahl.com.

## 1.4 Conformity with Standards and Regulations

IECEX, ATEX, EU Declaration of Conformity and further national certificates and documents can be downloaded via the following link:



<https://r-stahl.com/en/global/support/downloads/>

Depending on the scope of validity, additional Ex-relevant information may be attached.

IECEX is also available at: <https://www.iecex.com/>

## 2 Explanation of Symbols



### 2.1 Symbols used in these Operating Instructions

Symbol	Meaning
	Tips and recommendations on the use of the device
	Explosive atmosphere hazard



### 2.2 Warning Notes

Warning notes must be observed under all circumstances, in order to minimise the risk resulting from design engineering and operation. The warning notes have the following structure:

- Signalling word: DANGER, WARNING, CAUTION, NOTICE
- Type and source of danger/damage
- Consequences of danger
- Taking countermeasures to avoid the danger or damage

	<b>DANGER</b>
	Danger to persons Non-compliance with the instruction results in severe or fatal injuries to persons.
	<b>WARNING</b>
	Danger to persons Non-compliance with the instruction can result in severe or fatal injuries to persons.
	<b>CAUTION</b>
	Danger to persons Non-compliance with the instruction can result in light injuries to persons.
<b>NOTICE</b>	
Avoiding material damage Non-compliance with these instructions can result in material damage to the device and/or its surroundings.	

## 2.3 Symbols on the Device

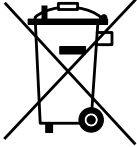
Symbol	Meaning
 05594E00	CE marking according to the current applicable directive.
 02198E00	Electrical circuit certified for hazardous areas according to the marking.
 11048E00	Safety notes that must always be observed: The corresponding data and/or safety-related instructions contained in the operating instructions must be followed for devices with this symbol!
 20690E00	Marking according to WEEE Directive 2012/19/EU

## 3 Safety Notes

### 3.1 Operating Instructions Storage

- Carefully read the operating instructions.
- Store the operating instructions at the mounting location of the device.
- Observe applicable documents and operating instructions of the devices to be connected.

### 3.2 Personnel Qualification

Qualified specialist personnel is required to perform the activities described in these operating instructions. This primarily applies to work in the following areas

- Project engineering
- Mounting/dismounting the device
- (Electrical) installation
- Commissioning
- Maintenance, repair, cleaning

Specialists who perform these activities must have a level of knowledge that meets applicable national standards and regulations.

Additional knowledge is required for any activity in hazardous areas.

R. STAHL recommends having a level of knowledge equal to that described in the following standards:

- IEC/EN 60079-14 (Electrical installations design, selection and erection)
- IEC/EN 60079-17 (Electrical installations inspection and maintenance)
- IEC/EN 60079-19 (Equipment repair, overhaul and reclamation)

### 3.3 Safe Use

#### Before mounting

- Read and observe the safety notes in these operating instructions!
- Ensure that the contents of these operating instructions are fully understood by the personnel in charge.
- Use the device in accordance with its intended and approved purpose only.
- Always consult R. STAHL Schaltgeräte GmbH if using the device under operating conditions which are not covered by the technical data.
- Make sure that the device is not damaged.
- We cannot be held liable for damage to the device caused by incorrect or impermissible use or non-compliance with these operating instructions.

#### For mounting and installation



- Have mounting and installation performed only by qualified and authorised persons (see chapter "Personnel qualification").
- The device is only to be installed in areas for which it is suited based on its marking.
- During installation and operation, observe the information (characteristic values and rated operating conditions) on the rating, data and information plates located on the device.
- Before installation, make sure that the device is not damaged.
- When used in Zone 2, the device must be installed in a protective enclosure or in a cabinet according to IEC/EN 60079-0. This enclosure (or cabinet) must have a suitable degree of protection (at least IP54).
- When used in Zone 22, the device must be installed in a protective enclosure or in a cabinet according to IEC/EN 60079-31. This enclosure (or cabinet) must have a suitable degree of protection (at least IP64).
- When used in Zone 22, the system may only be installed in an enclosure that has been approved for areas with dust (protected by enclosure). The electrician must ensure that the requirements of IEC/EN 60079-31 are met, e.g. with regard to dust deposits and permissible temperature.
- Consider and calculate the heat build-up in the enclosure.
- When used in Class I, Division 2, install the device according to the control drawing.
- When used in safe areas, install the device in an environment with a degree of pollution of 1 or 2 according to IEC/EN 60664-1 and an overvoltage category of I, II or III.
- When operated together with Ex i electrical circuits, protect the non-intrinsically safe terminals with a cover that fulfils the IP30 degree of protection. If the cover is missing: Only open the enclosure when the device is de-energised.
- The module may only be installed in a vertical or horizontal position and only on the 9494 BusRail.
- Connect the DIN rail of the 9494 BusRail to the equipotential bonding.



**Commissioning, maintenance, repair**

- Only have commissioning and repairs performed by qualified and authorised persons (see chapter "Personnel qualification").
- Before commissioning, make sure that the device is not damaged.
- Only perform the maintenance work described in these operating instructions.
- To prevent electrostatic charge, only clean the device with a damp cloth.
- Before dismounting or replacing the module in an explosive atmosphere, ensure that the auxiliary power is disconnected.

**3.4 Modifications and Alterations**

	<p style="text-align: center;"><b>DANGER</b></p> <p>Explosion hazard due to modifications and alterations to the device! Non-compliance results in severe or fatal injuries.</p> <ul style="list-style-type: none"> <li>• Do not modify or change the device.</li> </ul>
	<p>No liability or warranty for damage resulting from modifications and alterations.</p>

**4 Function and Device Design**

	<p style="text-align: center;"><b>DANGER</b></p> <p>Explosion hazard due to improper use! Non-compliance results in severe or fatal injuries.</p> <ul style="list-style-type: none"> <li>• Use the device only according to the operating conditions described in these operating instructions.</li> <li>• Use the device only for the intended purpose specified in these operating instructions.</li> </ul>
---	---

### 4.1 Function

The 9440/15 CPU & power module fulfils the function of a gateway between the internal bus of an IS1+ field station and the fieldbus which connects the field station singly or redundantly to the automation system.

#### Application range

The device is designed for IS1+ field stations and may be installed in hazardous areas of Zone 2/Class I, Div. 2 or Zone 22.

#### Power supply and communication

The module contains a power supply unit for its own power supply and also for the power supply to the I/O modules and field circuits. The I/O modules are supplied with power via the BusRail. When using a redundant CPU & power module, the power supply to the I/O modules is internally decoupled with diodes. The power supply unit is fitted with undervoltage monitoring.

Communication with the I/O modules takes place via the address and data lines on the BusRail. The interface between the CPU & power module and the internal data bus on the BusRail is designed to be redundant.

### 4.2 Device Design

	#	Device element	Description
	1	Cover flap	Cover flap with insert disc and connection diagram (open)
	2	LCD display	For displaying diagnostic data, input and output values
	3	Labelling	Module data (serial number, hardware revision number, software revision number, date of manufacture, e.g.: 123456DE9999 Rev. A 01-01 0508)
	4	Buttons	<down>, <up> buttons
	5	Notch lever	Notch lever for removing the module from the BusRail
	6	LED	LED for indication of operation ("RUN", green) and error ("ERR", red) (for further information, see the "Indicators" chapter)
	7	Sub-D socket X1	Process bus, primary
	8	Sub-D socket X2	Process bus, redundant (can only be used with PROFIBUS DP)
	9	Sub-D socket X3	Service bus
	10	Terminal X5	Auxiliary power, pluggable terminal with two safety screws

## 5 Technical Data

### Explosion protection

#### Global (IECEX)

Gas	IECEX PTB 14.0039X Ex ec [ia Ga] [ib Gb] IIC T4 Gc
-----	---

#### Europe (ATEX, UKEX)

Gas	PTB 99 ATEX 2222 ⊕ II 3 (2) G Ex ec [ia Ga] [ib Gb] IIC T4 Gc
-----	--

### Certifications and certificates

Certificates	IECEX, ATEX, cFMus (Canada, USA), CCC (China), KTL (South Korea), INMETRO (Brazil)
Ship certificates	EU RO Mutual Recognition (incl. ABS, BV, CCS, CRS, DNV GL, IRS, KR, LR, ClassNK, PRS, RINA, RS)

### Further parameters

Installation in	Zone 2/Class I, Div. 2 and in safe areas
Further information	See relevant certificate and operating instructions

### Technical data

#### Electrical data

Auxiliary power	
Nominal voltage	24 V DC
Voltage range	20 to 35 V DC
Current consumption	
without I/O modules	0.3 A at 24 V
with 8 I/O modules	approx. 2.5 A at 24 V
with 16 I/O modules	approx. 4.9 A at 24 V
Power dissipation	
without I/O modules	7.2 W
per I/O module	approx. 1 W
Polarity reversal protection	Yes
Undervoltage monitoring	Yes

**Technical data**

Fieldbus, redundant fieldbus and service bus interfaces	
Interface	RS485
Conductor length/ transfer rate	
Copper cable	1200 m at 9.6 to 93.75 kbps 1000 m at 187.5 kbps 400 m at 500 kbps 200 m at 1.5 Mbps
Note	FO technology is available for longer lengths
Fibre optic	approx. 2000 m at 1.5 Mbps
Service bus	1200 m at 9.6 kbps
Line termination	according to fieldbus standard
Address setting	0 to 127
Redundancy	System redundancy
PROFIBUS DP	
Versions	DP V0, DP V1, DP V1 HART
Transmission rate	9.6 kbps to 1.5 Mbps
Data transmission	approx. 40 16-bit words/ms (cyclically, net at 1.5 Mbps)
Modbus RTU	
Transmission rate	9.6 to 38.4 kbps
Data transmission	approx. 1000 16-bit register/s (at 38.4 kbps)
Functions	Read, write; see Modbus RTU coupling description
Characteristic values	
Max. internal signal delay with 8 I/O modules (without module delay)	
for digital modules	7 ms
for analogue modules	10 ms
Operator interface	
Software	IS1+ DTM devices or IS Wizard
Operation	"RUN" LED, green
Error	"ERR" LED, red
LCD display	2 x 16 characters
Settings	Bus address
Displays	Bus address, alarms/errors, information (type, revision, etc.) for the levels of field station, modules and signals, and values for inputs and outputs

**Technical data**

Diagnostics and parameterisation	
Functions	<ul style="list-style-type: none"> <li>• Load or read back configuration data and parameters in IS1+ field stations</li> <li>• Read inputs</li> <li>• Read and write outputs</li> <li>• Transmit diagnostics data (e.g. configuration error, hardware error, signal error)</li> <li>• Transmit HART commands from/to HART field devices</li> </ul>
Connectable software packages	<ul style="list-style-type: none"> <li>• IS Wizard (using R. STAHL service bus)</li> <li>• R. STAHL DTM</li> <li>• AMS from Emerson Process Management</li> <li>• PDM from Siemens</li> <li>• PRM and FieldMate from Yokogawa</li> <li>• FieldCare from Endress + Hauser</li> <li>• FDM from Honeywell</li> <li>• etc.</li> </ul>
Power supply for I/O modules via the BusRail	
Voltage range	22.5 to 26.2 V DC
Max. current	4 A
Max. number of I/O modules	16
Redundant supply for the I/O modules	Yes
Undervoltage monitoring	Yes
Galvanic separation	
between auxiliary power and system components	1500 V AC
between fieldbus/ service bus interface and system components	1500 V AC
between two bus interfaces	500 V AC
Electromagnetic compatibility	Tested in accordance with the following standards and regulations: EN 61326-1, EN 61000-4-1 to 6, NAMUR NE 21

**Technical data**

**Ambient conditions**

Ambient temperature	-20 to +65 °C
Storage temperature	-40 to +70 °C
Relative humidity (no condensation)	< 95%
For use at a height of	< 2000 m
Semi-sinusoidal shock (IEC/EN 60068-2-27)	15 g (3 shocks per axis and direction)
Vibration, sinusoidal (IEC/EN 60068-2-6)	1 g in the frequency range of 10 to 500 Hz 2 g in the frequency range of 45 to 100 Hz

**Mechanical data**

Connection	
Fieldbus RS485	9-pole Sub-D socket
RS485 service bus	9-pole Sub-D socket
Auxiliary power	Pluggable screw terminals with lock, 4.0 mm <sup>2</sup>
Degree of protection (IEC 60529)	
Modules	IP30
Connections	IP20
Module enclosure	Polyamide 6GF
Fire resistance (UL 94)	V2

**Mounting/installation**

Installation conditions	
Mounting type	on 35 mm DIN rail NS 35/15
Mounting orientation	horizontal and vertical

For further technical data, see [r-stahl.com](http://r-stahl.com).

## 6 Project Engineering

### NOTICE

An ambient temperature that is too high may cause failure of the devices installed in the cabinet.

Non-compliance can result in material damage.

- Install and set up the cabinet in such a way that all devices installed within it are always operated within their permissible temperature range.

The following conditions must be observed during project engineering:

- To ensure adherence with the intended use, only install the device on the IS1+ 9494 BusRail.
- Operation of the device is only permissible in three approved mounting positions: See the "Mounting/dismounting on BusRail" chapter.
- Up to 16 I/O modules can be operated using the device. If only analogue modules are used, up to 15 I/O modules can be operated.
- The primary device must be installed on the first slot of the 9494 BusRail.
- The redundant device (optional) must be installed on the second slot of the 9494 BusRail.
- The DIN rail of the 9494 BusRail must be connected to the equipotential bonding of the hazardous area.
- Work on the connected auxiliary power electrical circuits is permitted only if they are de-energised.

### 6.1 Terminal Assignment of pluggable Terminal X5

The auxiliary power is connected to the CPM module via pluggable terminal X5 (included in the module scope of delivery).

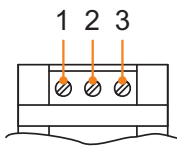
	Function	Terminal no.
 <small>12227E00</small>	+24 V DC	1
	0 V	2
	no conductor connection	3

### 6.2 Terminal Assignment of Sub-D Sockets X1, X2 and X3

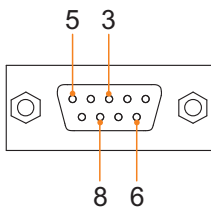
	Pin no.	Function	Description
 <small>12224E00</small>	3	RxD/TxD (+)	Data B (+)
	5	GND	Reference potential for device interface
	6	5 V (+)	Supply voltage (device)
	8	RxD/TxD (-)	Data A (-)
	Remaining pins	–	not connected

## 7 Transport and Storage

- Transport and store the device only in the original packaging.
- Store the device in a dry place (no condensation) free of vibrations.
- Do not drop the device.

## 8 Mounting and Installation

The device is approved for use in gas hazardous areas of Zone 2, in dust hazardous areas of Zone 22 and in safe areas.

	DANGER
<p>Explosion hazard due to incorrect installation of the device! Non-compliance results in severe or fatal injuries.</p> <ul style="list-style-type: none"> <li>• Carry out installation strictly according to the instructions and national safety and accident prevention regulations to maintain explosion protection.</li> <li>• Select and install the electrical device so that explosion protection is not affected due to external influences, i.e. pressure conditions, chemical, mechanical, thermal and electrical influences such as vibration, humidity and corrosion (see IEC/EN 60079-14).</li> <li>• The device must only be installed by trained qualified personnel who are familiar with the relevant standards.</li> </ul>	

### 8.1 Dimensions/Fastening Dimensions

Dimensional drawings (all dimensions in mm [inch]) – Subject to change

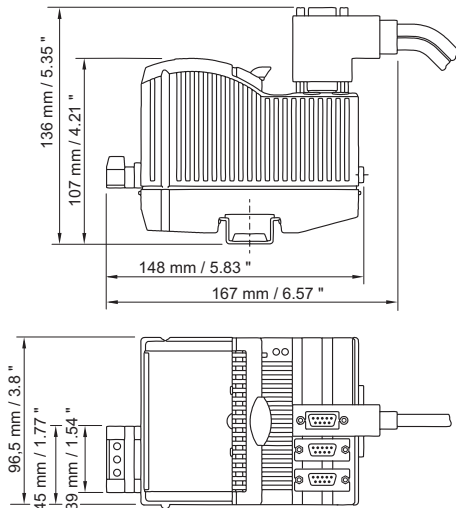

09878E00



## 8.2 Mounting/Dismounting, Operating Position

### 8.2.1 Mounting/Dismounting

#### NOTICE

Malfunction or device damage caused by improper mounting.

Non-compliance may lead to material damage.

- The device must only ever be mounted vertically, with the reading direction of the LCD display either from below, the left or the right.

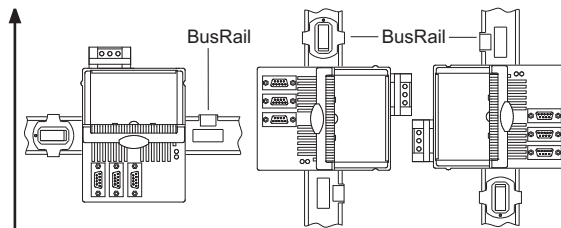

12228E00

#### Mounting on BusRail

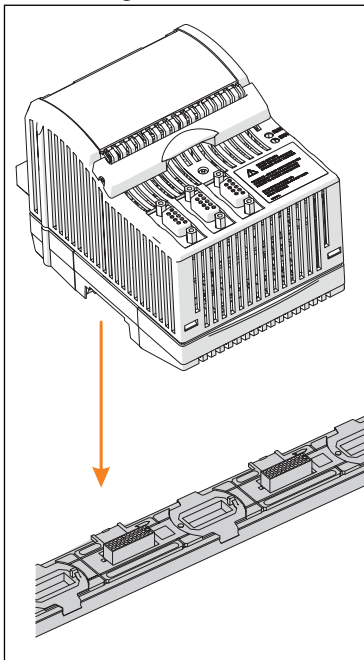

22319E00

- Position the module vertically on the first slot of the BusRail and press down on it slightly to snap it into place.
- Press the module down onto the BusRail on the left and right again to ensure that it is properly secured. There should not be a gap between the module and BusRail. The module must no longer come loose without the notch lever being actuated.
- Plug pluggable terminal X5 into the module and secure it with safety screws so that it cannot come loose (tightening torque 0.5 to 0.6 Nm).

## 8.2.2 Requirements for Dismounting/Module Replacement

Observe the following before dismounting or replacing the module:

- Disconnect the auxiliary power.

### Dismounting

- Loosen the screws of the pluggable terminal X5.
- Disconnect pluggable terminal X5 from the module to be replaced.
- Remove the fieldbus connections from the Sub-D sockets.
- Pull the blue notch lever of the module upwards to unlock the module.
- Remove the module vertically from the BusRail.

### Module replacement (after dismounting)

- Position the new module vertically at the intended slot of the BusRail and press lightly to snap it into place.
- Press the module down onto the BusRail on the left and right again to ensure that it is properly secured.

When doing this, check that there is no gap between the module and BusRail.

The module must no longer come loose without the notch lever being actuated.

- Connect the fieldbuses to the Sub-D sockets again.
- Plug pluggable terminal X5 into the module and secure it with screws so that it cannot come loose (tightening torque 0.5 to 0.6 Nm).

## 8.3 Installation



Operation under difficult conditions, e.g. on ships in particular, requires additional measures to be taken for correct installation, depending on the operating location. Further information and instructions on this can be obtained on request from your designated sales contact.

### 8.3.1 Connecting the Auxiliary Power

- Connect the auxiliary power to terminal X5 (see chapter 6.1).  
The nominal voltage of auxiliary power is 24 V DC (see data sheet).
- Secure the pluggable terminal on the CPU & power module with screws so that it cannot come loose (tightening torque 0.5 to 0.6 Nm)

### 8.3.2 Connecting the Fieldbus

- Connect the primary fieldbus to Sub-D socket X1.
- If necessary, connect a redundant fieldbus to Sub-D socket X2 (only possible with PROFIBUS DP).
- Secure the Sub-D connector with screws so that it cannot come loose (tightening torque 0.5 to 0.6 Nm).

### 8.3.3 Connecting the Service Bus

- Connect the service bus to Sub-D socket X3.
- Secure the Sub-D connector with screws so that it cannot come loose (tightening torque 0.5 to 0.6 Nm).

## 9 Parameterisation and Commissioning

	DANGER
	<p>Explosion hazard due to incorrect installation! Non-compliance results in severe or fatal injuries.</p> <ul style="list-style-type: none"> <li>• Check the device for proper installation before commissioning.</li> <li>• Comply with national regulations.</li> </ul>

Before commissioning, ensure the following:

- The device has been installed according to regulations.
- The electrical lines are connected correctly.
- The device and connection lines show no signs of damage.
- The screws are securely fastened to the terminals.  
Correct tightening torque: 0.5 to 0.6 Nm.

### 9.1 Parameterisation

The CPM and the connected I/O modules are parameterised and commissioned using the automation system and the service bus (optional).

Only the fieldbus address of the CPM must be set directly at the module.

The buttons of the LCD display can be used

- to set the fieldbus address of the device
- Display information about the device and the I/O modules installed on the BusRail (see the "Indicators" chapter).

#### 9.1.1 LCD Displays

##### Switch to a specific module display

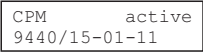
LCD display	Settings
 12258E00	<ul style="list-style-type: none"> <li>• Initial display (shown on the left)</li> </ul>
 12259E00	<ul style="list-style-type: none"> <li>• Press the ▲ and ▼ buttons simultaneously to switch from the system level to the module level. The following display appears (shown on the left).</li> <li>• Press the ▲ or ▼ button to select the required module.</li> </ul>
	<ul style="list-style-type: none"> <li>• Press the ▲ and ▼ buttons simultaneously. The display switches to the information level.</li> <li>• Press the ▲ or ▼ button to switch between different LCD displays (see following table).</li> </ul>

### Display of the CPM status information

LCD display	Display/function																				
<div style="border: 1px solid black; padding: 5px; width: fit-content;">                     CPM      active                      FB addr : 5                 </div> <p style="font-size: small; margin-top: 5px;">12260E00</p>	Status and fieldbus address of the device.																				
<div style="border: 1px solid black; padding: 5px; width: fit-content;">                     CPM information                      Modbus    V10-00                 </div> <p style="font-size: small; margin-top: 5px;">12264E00</p>	Type of coupling																				
<div style="border: 1px solid black; padding: 5px; width: fit-content;">                     CPM      status                      config/para fail                 </div> <p style="font-size: small; margin-top: 5px;">12265E00</p>	Status of the device.  Possible status information: <table border="1" style="width: 100%; border-collapse: collapse;"> <thead> <tr> <th>Status information on the LCD display</th> <th>Meaning</th> </tr> </thead> <tbody> <tr> <td>no error</td> <td>there are no errors</td> </tr> <tr> <td>hardware fail (1)</td> <td>Hardware error detected</td> </tr> <tr> <td>hardware fail (2)</td> <td>wrong hardware identification</td> </tr> <tr> <td>hardware fail (3)</td> <td>no communication between CPR and IOP</td> </tr> <tr> <td>DataExch AS</td> <td>Data exchange with automation system, configuration via PROFIBUS</td> </tr> <tr> <td>DataExch AS (2)</td> <td>Data exchange with automation system</td> </tr> <tr> <td>no DataExch</td> <td>no data exchange</td> </tr> <tr> <td>config/para fail</td> <td>Configuration or parameter error</td> </tr> <tr> <td>quit DataExch</td> <td>no more data exchange</td> </tr> </tbody> </table>	Status information on the LCD display	Meaning	no error	there are no errors	hardware fail (1)	Hardware error detected	hardware fail (2)	wrong hardware identification	hardware fail (3)	no communication between CPR and IOP	DataExch AS	Data exchange with automation system, configuration via PROFIBUS	DataExch AS (2)	Data exchange with automation system	no DataExch	no data exchange	config/para fail	Configuration or parameter error	quit DataExch	no more data exchange
Status information on the LCD display	Meaning																				
no error	there are no errors																				
hardware fail (1)	Hardware error detected																				
hardware fail (2)	wrong hardware identification																				
hardware fail (3)	no communication between CPR and IOP																				
DataExch AS	Data exchange with automation system, configuration via PROFIBUS																				
DataExch AS (2)	Data exchange with automation system																				
no DataExch	no data exchange																				
config/para fail	Configuration or parameter error																				
quit DataExch	no more data exchange																				
<div style="border: 1px solid black; padding: 5px; width: fit-content;">                     CPM      active                      back                 </div> <p style="font-size: small; margin-top: 5px;">12266E00</p>	Press the ▲ and ▼ buttons simultaneously. Switch back to the module level of the device.																				
<div style="border: 1px solid black; padding: 5px; width: fit-content;">                     CPM      active                      exit menu                 </div> <p style="font-size: small; margin-top: 5px;">12267E00</p>	Press the ▲ and ▼ buttons simultaneously. Switch back to the main display of the device.																				

### Switch to a specific module display

LCD display	Settings
<div style="border: 1px solid black; padding: 5px; width: fit-content;">                     FBAdr    FB    I/O                      120      OK    OK                 </div> <p style="font-size: small; margin-top: 5px;">12258E00</p>	<ul style="list-style-type: none"> <li>Initial display (shown on the left)</li> </ul>
<div style="border: 1px solid black; padding: 5px; width: fit-content;">                     CPM      active                      9440/15-01-11                 </div> <p style="font-size: small; margin-top: 5px;">12259E00</p>	<ul style="list-style-type: none"> <li>Press the ▲ and ▼ buttons to switch from the system level to the module level. The following display appears (shown on the left).</li> <li>Press the ▲ or ▼ button to select the required module.</li> </ul>
	<ul style="list-style-type: none"> <li>Press the ▲ and ▼ buttons simultaneously. The display switches to the information level/service level.</li> </ul>

### Display of the I/O module status information

<b>i</b>	The following displays have the same structure for all I/O modules.
----------	---

LCD display	Display/function																								
<div style="border: 1px solid black; padding: 2px; margin-bottom: 5px;">                     slot 2: AOM                      module OK/mode:0                 </div> <p style="font-size: small; margin: 0;">12268E00</p>	<p>Display of the slot, module type and module status.</p> <p>Possible module statuses:</p> <table border="1" style="width: 100%; border-collapse: collapse;"> <thead> <tr> <th style="width: 40%;">Status information on the LCD display</th> <th style="width: 40%;">Meaning</th> <th style="width: 20%;">Priority</th> </tr> </thead> <tbody> <tr> <td>IOM no response</td> <td>Communication with the module is not possible. The module is defective or not inserted, or both BusRails and/or the BusRail connecting line are faulty</td> <td style="text-align: center;">1</td> </tr> <tr> <td>hardware failure</td> <td>The module reports a hardware error</td> <td style="text-align: center;">2</td> </tr> <tr> <td>conf unequal mod</td> <td>Configuration error or incorrect module inserted</td> <td style="text-align: center;">3</td> </tr> <tr> <td>HW disable outp.</td> <td>Outputs disconnected by an external switch (Plant STOP) (only with DOM 9475/2)</td> <td style="text-align: center;">4</td> </tr> <tr> <td>prim. Rail fail</td> <td>no communication via primary BusRail data bus</td> <td style="text-align: center;">5</td> </tr> <tr> <td>red. Rail fail</td> <td>no communication via redundant BusRail data bus</td> <td style="text-align: center;">5</td> </tr> <tr> <td>module OK/mode: x</td> <td>Module is OK. No module error. Signal errors are still possible. The configured operating mode (mode:x) is also displayed</td> <td style="text-align: center;">6</td> </tr> </tbody> </table> <p>If there are multiple errors, only the error with the highest priority is displayed. Once this error has been eliminated, the error with the next highest priority is displayed.</p>	Status information on the LCD display	Meaning	Priority	IOM no response	Communication with the module is not possible. The module is defective or not inserted, or both BusRails and/or the BusRail connecting line are faulty	1	hardware failure	The module reports a hardware error	2	conf unequal mod	Configuration error or incorrect module inserted	3	HW disable outp.	Outputs disconnected by an external switch (Plant STOP) (only with DOM 9475/2)	4	prim. Rail fail	no communication via primary BusRail data bus	5	red. Rail fail	no communication via redundant BusRail data bus	5	module OK/mode: x	Module is OK. No module error. Signal errors are still possible. The configured operating mode (mode:x) is also displayed	6
Status information on the LCD display	Meaning	Priority																							
IOM no response	Communication with the module is not possible. The module is defective or not inserted, or both BusRails and/or the BusRail connecting line are faulty	1																							
hardware failure	The module reports a hardware error	2																							
conf unequal mod	Configuration error or incorrect module inserted	3																							
HW disable outp.	Outputs disconnected by an external switch (Plant STOP) (only with DOM 9475/2)	4																							
prim. Rail fail	no communication via primary BusRail data bus	5																							
red. Rail fail	no communication via redundant BusRail data bus	5																							
module OK/mode: x	Module is OK. No module error. Signal errors are still possible. The configured operating mode (mode:x) is also displayed	6																							
<div style="border: 1px solid black; padding: 2px; margin-bottom: 5px;">                     slot 1: AOM                      FW 02-04, HW 'E'                 </div> <p style="font-size: small; margin: 0;">12269E00</p>	<p>Display of the firmware and hardware revision.</p>																								
<div style="border: 1px solid black; padding: 2px; margin-bottom: 5px;">                     slot 3: AOM                      SNo: 123456-7890                 </div> <p style="font-size: small; margin: 0;">12270E00</p>	<p>Display of the serial number.</p>																								

### Digital module

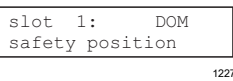
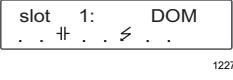
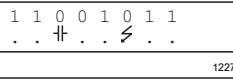
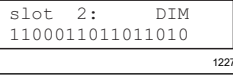
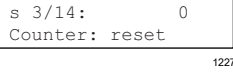
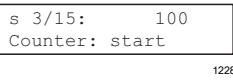

In addition to the general displays, digital modules also have the following displays:

LCD display	Display/function
 <p>slot 1: DOM safety position</p> <p>12272E00</p>	In the absence of output data, the safety status of the outputs is displayed. (only for output modules)
 <p>slot 1: DOM ⚡ ⚡ ⚡ ⚡</p> <p>12273E00</p>	I/O error. ⚡: Wire breakage ⚡: Short circuit
 <p>1 1 0 0 1 0 1 1 ⚡ ⚡ ⚡ ⚡</p> <p>12274E00</p>	I/O data and error.
 <p>slot 2: DIM 1100011011011010</p> <p>12276E00</p>	I/O data. The value for channel 0 is displayed on the left, for channel 15 on the right.
 <p>s 3/14: 0 Counter: reset</p> <p>12279E00</p>	Display of the counter value/frequency value and of the "start" and "reset" control bits for channel 14. (only for input module)
 <p>s 3/15: 100 Counter: start</p> <p>12280E00</p>	Display of the counter value/frequency value and of the "start" and "reset" control bits for channel 15. (only for input module)

### Analogue module

In addition to the general displays, the analogue module also has the following displays, see table.

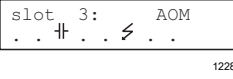
When using HART for module 9468, there are additional menu items (see "Analogue module with HART")

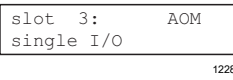
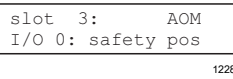
LCD display	Display/function
 <p>slot 3: AOM ■ ■ ■ ■ ■ s s</p> <p>12281E00</p>	I/O data. The value for channel 0 is displayed on the left, for channel 7 on the right. For outputs that have not yet received any valid I/O data, the safety position "s" is displayed.
 <p>slot 3: AOM ⚡ ⚡ ⚡ ⚡</p> <p>12282E00</p>	I/O error. ⚡: Wire breakage ⚡: Short circuit
 <p>■ ■ ■ ■ ■ s s ⚡ ⚡ ⚡ ⚡</p> <p>12283E00</p>	I/O data and error.
 <p>slot 3: AOM single I/O</p> <p>12284E00</p>	Display of the I/O data for individual channels. Press the ▲ and ▼ buttons simultaneously to access the submenu.
 <p>slot 3: AOM I/O 0: safety pos</p> <p>12285E00</p>	Display of I/O errors or I/O data. If no I/O value is available, the safety position is displayed. Press the ▲ and ▼ buttons simultaneously to switch between channels.

## Analogue module with HART

The HART PVs can be displayed for HART module 9468.

The submenu is only displayed if the analogue modules are configured to transmit HART PVs.

Only configured HART PVs are displayed.

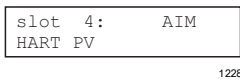
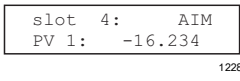
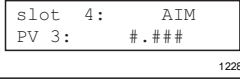
LCD display	Display/function
	Menu for displaying the HART PVs. Press ▲ and ▼ simultaneously to access the submenu.
	Display of the configured PVs. Operating mode 1 = 4 PVs, operating mode 2 = 8 PVs. Press the ▲ or ▼ button to change the PVs.
	Display of "not a number".

## Temperature Input Module

In addition to the general displays, the Temperature Input Module also has the following displays:

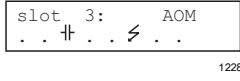
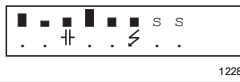
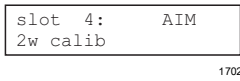
LCD display	Display/function
	I/O data. The value for channel 0 is displayed on the left, for channel 7 on the right. For outputs that have not yet received any valid I/O data, the safety position "s" is displayed.
	I/O error. ‡: Wire breakage ⚡: Short circuit
	I/O data and error.
	Display of calibration

### 9.1.2 Start-up

Display	Settings						
<div style="border: 1px solid black; padding: 5px; width: fit-content;"> <table style="width: 100%; border-collapse: collapse;"> <tr> <td style="padding: 2px;">FBAdr</td> <td style="padding: 2px;">FB</td> <td style="padding: 2px;">I/O</td> </tr> <tr> <td style="padding: 2px;">120</td> <td style="padding: 2px;">OK</td> <td style="padding: 2px;">OK</td> </tr> </table> <p style="text-align: right; font-size: small; margin-top: 5px;">12258E00</p> </div>	FBAdr	FB	I/O	120	OK	OK	<ul style="list-style-type: none"> <li>• After connecting the auxiliary power, the device will boot.</li> <li>• After successful completion of the booting process, the LCD display switches to the system level (shown on the left).</li> </ul>
FBAdr	FB	I/O					
120	OK	OK					

### 9.1.3 Setting the Fieldbus Address

	<p>The fieldbus address can only be set if the device is not in Data Exchange mode.</p>
---	---

Display	Settings						
<div style="border: 1px solid black; padding: 5px; width: fit-content;"> <table style="width: 100%; border-collapse: collapse;"> <tr> <td style="padding: 2px;">FBAdr</td> <td style="padding: 2px;">FB</td> <td style="padding: 2px;">I/O</td> </tr> <tr> <td style="padding: 2px;">120</td> <td style="padding: 2px;">OK</td> <td style="padding: 2px;">OK</td> </tr> </table> <p style="text-align: right; font-size: small; margin-top: 5px;">12258E00</p> </div>	FBAdr	FB	I/O	120	OK	OK	<ul style="list-style-type: none"> <li>• Initial display (shown on the left)</li> </ul>
FBAdr	FB	I/O					
120	OK	OK					
<div style="border: 1px solid black; padding: 5px; width: fit-content;"> <table style="width: 100%; border-collapse: collapse;"> <tr> <td style="padding: 2px;">CPM</td> <td style="padding: 2px;">active</td> </tr> <tr> <td style="padding: 2px;">9440/15-01-11</td> <td></td> </tr> </table> <p style="text-align: right; font-size: small; margin-top: 5px;">12259E00</p> </div>	CPM	active	9440/15-01-11		<ul style="list-style-type: none"> <li>• Press the ▲ and ▼ buttons simultaneously. The following display appears (shown on the left).</li> </ul>		
CPM	active						
9440/15-01-11							
<div style="border: 1px solid black; padding: 5px; width: fit-content;"> <table style="width: 100%; border-collapse: collapse;"> <tr> <td style="padding: 2px;">CPM</td> <td style="padding: 2px;">active</td> </tr> <tr> <td style="padding: 2px;">FB addr :</td> <td style="padding: 2px;">5</td> </tr> </table> <p style="text-align: right; font-size: small; margin-top: 5px;">12260E00</p> </div>	CPM	active	FB addr :	5	<ul style="list-style-type: none"> <li>• Press the ▲ and ▼ buttons simultaneously. The following display appears (shown on the left).</li> </ul>		
CPM	active						
FB addr :	5						
<div style="border: 1px solid black; padding: 5px; width: fit-content;"> <table style="width: 100%; border-collapse: collapse;"> <tr> <td style="padding: 2px;">set FB address</td> </tr> <tr> <td style="padding: 2px;">select: 5</td> </tr> </table> <p style="text-align: right; font-size: small; margin-top: 5px;">12261E00</p> </div>	set FB address	select: 5	<ul style="list-style-type: none"> <li>• Press the ▲ and ▼ buttons simultaneously. The following display appears (shown on the left).</li> </ul>				
set FB address							
select: 5							
	<ul style="list-style-type: none"> <li>• Press the ▲ or ▼ button until the required fieldbus address has been set. Pressing and holding the button changes the value quickly. The adjustment range goes from 0 to 127.</li> </ul>						
<div style="border: 1px solid black; padding: 5px; width: fit-content;"> <table style="width: 100%; border-collapse: collapse;"> <tr> <td style="padding: 2px;">accept changes ?</td> </tr> <tr> <td style="padding: 2px;">yes -&gt; CPM reset</td> </tr> </table> <p style="text-align: right; font-size: small; margin-top: 5px;">12262E00</p> </div>	accept changes ?	yes -> CPM reset	<ul style="list-style-type: none"> <li>• Press the ▲ and ▼ buttons simultaneously. The following display appears (shown on the left).</li> </ul>				
accept changes ?							
yes -> CPM reset							
<div style="border: 1px solid black; padding: 5px; width: fit-content;"> <table style="width: 100%; border-collapse: collapse;"> <tr> <td style="padding: 2px;">accept changes ?</td> </tr> <tr> <td style="padding: 2px;">No</td> </tr> </table> <p style="text-align: right; font-size: small; margin-top: 5px;">12263E00</p> </div>	accept changes ?	No	<ul style="list-style-type: none"> <li>• Press the ▲ and ▼ buttons simultaneously. The settings are applied. The device reboots.</li> <li>or</li> <li>• Press the ▲ or ▼ button. The following display appears (shown on the left).</li> </ul>				
accept changes ?							
No							
	<ul style="list-style-type: none"> <li>• Press the ▲ and ▼ buttons simultaneously. The setting is cancelled.</li> </ul>						

	<p>After setting the fieldbus address, the device will reboot. The fieldbus address is permanently saved and remains available after a reset or recommissioning.</p>
---	--



## 10 Operation

### 10.1 Operation

After mounting, installation and commissioning (see the "Mounting and installation" and "Parameterisation and commissioning" chapters) the CPU & power module is ready for operation.

Please observe the additional documentation (coupling description).

### 10.2 Indicators

The corresponding LEDs on the device indicate the operating state of the device (see also the "Function and device design" chapter).

LED	Colour	Meaning
"RUN" LED	Green	Operation indication
"ERR" LED	Red	Module error indication

### 10.3 Troubleshooting

For troubleshooting, refer to the following troubleshooting guide:

Error	Cause of error	Troubleshooting
"RUN" LED (green) is lit, "ERR" LED (red) is off	CPM: OK I/O signal common alarm	see LED indicators of the I/O modules
"RUN" LED (green) is lit, "ERR" LED (red) is blinking	CPM: OK, I/O: Module common alarm <ul style="list-style-type: none"> <li>• Modules malfunctioning</li> <li>• Module not available</li> <li>• Incorrect module inserted</li> </ul>	<ul style="list-style-type: none"> <li>• Replace module</li> <li>• Insert module</li> <li>• Insert correct module</li> </ul>
"RUN" LED (green) is blinking, "ERR" LED (red) is off	In standby mode (switched on but no data exchange with master yet)	<ul style="list-style-type: none"> <li>• Activate the cyclical data exchange with the master.</li> <li>• Check master and bus connection to the CPM.</li> </ul>
"RUN" LED (green) is blinking, "ERR" LED (red) is blinking	Data Exchange mode has been exited (outputs are in safety position). Cyclical data exchange with master interrupted.	<ul style="list-style-type: none"> <li>• Activate the cyclical data exchange with the master.</li> <li>• Check master and bus connection to the CPM.</li> </ul>
"RUN" LED (green) is blinking, "ERR" LED (red) is lit	Configuration error. Configuration is not OK	Change configuration of master.
"RUN" LED (green) is off, "ERR" LED (red) is lit/is blinking Display: "Supply: fail"	CPM hardware error. <ul style="list-style-type: none"> <li>• Hardware check error</li> <li>• EPROM error</li> <li>• EEPROM error</li> </ul>	Replace CPM.
"RUN" LED (green) is off, "ERR" LED (red) is off	No supply voltage at the CPM or CPM defective.	<ul style="list-style-type: none"> <li>• Check the power supply of the CPM.</li> <li>• Check CPM.</li> <li>• Check BusRail.</li> <li>• Snap CPM correctly into place on BusRail.</li> <li>• Replace CPM.</li> </ul>

If the error cannot be eliminated using the specified procedures:

- Contact R. STAHL Schaltgeräte GmbH.

For rapid processing, have the following information ready:

- Type and serial number of the device
- DCS/PLC
- Protocol
- Revision no./firmware version
- Purchase information
- Error description
- Intended purpose (especially input/output circuit)

## 11 Maintenance, Overhaul, Repair

### 11.1 Maintenance

- Consult the relevant national regulations to determine the type and extent of inspections.
- Tailor inspection intervals to the operating conditions.

At a minimum, check the following points during maintenance on the device:

- Whether the clamping screws holding the electrical lines fit securely
- Whether the device has cracks or other visible signs of damage
- Whether the permissible ambient temperatures are observed
- Whether it functions as intended

### 11.2 Overhaul

The device does not require regular maintenance.

	Observe the relevant national regulations in the country of use.
---	--

### 11.3 Repair

	<b>DANGER</b>
	<p>Explosion hazard due to improper repair!                  Non-compliance results in severe or fatal injuries.</p> <ul style="list-style-type: none"> <li>• Repair work on the devices must be performed only by R. STAHL Schaltgeräte GmbH.</li> </ul>

## 11.4 Returning the Device

- Only return or package the devices after consulting R. STAHL!  
Contact the responsible representative from R. STAHL.

R. STAHL's customer service is available to handle returns if repair or service is required.

- Contact customer service personally.

or

- Go to the [r-stahl.com](http://r-stahl.com) website.
- Under "Support" > "RMA" > select "RMA-REQUEST".
- Fill out the form and send it.  
You will automatically receive an RMA form via email.  
Please print this file off.
- Send the device along with the RMA form in the packaging to  
R. STAHL Schaltgeräte GmbH (refer to chapter 1.1 for the address).

## 12 Cleaning

- Devices located in hazardous areas may only be cleaned with a damp cloth to avoid electrostatic charge.
- When cleaning with a damp cloth, use water or mild, non-abrasive, non-scratching cleaning agents.
- Do not use abrasive cleaning agents or solvents.

## 13 Disposal

- Observe national, local and statutory regulations regarding disposal.
- Separate materials for recycling.
- Ensure environmentally friendly disposal of all components according to statutory regulations.

## 14 Accessories and Spare Parts

### NOTICE

Malfunction or damage to the device due to the use of non-original components.

Non-compliance may lead to material damage.

- Use only original accessories and spare parts from  
R. STAHL Schaltgeräte GmbH.



For accessories and spare parts, see the data sheet on our homepage [r-stahl.com](http://r-stahl.com).

**EU-Konformitätserklärung**  
*EU Declaration of Conformity*  
*Déclaration de Conformité UE*



**R. STAHL Schaltgeräte GmbH • Am Bahnhof 30 • 74638 Waldenburg, Germany**  
 erklärt in alleiniger Verantwortung / declares in its sole responsibility / déclare sous sa seule responsabilité,

**dass das Produkt:** CPU & Power Modul  
*that the product:* CPU & Power Module  
*que le produit:* Module CPU & Alimentation

**Typ(en), type(s), type(s):** 9440/15-01-11

**mit den Anforderungen der folgenden Richtlinien und Normen übereinstimmt.**  
*is in conformity with the requirements of the following directives and standards.*  
*est conforme aux exigences des directives et des normes suivantes.*

Richtlinie(n) / Directive(s) / Directive(s)	Norm(en) / Standard(s) / Norme(s)
2014/34/EU ATEX-Richtlinie 2014/34/EU ATEX Directive 2014/34/UE Directive ATEX (OJ L 96, 29/03/2014, p. 309–356)	EN IEC 60079-0:2018 EN IEC 60079-7: 2015 / A1:2018 EN 60079-11:2012

**Kennzeichnung, marking, marquage:** II 3 (2) G Ex ec [Ia Ga] [Ib Gb] IIC T4 Gc **0158**

**EU-Baumusterprüfbescheinigung:** PTB 99 ATEX 2222 X  
*EU Type Examination Certificate:* Physikalisch-Technische Bundesanstalt,  
*Attestation d'examen UE de type:* Bundesallee 100, 38116 Braunschweig, Germany, NB0102

**Produktnormen nach Anhang II ATEX (aus Niederspannungsrichtlinie):** EN 61010-1:2010 / A1:2019 / AC:2019-04  
*Product standards according to Annex II ATEX (from Low Voltage Directive):*  
*Normes de produits selon l'annexe II ATEX (de la Directive Basse Tension):*

2014/30/EU EMV-Richtlinie 2014/30/EU EMC Directive 2014/30/UE Directive CEM (OJ L 96, 29/03/2014, p. 79–106)	EN 61326-1:2013
---	-----------------

2011/65/EU & (EU) 2015/863 RoHS-Richtlinien 2011/65/EU & (EU) 2015/863 RoHS Directives 2011/65/UE & (UE) 2015/863 Directives RoHS (OJ L 174, 1/07/2011, p. 88–110 & OJ L 137, 04/06/2015, p. 10-12)	EN IEC 63000:2018
--	-------------------

Unterzeichnet für und im Namen von: / signed for and on behalf of: / signé pour et au nom de:

**R. STAHL Schaltgeräte GmbH**

Waldenburg, 2023-10-25

**Ort und Datum**  
*Place and date*  
*Lieu et date*

**Jörg Stritzelberger**  
**Leiter Entwicklung Automation**  
*Director R&D Automation*  
*Directeur R&D Automation*

**Daniel Groth**  
**Leiter Qualitätsmanagement Systeme**  
*Director Quality Management Systems*  
*Directeur Systèmes de Management de la Qualité*



The copying, distribution and utilization of this document as well as the communication of its contents to others without expressed authorization is prohibited. Offenders will be held liable for the payment of damages. All rights reserved in the event of the grant of a patent, utility model or ornamental design registration.

Class I, DIV 2 / Zone 2 Installation for connection to I/O Modules located in Class I, II, III, Division 2, Group A-G, or Class I, Zone 2, Group IIC/IIB Hazardous (Classified) Locations

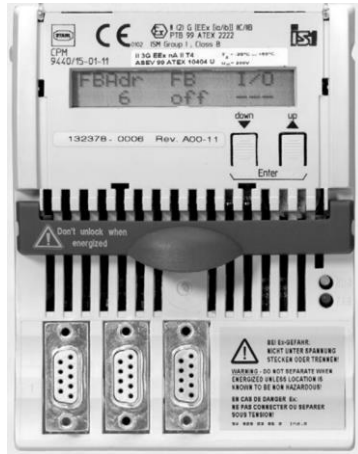

Connection allocation  
CPU & Power Module for Division 2 or Zone 2, type 9440/15-01-11

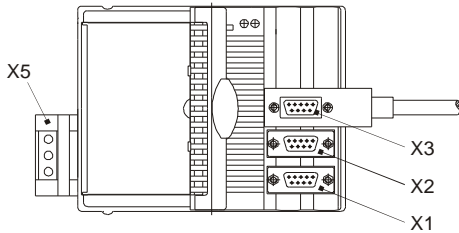
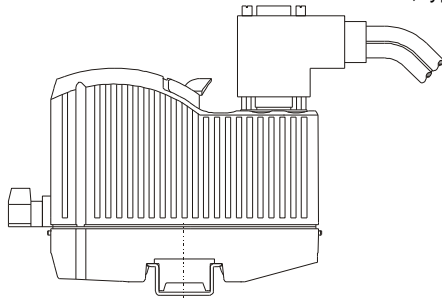

**Power supply (X5)**

Description	Function	Connector number	Terminal 3-pin name
	24 V DC (+)	X5	L+
	0 V	X5	L-
	Ground	X5	GND

**Fieldbus (X1, X2) and Service Bus (X3)**

Description	Function	Connector number	Sub-D 9 pin number
Data B (+)	RxD/TxD (+)	X1, X2, X3	3
Reference potential for the interface (out of the equipment)	GND	X1, X2, X3	5
Supply voltage (out of the equipment)	5 V (+)	X1, X2, X3	6
Data A (-)	RxD/TxD (-)	X1, X2, X3	8
-	Not connected	X1, X2, X3	1,2,4,7

**WARNING:** Do not disconnect equipment when a flammable or combustible atmosphere is present.  
**AVERTISSEMENT:** Ne pas débrancher l'équipement en présence d'atmosphère inflammable ou combustible.

The Type 9440/15-01-11 CPU & Power Module is a nonincendive module for installation in Class I, Division 2, Group A-D or Class I, Zone 2, Group IIC/IIB hazardous location; Providing intrinsically safe BusRail and nonincendive RS485 interfaces according to NEC Article 504/505 or Canadian Electrical Code, CSA C22.

Safety data for wiring configurations to the left are as follows:

**Power Supply (input/primary)** **Connector X5**  
 $U_{in} = 24 \text{ V DC (20 V ... 35 V DC)}$   
 $I_{in} = 5.2 \text{ A}$   
 $U_{max} = 250 \text{ V}$

**Data interfaces RS 485 (primary)** **Connectors X1, X2, X3**  
 Data circuits as per I/O Standard **RS 485**  
 $V_{max} = 250 \text{ V}$

Nonincendive connections  
 $V_{OC} = 13.2 \text{ V, } I_{SC} = 110 \text{ mA}$   
 $C_i = 0.12 \mu\text{F, } L_i = 0 \text{ mH}$   
 $U_{max} = 13.2 \text{ V, } I_{max} = 110 \text{ mA}$   
 $C_a = 5 \mu\text{F, } L_a = 6.5 \text{ mH}$

**Module 1-16 over BusRail:**

CL I, DIV 1, A-D / CL I Zone 1, GP IIC/IIB:

Power Supply (output/secondary):

With intrinsically safe type of protection:

Maximum value:  $V_{OC} = 26.2 \text{ V}$

The circuit requires external current limitation which is provided by the system

Address and data bus (secondary):

With intrinsically safe type of protection:

Maximum values:  $V_{OC} = 6.6 \text{ V}$

$I_{SC} = 105 \text{ mA}$

$V_{max} = 6.6 \text{ V}$

Linear characteristic curve, the effective internal capacitance and inductance are negligibly small.

**Notes:**

- For Entity concept use the appropriate parameters from above to ensure the following:  
 $V_{OC} \text{ or } V_t \leq V_{max}$      $C_a \geq C_i + C_{leads}$   
 $I_{SC} \text{ or } I_t \leq I_{max}$      $L_a \geq L_i + L_{leads}$
- Electrical Apparatus connected to an intrinsically safe system must not use or generate voltages > 250 V ( $U_{max}$ )
- Do not connect or disconnect non I.S. power supply to X5 unless area is known to be non-hazardous.
- Do not detach from or plug the CPU & Power Module to the BusRail when energized, unless area is known to be non-hazardous.
- General Notes see Certification drawing for IS1 resp. IS1+ Remote I/O System No. 9400 6 031 004 1

Weitergabe sowie Vervielfältigung dieses Dokuments, Verwertung und Mitteilung seines Inhalts sind verboten, soweit nicht ausdrücklich gestattet. Zuwiderhandlungen verpflichten zu Schadensersatz. Alle Rechte für den Fall der Patent-, Gebrauchsmuster- oder Geschmacksmusterrechte vorbehalten.

F 4830 503

			2016	Date	Name	<b>Certification drawing</b> <b>CPU &amp; Power Module</b> <b>Type 9440/15-01-11</b>	Scale	none
			Drawn by	03.03.	Bagusch		Sheet	1 of 1
			Checked		Kaiser		Agency	FM
Version	Date	Name				9440 6 031 002 1		
			Rep. f.			Rep. t.		A4

The copying, distribution and utilization of this document as well as the communication of its contents to others without expressed authorization is prohibited. Offenders will be held liable for the payment of damages. All rights reserved in the event of the grant of a patent, utility model or ornamental design registration.

**Example for System Topology interfacing Automation control systems with DIV 2 / Zone 2 installation of IS1 resp. IS1+ Remote I/O System:**

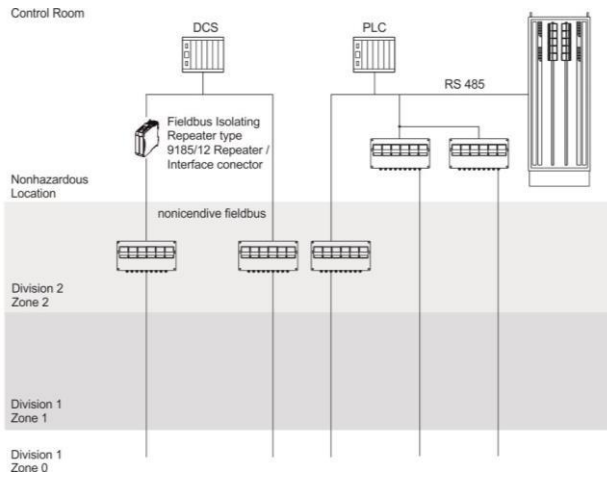

**Example for Ethernet System Topology with Isolators interfacing Automation control systems with DIV 2 / Zone 2 installation of IS1 resp. IS1+ Remote I/O System:**

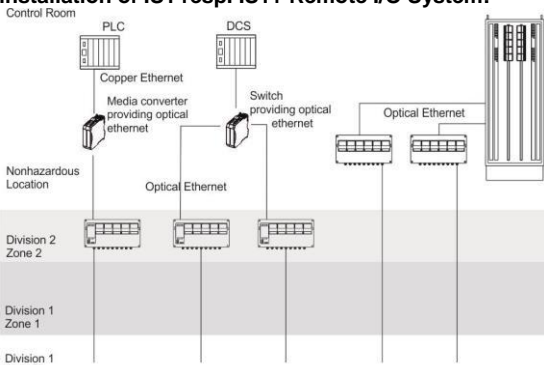

**Service Bus with Isolating Repeater interface:**

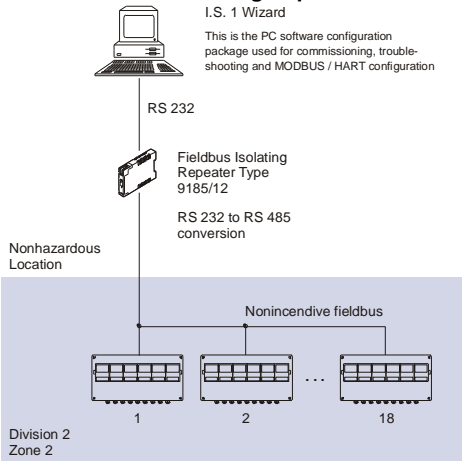

**Mounting direction:**

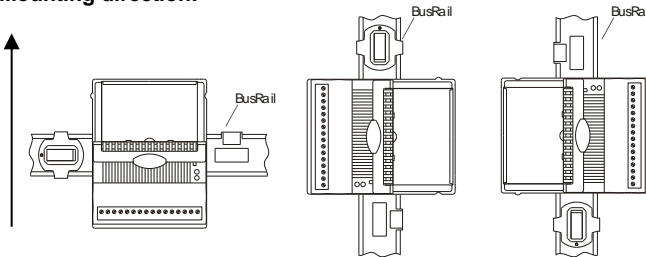

The IS1 resp. IS1+ Remote I/O is a DIN rail mounted system designed to record and output process control signals between hazardous location transducers and sensors and a nonhazardous location automation system. It consists of electrical apparatus in the nonhazardous, Class I, Division 2 or Class I, Zone 2 hazardous locations linked by either nonincendive field bus or a field bus installed per the National Electrical Code, ANSI/NFPA 70 Article 500 or Canadian Electrical Code, CSA C22.

Installation with the use of an appropriate fieldbus isolator for nonincendive fieldbus circuits (e.g. R. STAHL type 9185). The Ethernet interface is achieved with the use of media converters and switches providing optical Ethernet.

These devices reside in the unclassified (nonhazardous) location or Division 2 / Zone 2 locations and provide a connection to the IS1 resp. IS1+ Remote I/O System. See examples to the left.

The apparatus located in the Division 2 or Zone 2 hazardous location are referred to as Remote I/O, and consist of the following major subsystems.

- CPU & Power Module or CPU Module, Power Module & Socket**  
The CPU & Power Module or the Power Module serves as a power supply unit for its CPU unit or the CPU Module, as well as for the supply to the I/O Modules and the field circuits. The power supply to the I/O Modules is implemented via the BusRail. For the configuration with a redundant CPU and Power Module the power supply to the I/O Modules is decoupled with diodes. The power supply unit has an under voltage monitoring circuit. The CPU fulfils the function of a gateway between the internal bus of an IS1 field station and the fieldbus which connects the field station with the automation system. The gateway is constructed as a dual processor system. The I/O processor controls the data exchange with the I/O Modules and, when plugged-in, with the redundant CPU & Power Module. The communication processor controls the data exchange on the fieldbus and on the Service Bus.
- BusRail**  
The BusRail provides a Power bus, an internal data bus and the address lines for the interconnection of the CPU & Power Supply to Remote I/O Modules. The Power bus distributes power supplied by the CPU & Power Module to the I/O Modules plugged to the BusRail. The communication with the I/O Modules is implemented via the address and data bus lines. The interface of the CPU & Power Module with the internal data bus on the BusRail is designed with redundancy.
- Components of Remote I/O System**  
All I/O Modules are manufactured in a unique DIN rail mount package which then mounts onto the Remote I/O system BusRail. All I/O Modules provide galvanic isolation between the field circuits and the BusRail's circuits.

**GENERAL NOTES:**

- Installation should be in accordance with Article 504/505 of the National Electrical Code, ANSI/NFPA 70 and ANSI/ISA RP12.06.01.
- Installation in Canada should be in accordance with the Canadian Electrical Code, CSA C22.1, Part 1
- Use a general purpose enclosure meeting the requirements of ANSI/ISA 61010-1 for use in nonhazardous or Class I, Division 2 or Class I, Zone 2 hazardous (classified) locations.
- Use an FM Approved or NRTL listed Dust tight enclosure appropriate for environment protection in Class II and III, Division 2, Groups E, F and G, hazardous (classified) locations.
- All I/O Modules may be detached from the BusRail or plugged onto it during operation in hazardous areas.
- Mount the device in a vertical direction, with the reading of the marking from below, left or right, or in a horizontal direction with the terminals nearest the bottom of the enclosure. Never mount the IO modules upside down (terminals towards the top of the enclosure). As shown to the left.

WARNING: Substitution of components may impair Intrinsic Safety.  
AVERTISSEMENT: Substitution de composants peut compromettre la sécurité intrinsèque.

Weitergabe sowie Vervielfältigung dieses Dokuments, Verwertung und Mitteilung seines Inhalts sind verboten, soweit nicht ausdrücklich gestattet. Zuwiderhandlungen verpflichten zu Schadensersatz. Alle Rechte für den Fall der Patent-, Gebrauchsmuster- oder Geschmacksmusterrechte vorbehalten.

F 4830 503

2016	Date	Name	Certification drawing <b>IS1 resp. IS1+ Remote I/O System for CL I, DIV 2 / Zone 2 Overview</b>	Scale	
Drawn by	03.03.	Bagusch		none	
Checked		Kaiser		Sheet 1 of 2	
			Agency	FM	
			9400 6 031 004 1		
Version	Date	Name	Rep. f.	Rep. t.	A4

**Block Diagram of an RS485 Field Station:**

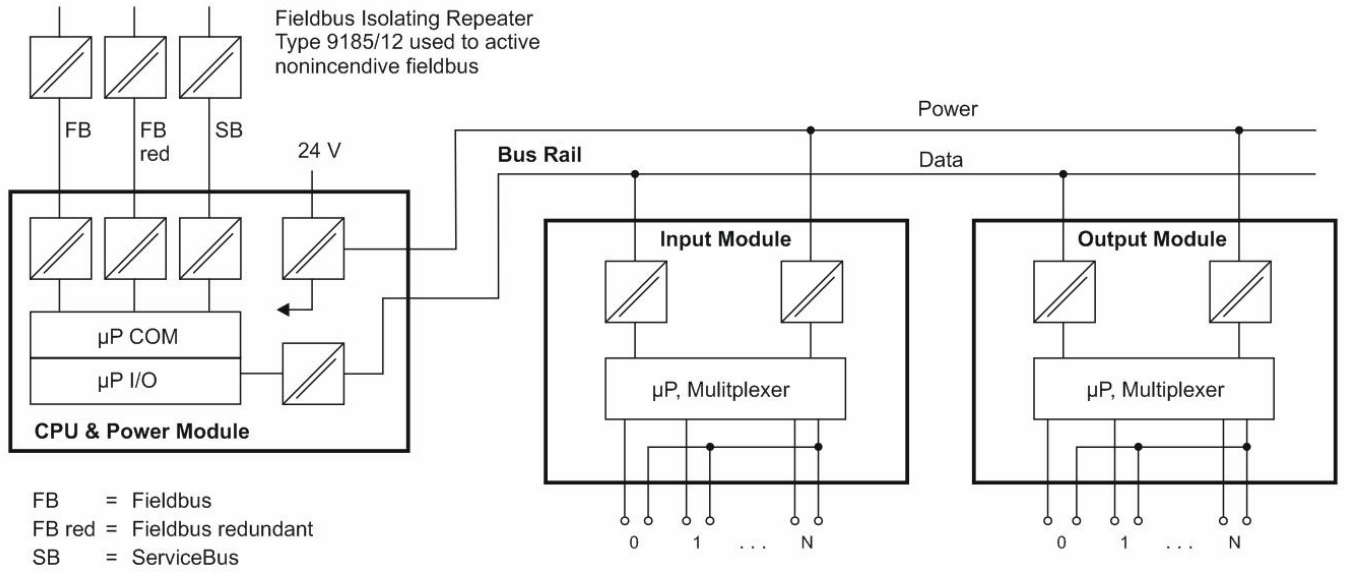

FB = Fieldbus  
 FB red = Fieldbus redundant  
 SB = ServiceBus

I.S. Inputs and Outputs  
 Class I, II, III, DIV 1, Groups A-G; Class I, Zone 0, IIC/IIB  
 or Non I.S. or Nonincendive circuits,  
 Class I, II, III, DIV 2, Group A-G; Class I, Zone 2, Group IIC/IIB

**Block Diagram of an Ethernet Field Station:**

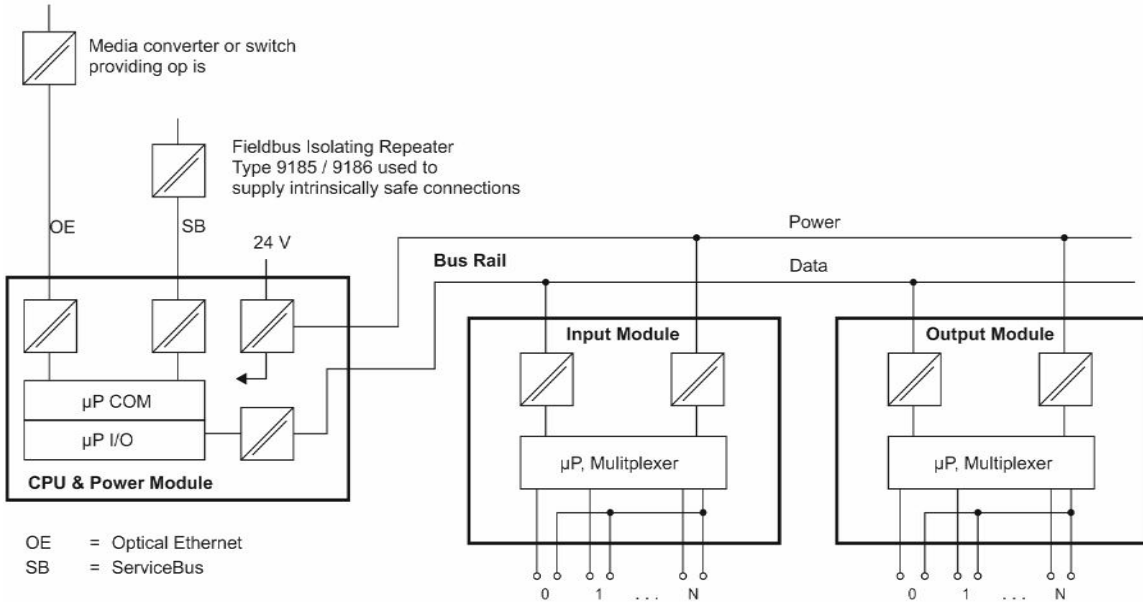

OE = Optical Ethernet  
 SB = ServiceBus

I.S. Inputs and Outputs  
 Class I, II, III, DIV 1, Groups A-G; Class I, Zone 0, IIC/IIB  
 or Non I.S. or Nonincendive circuits,  
 Class I, II, III, DIV 2, Group A-G; Class I, Zone 2, Group IIC/IIB

**Construction example for assembly of an IS1 resp. IS1+ System:**  
 DIV 2 / Zone 2 assembly illustration shown



			2016	Date	Name	Certification drawing <b>IS1 resp. IS1+ Remote I/O System</b> for CL I, DIV 2 / Zone 2 <b>Overview</b>		Scale
			Drawn by	03.03.	Bagusch			Sheet
			Checked		Kaiser			2 of 2
			<b>STAHL</b>			9400 6 031 004 1		Agency
								FM
Version	Date	Name				Rep. f.	Rep. t.	A4