

Description of

MODBUS Interface

RTU / TCP

for

IS1+ field stations



MODBUS interface description

Content:

Historical development of remote I/O technology at R. STAHL.....	4
1 System overview	5
1.1 MODBUS TCP	5
1.2 MODBUS RTU	7
2 Commissioning.....	8
2.1 Overview	8
2.2 System requirements	10
2.3 Engineering limits.....	10
2.4 Compatibility of new IS1+ IOM.....	11
2.5 MODBUS TCP Network Topology	12
2.6 RS485 MODBUS RTU Bus segments	12
2.7 Addressing of 9440 CPM	13
2.8 Addressing of 9441 CPUs.....	13
2.8.1 BOOTP (Bootstrap Protocol)	13
2.8.2 Address Conflict Detection (ACD).....	14
2.9 Addressing and Protocol selection 9442 CPUs	14
2.9.1 DP/RS485 + SB Address setting	14
2.9.2 Protocol Selection	15
2.9.3 IP Address setting.....	15
2.9.3.1 IS1+ Detect.....	16
2.9.3.2 IS1+ Web Server.....	17
2.10 System start-up behavior	18
2.11 MODBUS Functions.....	19
2.11.1 MODBUS-FUNCTION 08 - Diagnostics	20
2.11.2 MODBUS-FUNCTION 43 (0x2B) - Read Device Identification	20
2.11.3 MODBUS error codes	21
2.11.4 MODBUS TCP Multi Client operation	22
3 Data traffic	23
3.1 Signal marshalling.....	23
3.1.1 Input and Output Signal blocking.....	24
3.1.1.1 Register allocation of I/O data.....	26
3.1.2 Signal Type blocking (DI, AI, HV, DO, AO).....	28
3.1.3 Configuration example IS1 Fieldstation	31
3.1.4 Rules for message processing:.....	32
3.1.5 Extract from the allocation table	33
3.2 Status register CPU.....	34
3.3 Control register	35
3.4 Module alarms.....	36
3.5 Signal status.....	37
3.6 CPU Redundancy.....	38
3.6.1 Non redundant Ethernet Network	38
3.6.2 Redundant Ethernet Networks.....	39
3.6.3 Ethernet IP- Addresses:.....	40
3.6.4 Parameterization:	40
3.6.5 Selection of 'CPU start condition'	40
3.6.6 Download of Configuration and Parameter data to redundant CPUs.....	41
3.6.7 HART	41
3.6.8 Diagnosis using IS1 DTMs.....	41
3.6.9 WEB Server der IS1+ CPUs	42
3.6.10 Process data of CPUs during redundancy switch over	42
3.6.11 State of redundant 9441 CPUs.....	43
3.6.12 Prepared / deactivated redundancy of 9441 CPUs	45

MODBUS interface description

3.7	Setting parameters for the IS1+ field station.....	45
3.7.1	CPU parameters	46
3.7.2	I/O module parameters	47
3.7.2.1	AIM / AIMH 9461	47
3.7.2.2	AUMH 9468.....	48
3.7.2.3	UMH 9469 Exn.....	50
3.7.2.4	TIMR 9480.....	52
3.7.2.5	TIM mV 9481.....	53
3.7.2.6	TIM 9482	54
3.7.2.7	DIM (9470/3x in compatible mode).....	55
3.7.2.8	DIOM 9470/3x (IS1+)	56
3.7.2.9	AOM / AOMH 9466	57
3.7.2.10	DOM	58
3.8	Data word structure of the I/O modules	59
3.8.1	Analogue modules	59
3.8.1.1	AIM, AIMH (9460/..., 9461/..., 9468/..., 9469/..).....	59
3.8.1.2	TIM (9480/.. , 9481/.. , 9482/..).....	62
3.8.1.3	AOM 0 – 20 mA (9465/... , 9466/..., 9468/.., 9469/..).....	65
3.8.2	DIM, DIM+CF (9470/.. 9471/.. 9472/..)	67
3.8.3	DOM (9475/.., 9477/.., 9478/..)	73
3.9	Signal behavior in case of errors.....	74
3.9.1	Behavior of the input signals in case of errors	74
3.9.2	Behavior of the output signals in case of errors.....	75
3.10	HART variables	76
3.10.1	Module selection in IS1 DTM	77
3.10.2	Data format	77
3.10.3	Routed HART Variables.....	78
3.10.4	Modbus Mapping of the extended HART data.....	79
3.10.5	HART Livelist	82
3.11	IS1 DTMs	83
3.12	Webserver.....	84
3.12.1	Webserver 9141 CPU	84
3.12.2	Webserver 9442 CPU	85
3.13	LED and LCD-displays of the CPUs	86
3.14	Online behavior of the IS1+ field station.	86
3.14.1	Parameter changes.....	86
3.14.2	Configuration changes.	86
3.15	Transmission time	87
3.15.1	MODBUS RTU.....	87
3.15.2	MODBUS TCP.....	88
4	List of abbreviations.....	89
5	Release notes:.....	90
6	Further reading	90
7	Support address	90

MODBUS interface description

Historical development of remote I/O technology at R. STAHL

As one of the innovators in remote I/O technology, R. STAHL recognized the advantages that remote I/O technology offers for hazardous areas and has been developing innovative products and solutions for over 30 years since that time. The benefits to users are always the focus here. All communication, power supply and input/output modules in the system can be connected and disconnected during operation in hazardous areas. Thanks to an intrinsically safe system design, the installation process is almost identical to this process in safe areas. No special Ex d or Ex p enclosures are required. Remote I/O can be used to integrate conventional and HART-capable field devices into modern, digital network structures easily and affordably. Comprehensive diagnostics options using a separate ServiceBus or the process bus enable integration in modern plant asset management systems and increase the availability of systems.

- 1987 The "ICS MUX fieldbus system" from R. STAHL is the first intrinsically safe bus system for sensors and actuators in hazardous areas (Zone 1) on the market. A master station installed in the control room establishes the connection to the automation systems. Intrinsically safe communication with explosion-protected on-site or field stations (VOS) installed in Zone 1 is carried out using a single coaxial cable.
- 1993 The system variant "VOS 200", which is based on ICS MUX, is presented. The "VOS 200" is better suited to smaller signal quantities or decentralized automation units. A master station is no longer required. Multi-drop is supported and couplings are also available in redundant designs.
- 1997 "VOS 200" can now also communicate with the PROFIBUS DP, which was new at the time. R. STAHL achieved this by being the first to develop an intrinsically safe design which, with a few modifications, is part of the PNO standard today under the name RS485-IS.
- 2000 Drawing from experience with the ICS MUX and VOS 200, a completely new Remote I/O – IS1 is developed. This system is substantially more flexible, easier to use, more powerful and extremely affordable. Over the years, the IS1 has become the market leader in Zone 1 and is still used around the globe. IS1 supports open bus protocols such as PROFIBUS DP or Modbus RTU and is available in different versions for Zone 1, Zone 2 and even Division 1 and 2.
- 2009 A new communication unit for Ethernet is added to IS1. With this, IS1 is the first remote I/O system that operates at 100 Mbps/Ethernet in Zone 1. A fibre optic cable with the 'op is' type of protection is used as a communication medium. Modbus TCP, EtherNet/IP and PROFINET are supported protocols.
- 2013 The I/O level is completely modernised and introduced on the market as IS1+. The new multifunctional I/O modules have configurable inputs/outputs and an innovative diagnostics function that reports potential module failures up to 12 months before they would occur. IS1+ is even better suited to extreme ambient conditions from -40 to +75 °C. The new IS1+ modules are fully compatible with their IS1 predecessors.
- 2018 The new Zone 2 head assembly consists of a CPU, power module and socket makes IS1+ even more flexible and has expanded its application range. The previously supported protocols PROFIBUS DP, Modbus TCP+RTU, EtherNet/IP and PROFINET are now all supported by one CPU and can be selected by the user. The new assembly has the same predictive diagnostic functions and the extended temperature range of -40 to 75 °C that are features of the IS1+ modules.

The description below shows the system features of the IS1+ system when connecting to an automation system via MODBUS TCP or MODBUS RTU

MODBUS interface description

1 System overview

1.1 MODBUS TCP

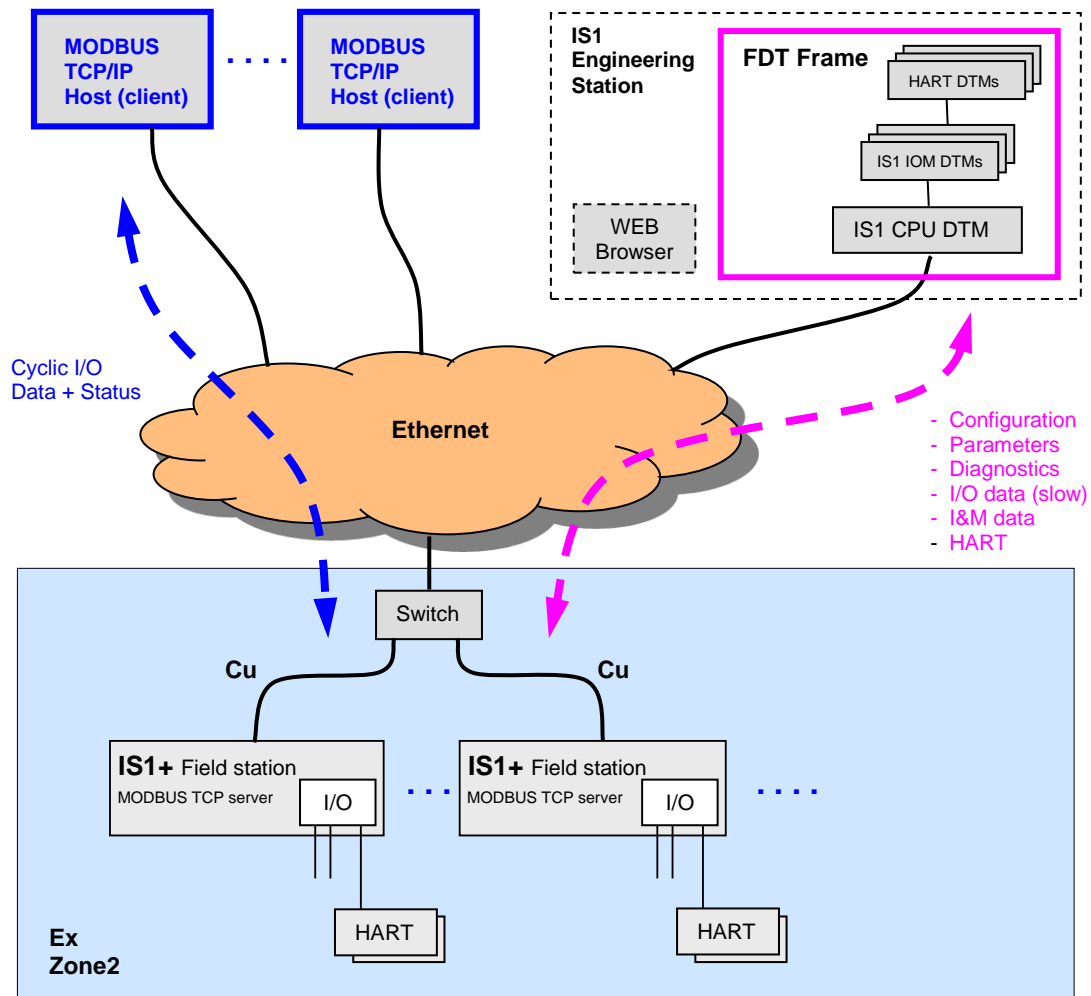

As an off-the-shelf explosion protected unit, the IS1+ field station can be installed directly in the potentially explosive atmosphere (Zone 1 or Zone 2). It can also be installed in the safe area. The diagram above shows a Zone 2 solution.

The IS1+ field station comes with an Ethernet connection and operates as a MODBUS TCP server. Optionally a RS 485-IS service bus can be used.

Configuration, parameter setting, diagnostics and HART communication for the IS1+ field station and its I/O modules are carried out via IS1 DTMs interfaced using FDT technology.

A webserver is integrated in the IS1 CPUs which offers additional diagnostic functions.

[List of abbreviations](#)

MODBUS interface description

Separate networks with Routing via DCS/PLC:

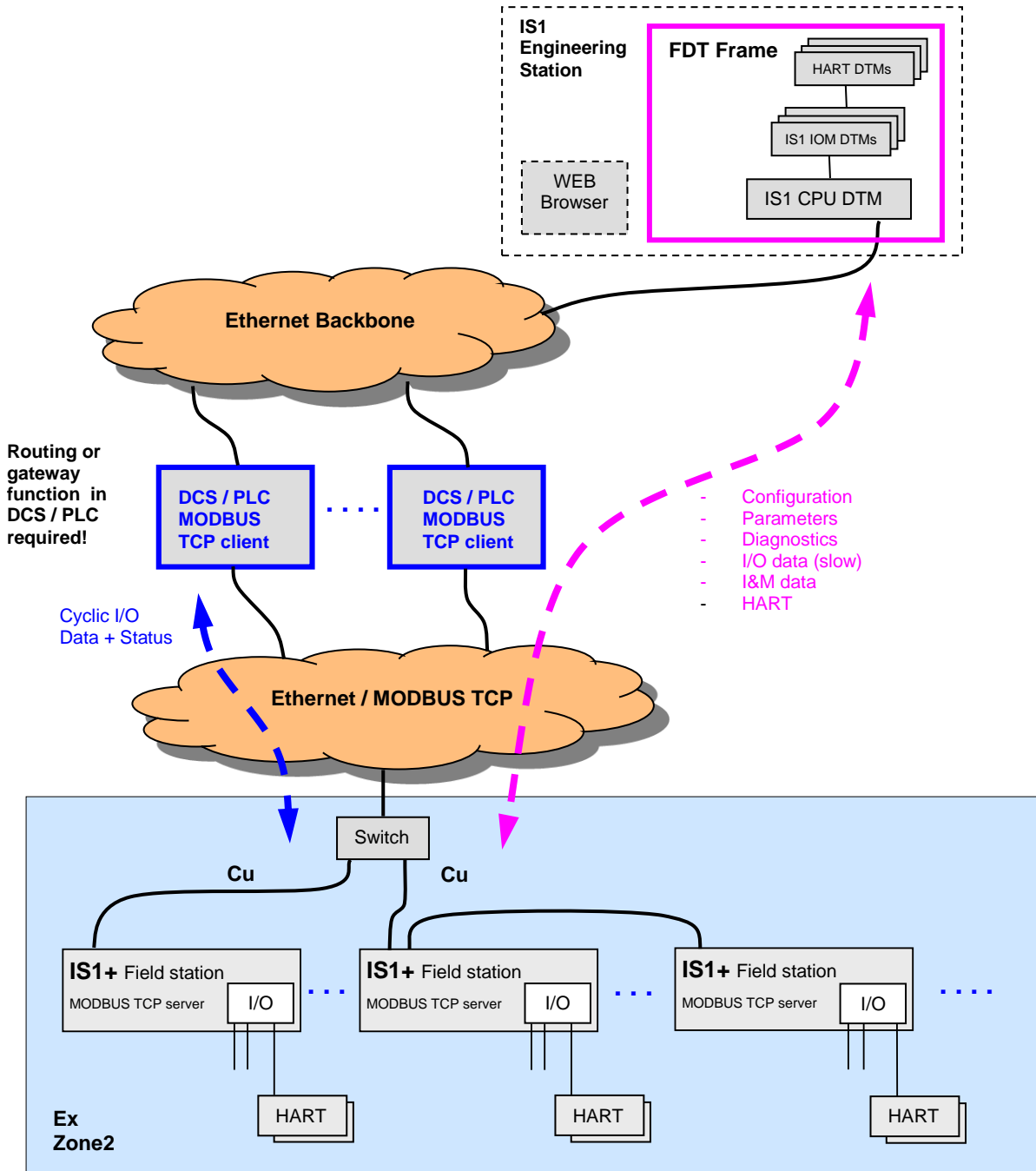

MODBUS interface description

1.2 MODBUS RTU

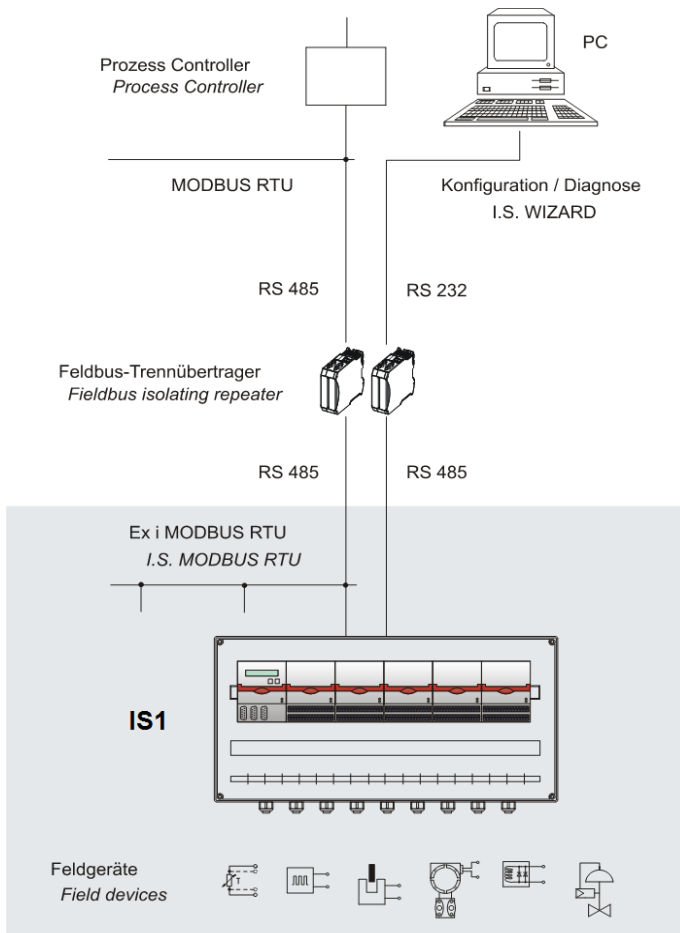

As an off-the-shelf explosion protected mounted unit, the IS1+ field station can be installed directly in the hazardous area (Zone 1 or Zone 2). It can also be installed in the safe area. The adjacent diagram shows a Zone 2 solution with 9440 CPM.

The IS1+ field station has two serial interfaces. One of them is used to connect to an automation system and the second serial interface can be used as a bus-capable maintenance interface for the configuration, error diagnosis and communication with HART field devices.

Several IS1+ field stations can be used in the hazardous area to form a MODBUS network that is connected directly - both hierarchically and topologically - with the MODBUS network in the non-hazardous area.

The following applies to Zone 1 installations: From a safety-engineering aspect relating to explosion protection, the field bus isolating repeater for the MODBUS takes on the function of a "barrier" between the ex area and non-hazardous area. The field bus isolating repeater operates as a repeater.

In such a MODBUS network, the IS1+ field station behaves hierarchically as a MODBUS slave where the configuration of the field station with its I/O modules is performed via the service Bus with the software IS Wizard.

MODBUS interface description

2 Commissioning

2.1 Overview

Planning of the complete MODBUS network:

- Which masters (clients) are in the network
- Which slaves (servers) are in the network
- Selection of network topology and network physics (switches, repeaters, glass fiber links ...)
- Unique allocation of the Slave- or IP addresses.

Perform the commissioning:

- Mechanical installation of the IS1+ field station.
- Mechanical installation of the Ethernet switches or Fieldbus Isolating Repeaters
- Mechanical installation of all other bus users.

- Set up the bus connections.

MODBUS TCP:

- Set up the voltage supply of the IS1+ field station.
- Set up the voltage supply of the switches and other network components

- Install IS1+ detect tool on PC for support of 9442 CPUs.
- Set up the IP addresses, Subnet Mask, Gateway
 - 9441 CPU: on the IS1 Fieldstations using buttons and display
 - 9442 CPU: using IS1+ Detect Tool and IS1+ Web-Server

- Set up the addresses of all other users.

- Install a FDT Frame and the IS1 DTMs on the PC.
- Configure the IS1+ field stations with its I/O modules using the FDT software.

- Set parameters for the MODBUS TCP clients (masters):
Configuration of MODBUS messages in MODBUS TCP clients according the I/O modules in the IS1 field stations.

- Put the MODBUS master into operation. This results in the automatic start-up of the cyclic client <-> server communication.

- Check Ethernet connection using:
 - LED's on Ethernet Switches
 - Link LED's of CPU on IS1+ Fieldstation
 - „Ping“ command. Ping is responding in any IS1+ CPU state.

- Check communication on the MODBUS TCP using the following tools:
 - Diagnostics information from the client (master) or from the diagnostic tools for the master.
 - LEDs on the CPU of the IS1+ field station and text display using 9441 CPUs
 - Webserver in IS1+ CPU

- Check I/O signals using the following tools:
 - Information from the client (master) or from the diagnostic tool for the master.
 - Use of diagnostics functions for the IS1 DTMs.

MODBUS interface description

MODBUS RTU:

- Set up the baud rate on the field bus isolating repeaters (9185, 9186,).
- Set up the voltage supply of the IS1+ field station.
- Set up the voltage supply of the isolating repeaters.
- Set up the slave addresses on the IS1+ field stations.
- Set up the addresses of all other users.
- Optional use of the service bus:
 - Mechanical mounting of the service bus and the associated field bus isolating repeater.
 - Install the IS Wizard software on the PC.
 - Select extended parameter set of IS1.
 - Configure the IS1+ field stations with its I/O-modules with the software IS Wizard.
- Parameterise the Modbus master:
Configuration of Modbus telegrams in MODBUS master according the I/O-modules in the fieldstations.
- Put the master into operation. This results in the automatic start-up of the cyclic master <-> slave communication.
- Check communication on the MODBUS using the following tools:
 - Diagnosis information of the master or of the diagnostic tools belonging to the master.
 - LEDs on the 9185, 9186 field bus isolating repeaters
 - LEDs on the CPM of the IS1+ field station
- Check I/O signals using the following tools:
 - Information of the master or of the diagnostic tool belonging to the master.
 - Use of Diagnosis software IS WIZARD on a PC connected via the service bus.

MODBUS interface description

2.2 System requirements

Hardware requirements:

- CPM 9440/12-01-11 (24V Z1 Stahl) from Revision F
- CPM 9440/15-01-11 (24V Z2 Stahl) from Revision F
- CPM 9440/22-01-11 (24V Z1 PNO) all Revisions
- CPM 9440/22-01-21 (230V Z1 PNO) all Revisions

- IS1 field station with CPU 9441/1x-00-00
Single socket 9492/12-11-11 or redundant socket 9492/12-11-12

- IS1+ field station with CPU 9442/35-10-00, socket 9496/.. and Power Module PM 9445/..

Software requirements:

IOM	IOM Firmware	9440 CPM Firmware	9441 CPU Firmware	9442 CPU Firmware	IS1 DTM (TCP)	IS Wizard (RTU)
IS1 IOM	from 02-00	from V11-06	from V21-08	from V1.0.8	from V3.0.13	from V3.2.11
IS1+ IOM (94xx/3x....)	from 03-01	from V11-11	from V21-16	from V1.0.8	from V3.0.13	from V3.2.11

2.3 Engineering limits

The general regulations according to the IS1 operating instructions apply to the engineering of an IS1+ field station.

Possible limitations due to MODBUS TCP clients:

- number of I/O modules or the maximum number of signals
- maximum number of slaves in a network

Thus, the limits on the MODBUS TCP clients used must also be taken into account during the engineering.

MODBUS interface description

2.4 Compatibility of new IS1+ IOM

New IS1+ IOM can be used in existing plants for compatible replacement of previous IS1 IOM.

No change of GSD File or configuration is required in such case.

The IS1+ IOM switch to a compatible mode in case of detection of an allowed configuration of the previous IOM.

If new features of the IS1+ IOM shall be used which are not supported by the previous IOM new configuration with the IS1 DTMs according type number of the IS1+ IOM is required.

Overview of compatible IOM:

IS1 IOM		compatible IS1+ IOM	Remark
9460/12-08-11	AIM 8	9468/32-08-11 AUMH Zone 1 9468/33-08-10 AUMH Zone 2	-
9461/12-08-11	AIMH 8		-
9461/12-08-21			9164 additionally required
9465/12-08-11	AOM 8		-
9466/12-08-11	AOMH 8		-
9461/15-08-12	AIMH 8 Exn	9469/35-08-xx UMH Exn	-
9466/15-08-12	AOMH 8 Exn		-
9470/12-16-11	DIM 16	9470/32-16-11 DIOM Zone 1	-
9470/22-16-11		9470/33-16-10 DIOM Zone 2	-
9475/12-08-41	DOM 8		for low power valves
9470/25-16-12	DIM 16 Nam Exn	9471/35-16-xx DIOM Zone 2 Exn 9472/35-16-xx DIOM 24V Exn (from IOM Firmware V03-06)	-
9471/15-16-12	DIM 16 24V Exn		-
9471/10-16-11	DIM 16 24V		-
9475/12-04-11	DOM 4	9475/32-04-12 DOM Zone 1	-
9475/12-04-21		9475/32-04-22 DOM Zone 1	-
9475/12-04-31		-	discontinued
9475/12-08-41	DOM 8	siehe oben 9470/3x DIOM	-
9475/12-08-51		9475/32-08-52 DOM Zone 1 9475/33-08-50 DOM Zone 2	-
9475/12-08-61		9475/32-08-62 DOM Zone 1 9475/33-08-60 DOM Zone 2	-
9475/22-04-21		DOM 4 OD	9475/32-04-22 DOM Zone 1
9475/22-08-51	DOM 8 OD	9475/32-08-52 DOM Zone 1	-
9475/22-08-61		9475/32-08-62 DOM Zone 1	-
9480/12-08-11	TIM R	9482/3x-08-xx 8TIM	-
9481/12-08-11	TIM mV		-

MODBUS interface description

2.5 MODBUS TCP Network Topology

The IS1 + 9442 CPU has two Ethernet ports (X2, P1, as well as X2, P2) which are internally connected via an Ethernet switch. Thus, it is possible to build Ethernet line topologies (daisy chains).

Attention! A ring management is unspecified for MODBUS TCP. Therefore no Ringtopologies may be built up. This would lead to a broadcast storm and a failure of the Ethernet network. Ethernet Ringtopologies are supported from 9442 CPU by the use of PROFINET or EtherNet IP.

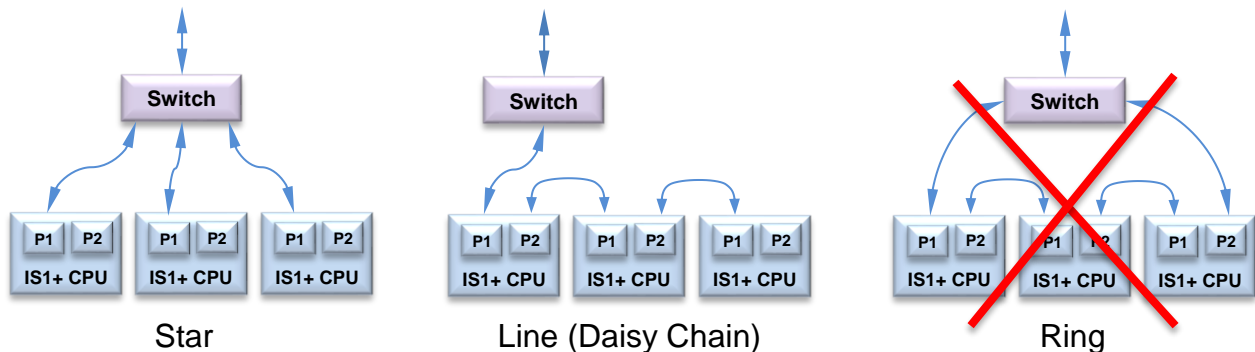

Maintenance Note: The internal switch and the Port P2 of a 9442 CPU are disabled during a software update. Following Network participants connected on port P2 are therefore unavailable in this phase of the operation.

2.6 RS485 MODBUS RTU Bus segments

A MODBUS network is based on RS485 bus physics with a twisted pair cable as the transmission medium. A network can consist of several **line-type** segments that are connected by repeaters or optical transmission routes.

The 9185 field bus isolating repeater can be seen as a repeater that connects a non-hazardous bus segment with an I.S. bus segment (RS485IS).

Bus termination

Every RS485 bus segment must be terminated at the first and last device of a segment with a bus termination resistor.

End of line resistor in Ex i segment see **operating instructions**:

Project Planning, Installation and Commissioning of the RS 485 Fieldbus System from R. STAHL for Non- Hazardous and Hazardous Areas.

Baud rate

The setting of Baudrate, Parity for the RS485 MODBUS RTU interface on terminal X1 of the CPU can be done via the IS Wizard software over the service bus.

Attention!

The selected baud rate for the 9185 or 9186 field bus isolating repeaters must be set on DIP switches.

MODBUS interface description

MODBUS RTU Interface parameters X1, RS485

Parameter	Selection	Selection by:
Baudrate	9600, 19200, 38400 Baud	IS Wizard (see CPM Parameter)
Parity	Odd, Even	
Startbit	1	fix
Stopbit	1	fix
Silent interval between request and response	> 3,5 characters	fix

2.7 Addressing of 9440 CPM

The setting of the RS 485 address (Modbus slave address) of an IS1 field station is performed by means of operating keys on the CPM module.

An address within the range 0 to 127 can be given here. Please note that addresses may only be allocated once in a MODBUS network.

The address that is set on the CPM is also valid for addressing the IS1 field station on the service bus. (see also the 9440 CPM operating manual)

2.8 Addressing of 9441 CPUs

The following information is required to address an IS1 field station:

- IP address
- SubNet mask
- optional: Port for the MODBUS server
- optional: Gateway (only necessary for communication via routers)

The addresses for an IS1 field station with 9441 CPU can be set via:

- Buttons and display on IS1 CPU.
- IS1 webserver
- The optional MODBUS server port can be set via the IS1 DTMs as a MODBUS parameter.

Attention! The IP addresses must be unique in the network.

Hint: The 'Unit Identifier' address also transferred via MODBUS TCP for serial MODBUS devices from the MBAP header is not used from the IS1 CPU!

2.8.1 BOOTP (Bootstrap Protocol)

IS1 supports the setting of IP Address via BOOTP Protocol according RFC951.

The IS1 Fieldstation must be configured in a BOOTP server which must be present on the Ethernet network. The IP-Address for the IS1 CPU must be allocated to its MAC-Address.

After power on the IS1 CPU checks the availability of a BOOTP server on the network and receives its IP address from this BOOTP server. The IP address is stored non volatile in the socket of the IS1 CPU.

If no BOOTP server is detected or the IS1 CPU is not configured in the BOOTP server then the IS1 CPU use the previous non volatile stored IP address.

MODBUS interface description

2.8.2 Address Conflict Detection (ACD)

Double IP addresses in one Ethernet Network can lead to unforeseeable behavior. To detect and to handle such situations ACD according RFC5227 was defined. IS1 is supporting this feature. Additionally the specification 'IPv4 Address Conflict Detection for EtherNet/IP Devices' was considered.

Address conflict during startup:

After power on start up the IS1 CPU checks for other devices with the same IP address on the network. In case of conflict the IS1 CPU stops further standard communication on Ethernet and checks in the background if the conflict is still present.

Address conflict during operation:

Depending on the behavior of the conflict partner the IS1 CPU or the conflict partner can withdraw from communication on Ethernet network.

Behavior of IS1 CPU in case of own withdraw from communication

- Error LED(red) at IS1 CPU = On
- LCD Display: IP conflict stop
- Error Message in event memory of IS1 CPU
- PLC, IS1 Webserver and IS1 DTM: no connection to IS1 CPU

About 1 minute after removal of the IP address conflict through changes on the conflict partner the IS1 CPU will restart its own communication.

Behavior of IS1 CPU in case of withdraw from communication of the communication partner

- No error on Error LED and LCD Display
- IS1 CPU Web-Server: Error message on page 'Protocol':
Two messages toggle in a slow cycle (1 minute):
 - Address Conflict: IP address conflict, defending IP address!
 - Address Conflict: No address conflict
 On each new detection of the address conflict the counter 'Address Conflict detection count' is incremented.

2.9 Addressing and Protocol selection 9442 CPUs

2.9.1 DP/RS485 + SB Address setting

A common station address is used from the 9442 CPU for the protocols PROFIBUS DP as well as the STAHL service bus via USB/RS485, which is adjustable via two rotary switches S2, S3 on the first IS1+ socket (Bank 0). The switch is located under the left CPU. This has the advantage that the switches can not accidentally be changed during operation. **Changed switch settings will be accepted after CPU boot only.**

Address Range (0 – 99)

Address = S2 x 10 + S3



MODBUS interface description

2.9.2 Protocol Selection

The required AS Protocol can be set by a rotary switch S1 on the IS1+ 9442 CPU socket. In case of CPU exchange this settings keep unchanged.

After changes of the selected Protocol, matching configuration and parameter data must be created and loaded to the IS1+ field station.

AS-Protocol	S1 Switch setting
Reserved	0
PROFIBUS PNO Red.	1
PROFIBUS Stahl Red. Addr. Offs. 1	2
PROFIBUS Stahl Red. Addr. Offs. 0	3
<i>Reserved</i> - PROFINET	4
<i>Reserved</i>	5
Modbus TCP	6
<i>Reserved</i> - EtherNet/IP	7
<i>Reserved</i>	8
<i>Reserved</i>	9

2.9.3 IP Address setting

Two separate IP addresses for the Ethernet communication are available for the 9442 IS1 CPU:

- IP-AS: Realtime bus to automation system (MODBUS TCP, PROFINET, EtherNet/IP,)
- IP-SB: Service Bus Functions: Web-Server, IS1 DTM, HART, Standard TCP Traffic, SW-Update

This separation of IP Addresses allows enhanced independence of the different data streams also if both data streams are transmitted via the same Ethernet ports. A change of IP addresses is blocked during active data exchange to the Automation System.

Caution! IP-AS and IP-SB addresses of a CPU must be unique as all IP addresses of an Ethernet network. The IP address information is stored in the socket backup memory as well. Configuration and address information of a IS1+ field station are therefore preserved in case of exchange of CPUs.

MODBUS interface description

2.9.3.1 IS1+ Detect

The 'IS1+ Detect' tool can scan the Ethernet Network for connected IS1+ field stations with 9442 CPUs and display the IP addresses of the found CPUs. This applies also to stations which are outside of the IP-addressable address range of the network.

IP-SB addresses of found IS1+ 9442 CPUs can be changed if necessary and must be inside of the IP-addressable address range of the network.

Thus the IS1+ CPUs are accessible via the integrated Web server. Diagnostic information can be displayed here and further adjustments can be made.

No.	CPU Ser. No.	MAC Address	Device Name	IP - SB	Subn. Mask	Def. Gatew.	DHCP	Protocol	IP-AS	SB / RS485 Addr	Type	Version
1	10001579636	00-1D-F7-02-00-28	Area 1_10	172.24.47.74	255.255.255.0	0.0.0.0	Disabled	ModbusTcp	172.24.47.75	16	9442/35-10-00	Rev A - V1.0.1
2	10001579635	00-1D-F7-02-00-46	Area 1_11	172.24.47.81	255.255.255.0	172.24.47.1	Disabled	ModbusTcp	172.24.47.82	5	9442/35-10-00	Rev A - V1.0.1
3	10001579638	00-1D-F7-02-00-4B		172.24.47.115	255.255.255.0	172.24.47.1	Enabled	Profibus 1		6	9442/35-10-00	Rev A - V1.0.1
4	10001579632	00-1D-F7-02-00-5A		172.24.47.145	255.255.255.0	172.24.47.1	Enabled	Profibus 1		2	9442/35-10-00	Rev A - V1.0.1
5	10001579636	00-1D-F7-02-00-3C		172.24.47.148	255.255.255.0	172.24.47.1	Enabled	Profibus 1		5	9442/35-10-00	Rev A - V1.0.1
6	10001579635	00-1D-F7-02-00-5F		172.24.47.178	255.255.255.0	172.24.47.1	Enabled	Profibus 1		1	9442/35-10-00	Rev A - V1.0.1

MODBUS interface description

2.9.3.2 IS1+ Web Server

The IP-AS address for the MODBUS TCP interface and the IP-SB Address can be adjusted via the Web server of 9442 CPU.

The IP-AS, IP-SB addresses and the Device Name of both CPUs (left - and right CPU) of a redundant pair are displayed in the IS1 Webserver while the Web server is connected with one of the two CPUs (connected).

The IP-SB as well as IP-AS address can only be changed in the CPU, with which the Web server is currently connected. A valid user login is required for change.

A manual change is only possible with a valid user login and without DataExchange with an MODBUS TCP client. DHCP must be disabled. An existing connection to the Web server is closed after a change of IP SB address and must be reopened to the modified IP SB address.

CPU 9442 - Left (connected)		CPU 9442 - Right	
	IP-AS	IP-SB	
Device Name:	-	-	-
IP-Address:	172.24.47.75	172.24.47.74	0.0.0.0
Subnet:	255.255.255.0	255.255.255.0	0.0.0.0
Default GW:	0.0.0.0	0.0.0.0	0.0.0.0
MAC Address:	00:1d:f7:02:00:28	00:1d:f7:02:00:2b	00:00:00:00:00:00

Service Bus / RS485 Addr.	16
AS Protocol	MODBUS TCP
SB-DHCP	Disable

Warning! Use for authorized personal only! Changing address data during operation may cause loss of concerned ethernet communication connections.

Buttons: **Accept changes** | **Refresh Data**

Further details see: [Webserver in IS1+ CPU](#)

MODBUS interface description

2.10 System start-up behavior

Using MODBUS TCP, configuration data and parameter data for CPU and all I/O modules are generated using the IS1 DTMs, transferred via Ethernet to the IS1+ field station by 'download' and are stored in non-volatile memory in the socket for the IS1 CPU.

Using MODBUS RTU configuration data and parameter data are generated with the IS Wizard Tool and transmitted via a RS485 / USB Service Bus.

After power on the entire data range of the output register is initialized with the value 0x8000. All output signals therefore remain in the safe setting.

The remaining data areas are initialized with 0x0000.

After power on the CPU checks that valid configuration data and parameter data are available.

Configuration data and parameter data	CPU state after checking and booting
No data available	No data exchange (3)
Data invalid (e.g. CRC error)	Config or parameter error (4)
Data valid	Data exchange with AS quit (5)

If valid data are available, the CPU remains in the state "No data exchange (after power on)", until a cyclic MODBUS connection is established.

If configuration and parameter data of both CPUs are different, the inactive CPU will go to the Config Error(4) state.

CPU Synchronisation

A non-redundant IS1 CPU can be started by establishing of any cyclic MODBUS connection.

Once a valid message is received, the CPU changes to the state "Data exchange with AS" and the I/O data are exchanged cyclically with the I/O modules configured. The MODBUS register can be accessed from the automation system (AS).

The output signals remain in safe setting until valid output data is written by the AS or by the IS1 DTMs.

Changing I/O modules during operation is possible. After plugging in a new module, parameters are automatically transferred from CPU to the I/O module, followed by a restart of the I/O module. -> Hot swap I/O module.

Exception: Module TIM R 9480/.. : The calibration value for 2 wire operation is stored in the I/O module. After changing of I/O modules a new calibration is required.

MODBUS interface description

2.11 MODBUS Functions

The IS1+ 9442 CPU acts as a MODBUS TCP server or a MODBUS RTU slave according the following specifications:

- MODBUS MESSAGING ON TCP/IP IMPLEMENTATION GUIDE V1.0b
- MODBUS APPLICATION PROTOCOL SPECIFICATION V1.1b

For details of protocol, MODBUS Functions, MODBUS-Error codes see above documents.

The following MODBUS functions are supported:

MODBUS Functions		Function in IS1+	PLC memory area *2)
01 (0x01)	Read Coils	• Read Discrete outputs	0xxxxx
02 (0x02)	Read Discrete Inputs		1xxxxx
03 (0x03)	Read Holding Registers	• Read output signals • Read input signals with register offset+1000	4xxxxx
04 (0x04)	Read Input Registers		3xxxxx
05 (0x05)	Write Single Coil *1)		
06 (0x06)	Write Single Register		
08 (0x08)	Diagnostics Subfunction 0x00 Return-Query Data	• Connection check (Function supported for MODBUS RTU only)	
15 (0x0F)	Write Multiple Coils		
16 (0x10)	Write Multiple Registers		
43 (0x2B)	Read Device Identification Read Device ID code = 01 / 02 / 04		

*1) On the usage of the **MODBUS function 5** (Write Single Coil) the following is to be noted:
After power on or after the loss of the data exchange, the value 0x8000 is written to the output registers in the IS1 CPU and thus the outputs changed to the safe setting. On the subsequent first write operation to such output registers, the complete register is to be overwritten the first time (e.g. using the MODBUS functions 6, 15 or 16) to set all output bits to a defined state. From then on individual bits can be changed using function 5.

*2) Some PLCs / MODBUS TCP clients allocate the Modbus Function indirect via selection of specific memory areas in the PLC. Details see operating instruction of PLC.

MODBUS interface description

2.11.1 MODBUS-FUNCTION 08 - Diagnostics

For MODBUS RTU the subfunction 0 (Return Query Data / LOOPBACK TEST) is supported. This function can be used to check the physical connection between master (client) and slave (server) without exchange of I/O data.

For MODBUS TCP this function is not supported according MODBUS specification.

2.11.2 MODBUS-FUNCTION 43 (0x2B) - Read Device Identification

Function Code: 0x2B
 MEI Type: 0x0E
 Read Device ID code: 0x01
 Object Id: 0x00

Object Id	Object Name / Description	Content	Type	category
0x00	VendorName	R. STAHL Schaltgeraete GmbH	ASCII String	Basic
0x01	ProductCode	9442/35-10-00		
0x02	MajorMinorRevision	Rev xx, V y.y.y *1)		
0x03	VendorUrl *3)	www.IS1easy.com		Regular
0x04	ProductName	IS1 Remote I/O System		
0x05	ModelName *3)	IS1 CPU		
0x80	Physical address *3)	Ethernet MAC address	6 Byte UINT8	Extended *2)
0x81	Serialnumber *3)	xxxxxxx-xxxx	ASCII String	

*1) Actual IS1 CPU revision: xx = Hardware Revision, Vy.y.y = Firmware Revision

*2) Access to Object Id 0x80 and 0x81 only with Device Id Code 4 (individual access) !

*3) Supported by 9441 CPUs only

Max. object length = 27 bytes

MODBUS interface description

2.11.3 MODBUS error codes

The error codes transmitted from IS1 to the MODBUS TCP clients in case of errors are according the MODBUS specification.

MODBUS error codes:

Error Code	Name	Possible Reason	Trouble shooting
0x01	Illegal Function	MODBUS function not implemented	Change MODBUS client message parameters .
0x02	Illegal Data Address	Access outside the MODBUS allowed register limits see: Rules for message processing:	Change MODBUS client message parameters.
0x03	Illegal Data Value	Error in the message structure	<ul style="list-style-type: none"> • Check quality of transmission on the MODBUS network • Check MODBUS client message parameters
0x04	Slave Device Failure	Hardware error CPU MODBUS memory error	Replace CPU
0x05	Acknowledge	Hardware error CPU (CPU state 1) Other hardware errors	Replace CPU
		No data exchange (CPU state 3) (after power on without config- and parameter data)	Download config- and parameter data via IS1 DTM into IS1 CPUs
		Configuration or parameter error (CPU state 4)	Check configuration and parameter settings and if necessary download the data via IS1 DTM.
0x06	Slave Device busy	CPU is busy	The client (or master) should retransmit the message later when the server (or slave) is free.
No Response	Timeout in Client	<ul style="list-style-type: none"> • Server (IS1 CPU) is not receiving a request • Server is receiving a request, but has detected a transmission error (parity, CRC) 	<ul style="list-style-type: none"> • Check transmission quality on the MODBUS network • Check parameter settings and function of the MODBUS client

For further information on MODBUS TCP error behavior see document “MODBUS Application Protocol Specification V1.1b (<http://www.modbus.org/>)

MODBUS interface description

2.11.4 MODBUS TCP Multi Client operation

The MODBUS TCP server in IS1 supports multi-client operation with parallel communication with several MODBUS TCP clients.

IS1 CPU	max. TCP Clients
9441	5
9442	10

- Input signals can be read by MODBUS TCP clients as required.
- Output signals are only allowed to be written by one client.
- This situation is not controlled by MODBUS mechanisms!



Attention!

It is the responsibility of the engineer planning the MODBUS TCP clients to ensure individual output signals are not overwritten by several MODBUS TCP clients.

If an output signal is written by several clients with different output values, the related output signal will toggle randomly between the values written.

Behavior in the case of the failure of cyclic MODBUS TCP connections:

Each of the client connections has a dedicated connection monitoring feature.

The time set as IS1 CPU parameter 'Watchdog time AS interface' applies globally to all connections.

After establishing a cyclic MODBUS connection, the CPU changes to the state 'Data Exchange'. This one connection is now monitored for cyclic data traffic for the time set.

Independent of this situation, the start condition can also be met on another connection, as a result the monitoring for cyclic data traffic is also started on this connection.

If the data exchange on one of the active connections is interrupted, the value 0x8000 is output on the entire output image for the IS1+ field station.

The output modules retain the previous output data from this point in time until the 'Output modules timeout' has elapsed.

If no new output data have arrived by this time, the output signals switch to the safe setting.

If, prior to the elapse of the 'Output modules timeout' parts of the output signals are overwritten with values other than 0x8000 via Modbus connections that are still established, this data is sent to the related outputs.

Only the data areas not updated change to the safe setting after the elapse of the 'Output modules timeout'.

CPU state

The state of the CPU is displayed in the diagnostics overview CPU in the IS1 DTMs:

CPU state			Behavior using MODBUS TCP multi client operation.
2	Data exchange with AS	active	State if one or more MODBUS clients are in data exchange
5	Data exchange with AS quit (Exchange with WIZARD/DTM is possible)	active	State if all MODBUS clients have quit data exchange

Detailed information on the status of the different client connections is also available via the webserver in IS1 CPU (see [Webserver in IS1 CPU](#)).

MODBUS interface description

3 Data traffic

3.1 Signal marshalling

The assignment of the signals of a fieldstation to the MODBUS registers results through an automatic block function for all signals.

Two different data structures are available in parallel which optionally can be used according AS requirements. Read data (Input- and Output data) are available in both structures in parallel. Data written to one of the structures will be transferred internally to the other structure.

Data structures	Signal status IS1+ IOM *1)	System Requirements
Input and Output Signal blocking	Yes, supported	all IS1 CPM and CPU Revisions
Signal Type blocking (DI, AI, HV, DO, AO)	Not mapped	Available for 9442 CPU and CPM 9440 from firmware V11-13

*1) Signal status via status code in the AI data register and status bits of all DI signals are available in both data structures.



Hint: A signal list with allocated MODBUS registers for a configured IS1 Fieldstation can be exported for both data structures as **.csv file** using the IS Wizard tool from Rev. 3.2.5.

Overview MODBUS Registers Areas and Functions:

Input and Output Signal blocking				Signal Type blocking															
F2 F4	F3		F3 F6, F16 F1, F15	F4 READ INPUT REGS DI only: F2 READ INPUT STATUS						F3 READ HOLDING REGS F6, F16 PRESET REGS DO only: F1, F15 R/W Coils									
Input Signals			Outp. Sign.	DI		AI		HV			DO		AO						
REG	REG	Data	REG	Data	REG		REG	Data	REG	Data	REG	Data	REG	Data					
13	-	Status Info	-	-	1001	DI Signals	2001	AI Signals	3001	HART Variable	Hv1	1501	DO Signals	2501	AO Signals				
...	...			1002	2002		3002		1502					2502					
31	-	Input Sig. + HV	32	Output Signals		3003		Hv2
32	1032		33		1160		2128		3004			1564		2596					
33	1033					
431	1431		431					3254	Hv x										
							3255												

Register Area	Extended HART Data
5001 – 6536	HART Variablen + DV Status
6601 – 6616	HART Livelist
6617 – 6744	DEVSTATUS - HART Device Status
6745 – 6872	HART Extended Device Status
7001 – 7512	HART UNIT CODE

Details see [HART variables](#)

MODBUS interface description

3.1.1 Input and Output Signal blocking

Separately for the input and the output area the signals of the IO modules are put to data blocks, starting with the slot 1 on a defined MODBUS Startaddress, according the row of the I/O modules. This process has the advantage, that all data can be read and/or written in one telegram, where the result is an efficient data transmission with a minimum of protocol overhead.

The following table shows the data length of the individual I/O module types.

Module selection in IS1 DTM or in IS Wizard	Data length [Registers]		IOM Type
	Input	Output	
9460/12-08-11 AIM 4/8 Exi	8	-	IS1
9461/12-08-11 AIMH8 2w Exi	8	-	
9461/12-08-11 AIMH8+4HV 2w Exi	16	-	
9461/12-08-11 AIMH8+8HV 2w Exi	24	-	
9461/12-08-21 AIMH 8 Exi	8	-	
9461/12-08-21 AIMH 8 +4HV Exi	16	-	
9461/12-08-21 AIMH 8 +8HV Exi	24	-	
9461/15-08-12 AIMH8 2w Exn	8	-	
9461/15-08-12 AIMH8+4HV 2w Exn	16	-	
9461/15-08-12 AIMH8+8HV 2w Exn	24	-	
9462/... SAIMH	Usable with PROFIBUS and PROFIsafe only		
9465/12-08-11 AOM 8 Exi	-	8	
9466/12-08-11 AOMH 8 Exi	-	8	
9466/12-08-11 AOMH 8 +4HV Exi	8	8	
9466/12-08-11 AOMH 8 +8HV Exi	16	8	
9466/15-08-12 AOMH 8 Exn	-	8	
9466/15-08-12 AOMH 8+4HV Exn	8	8	
9466/15-08-12 AOMH 8+8HV Exn	16	8	
9468/3x-08-xx 8AIH	9	0	IS1+
9468/3x-08-xx 8AOH	1	8	
9468/3x-08-xx 6AIH+2AOH	7	2	
9468/3x-08-xx 8AIH/8AOH	9	8	
9468/3x-08-xx 8AIH +4HV	17	0	
9468/3x-08-xx 8AOH +4HV	9	8	
9468/3x-08-xx 8AIH/8AOH +4HV	17	8	
9468/3x-08-xx 8AIH +8HV	25	0	
9468/3x-08-xx 8AOH +8HV	17	8	
9468/3x-08-xx 8AIH/8AOH +8HV	25	8	
9469/35-08-xx 8IH Exn	9	0	
9469/35-08-xx 8OH Exn	1	8	
9469/35-08-xx 6IH+2OH Exn	7	2	
9469/35-08-xx 8IH/8OH Exn	9	8	
9469/35-08-xx 8IH +4HV Exn	17	0	
9469/35-08-xx 8OH +4HV Exn	9	8	
9469/35-08-xx 8IH/8OH +4HV Exn	17	8	
9469/35-08-xx 8IH +8HV Exn	25	0	
9469/35-08-xx 8OH +8HV Exn	17	8	
9469/35-08-xx 8IH/8OH +8HV Exn	25	8	
9470/22-16-11 DIM 16 NamExi	2	-	IS1
9470/22-16-11 DIM 16+CF NamExi	4	1	
9470/25-16-12 DIM16 Nam Exn	2	-	
9470/25-16-12 DIM16+CF Nam Exn	4	1	

MODBUS interface description

Module selection in IS1 DTM or in IS Wizard	Data length [Registers]		IOM Type
	Input	Output	
9470/3x-16-xx DIM 16	2	0	IS1+
9470/3x-16-xx DI/DO 16	2	2	
9470/3x-16-xx DI/DO 16+2CF	4	4	
9470/3x-16-xx DI/DO 16+6CF	8	4	
9470/3x-16-xx DI/DO 16+8CF	10	4	
9471/10-16-11 DIM 16 24V	2	-	IS1
9471/10-16-11 DIM 16+CF 24V	4	1	
9471/15-16-12 DIM 16 24V Exn	2	-	
9471/15-16-12 DIM 16+CF24V Exn	4	1	
9471/35-16-xx DIM 16 Exn	2	0	IS1+
9471/35-16-xx DI/DO 16 Exn	2	1	
9471/35-16-xx DI/DO 16+2CF Exn	4	2	
9471/35-16-xx DI/DO 16+6CF Exn	8	2	
9471/35-16-xx DI/DO 16+8CF Exn	10	2	
9472/35-16-xx DIM 16 24V Exn	2	0	
9472/35-16-xx DI/DO 24V Exn	2	1	
9472/35-16-xx DI/DO 24V+2CF Exn	4	2	
9472/35-16-xx DI/DO 24V+6CF Exn	8	2	
9472/35-16-xx DI/DO 24V+8CF Exn	10	2	
9475/12-04-11 DOM 4 Exi1	-	1	IS1
9475/12-04-21 DOM 4 Exi2	-	1	
9475/12-04-31 DOM 4 Exi3	-	1	
9475/12-08-41 DOM 8 Exi1	-	1	
9475/12-08-51 DOM 8 Exi2	-	1	
9475/12-08-61 DOM 8 Exi3	-	1	
9475/12-07-71 DOM 7 Exi4	-	1	
9475/22-04-21 DOM 4 OD Exi2	-	1	
9475/22-08-51 DOM 8 OD Exi2	-	1	
9475/22-08-61 DOM 8 OD Exi3	-	1	
9475/3x-04-xx DOM 4	1	1	IS1+
9475/3x-08-xx DOM 8	1	1	
9477/10-08-12 DOM 8 Rel	-	1	IS1
9477/12-08-12 DOM 8 60V Rel Z1	-	1	
9477/12-06-12 DOM 6 250V Rel Z1	-	1	
9477/15-08-12 DOM 8 Rel Z2	-	1	
9478/22-08-51 DOMV8 OD Exi1	-	1	
9480/12-08-11 TIM 8 R Exi	8	-	
9481/12-08-11 TIM 8 mV Exi	8	-	IS1+
9482/3x-08-xx 8TIM	9	0	
AIM 4/8 (9460/..., 9461/..)	8	-	
AOM 8 (9465/..., 9466/..)	-	8	
DIM 16 (9470/..., 9471/..)	1	-	
DOM 4/8 (9475/..)	-	1	-

MODBUS interface description

3.1.1.1 Register allocation of I/O data

Two **separate memory areas** are available for input and output data. The read access to this memory areas can be selected via the different MODBUS functions.

Input signals (DI / AI):

	MODBUS address on interface *2)		MODBUS address in AS and IS1 DTM		Content	Allowed MODBUS functions
	Register Address	Bit (Coil) Address	Register Address	Bit (Coil) Address *1)		
Input data	0x000c (12)	0x00c0 (192)	0x000d (13)	0x00c1 (193)	Signal statuses 1 register per module 1 bit per signal	read: 02 (input coil) or 04 (input register)
	0x001b (27)	0x01b0 (432)	0x001c (28)	0x01b1 (433)		
	0x001c (28)	0x01c0 (448)	0x001d (29)	0x01c1 (449)	Module alarms slot 0 to 15	optional: 03 (holding register) with Register offset +1000
	0x001d (29)	0x01d0 (464)	0x001e (30)	0x01d1 (465)	Module alarms slot 16	
	0x001e (30)	0x01e0 (480)	0x001f (31)	0x01e1 (481)	Status register CPU	
	0x001f (31)	0x01f0 (496)	0x0020 (32)	0x01f1 (497)	Data block input signals	
		
0x01ae (430)	0x1aef (6895)	0x01af (431)	0x1af0 (6896)			

Output signals (DO / AO):

	MODBUS Address on interface *2)		MODBUS Address in AS and IS1 DTM		Content	Allowed MODBUS functions
	Register Address	Bit (Coil) Address	Register Address	Bit (Coil) Address *1)		
Output data	0x001e (30)	0x01e0 (480)	0x001f (31)	0x01e1 (481)	Control register CPU	read: 01 (output coil) 03 (holding register)
	0x001f (31)	0x01f0 (496)	0x0020 (32)	0x01f1 (497)	Data block output signals	
	0x01ae (430)	0x1aef (6895)	0x01af (431)	0x1af0 (6896)		write: 05, 15 (coil) 06, 16 (register)

*1): The MODBUS functions 01, 02, 05 and 15 use coil addresses. The MODBUS functions 03, 04, 06 and 16 use register addresses.

Rule for the least significant bit of a register: **Coil address = (Register address - 1) * 16 + 1**

*2): **Attention!**

In the data telegrams on the interfaces a Register/Coil address decremented by '1' is transmitted from IS1 according MODBUS specification. Some automation systems show the same addresses in the software as they are on the interfaces. In this case the Register- and Coil addresses of the IS1 system must be decremented by one for use in the automation system.

MODBUS interface description

Example:

An IS1+ field station is used with the following modules:

Module type:	CPU	DIM16	DIM 16 + CF	DOM 8	AIM 8	AOM 8
Slot:	0	1	2	3	4	5

With this configuration the register address allocations to the signals are as follows:

Input signals			MODBUS address		
Slot	Module type	Signals	Read Register M. Function 4	Read Register M. Function 3	Read Coil M. Function 2
1	DIM 16	DI 0 ... DI 15	32	1032	497 – 512
		Status 0 ... 15	33	1033	513 – 528
2	DIM 16 + CF	DI 0 ... DI 15	34	1034	529 – 544
		Status 0 ... 15	35	1035	545 – 560
		Counter / freq. input 14	36	1036	561 – 576
		Counter / freq. input 15	37	1037	577 – 592
4	AIM	AI 0	38	1038	
		AI 1	39	1039	
		AI 2	40	1040	
		AI 3	41	1041	
		AI 4	42	1042	
		AI 5	43	1043	
		AI 6	44	1044	
		AI 7	45	1045	

Output signals			MODBUS address (read with MODBUS functions 1 or 3, write with MODBUS functions 6, 15 or 16)	
Slot	Module type	Signals	Register read / write	Coil
2	DIM16 + CF	Control register for counter	32	497 – 512
3	DOM 8	DO 0 ... DO 7	33	513 – 528
5	AOM	AO 0	34	
		AO 1	35	
		AO 2	36	
		AO 3	37	
		AO 4	38	
		AO 5	39	
		AO 6	40	
		AO 7	41	

MODBUS interface description

3.1.2 Signal Type blocking (DI, AI, HV, DO, AO)

Separately for the signal types DI, AI, HV (HART Variable), DO and AO the signals of the IO modules are grouped to data blocks, starting with the slot 1 on a defined MODBUS Startaddress, according the row of the I/O modules. This process has the advantage, that all data of the same signal type can be read and/or written in one telegram, where the result is an efficient data transmission with a minimum of protocol overhead. The following table shows the data length and allocation to the different signal types of the individual I/O module types.

Module Type and Description	F4 READ INPUT REGISTERS DI only: F2 READ INPUT STATUS						F3 READ HOLDING REGISTERS F6, F16 PRESET MULTIPLE REGS DO only: F1, F15 R/W Coils			
	from Reg. 1001 (1000)		from Reg. 2001 (2000)		from Reg. 3001 (3000)		from Reg. 1501 (1500)		from Reg. 2501 (2500)	
	DI	Num. Reg.	AI	Num. Reg.	HV	Num. Reg.	DO	Num. Reg.	AO	Num. Reg.
9460/12-08-11 AIM 4/8 Exi	.	.	8AI	8
9460/12-08-12 AIM 4/8	.	.	8AI	8
9461/12-08-11 AIMH8 2w Exi	.	.	8AI	8
9461/12-08-11 AIMH8+4HV 2w Exi	.	.	8AI	8	4HV	8
9461/12-08-11 AIMH8+8HV 2w Exi	.	.	8AI	8	8HV	16
9461/15-08-12 AIMH8 2w Exn	.	.	8AI	8
9461/15-08-12 AIMH8+4HV 2w Exn	.	.	8AI	8	4HV	8
9461/15-08-12 AIMH8+8HV 2w Exn	.	.	8AI	8	8HV	16
9461/12-08-21 AIMH 8 Exi	.	.	8AI	8
9461/12-08-21 AIMH 8+4HV Exi	.	.	8AI	8	4HV	8
9461/12-08-21 AIMH 8+8HV Exi	.	.	8AI	8	8HV	16
9461/15-08-22 AIMH 8 Z2	.	.	8AI	8
9465/12-08-11 AOM 8 Exi	8AO	8
9465/15-08-12 AOM 8 Z2	8AO	8
9466/12-08-11 AOMH 8 Exi	8AO	8
9466/12-08-11 AOMH 8+4HV Exi	4HV	8	.	.	8AO	8
9466/12-08-11 AOMH 8+8HV Exi	8HV	16	.	.	8AO	8
9466/15-08-12 AOMH 8 Exn	8AO	8
9466/15-08-12 AOMH 8+4HV Exn	4HV	8	.	.	8AO	8
9466/15-08-12 AOMH 8+8HV Exn	8HV	16	.	.	8AO	8
9468(69)/3x-08-xx 8AIH	.	.	8AI	8
9468(69)/3x-08-xx 8AOH	8AO	8
9468(69)/3x-08-xx 6AIH+2AOH	.	.	6AI	6	2AO	2
9468(69)/3x-08-xx 8AIH/8AOH	.	.	8AI	8	8AO	8
9468(69)/3x-08-xx 8AIH +4HV	.	.	8AI	8	4HV	8
9468(69)/3x-08-xx 8AOH +4HV	4HV	8	.	.	8AO	8
9468(69)/3x-08-xx 8AIH/8AOH +4HV	.	.	8AI	8	4HV	8
9468(69)/3x-08-xx	.	.	8AI	8	8HV	16

MODBUS interface description

8AIH +8HV										
9468(69)/3x-08-xx 8AOH +8HV	8HV	16	.	.	8AO	8
9468(69)/3x-08-xx 8AIH/8AOH +8HV	.	.	8AI	8	8HV	16	.	.	8AO	8
9470/12-16-11 DIM 16 NamExi	DI ST	2
9470/22-16-11 DIM 16 NamExi	DI ST	2
9470/22-16-11 DIM 16+CF NamExi	DI ST 2CF	4	DO CR	1	.	.
9470/25-16-12 DIM16 Nam Exn	DI ST	2
9470/25-16-12 DIM16+CF Nam Exn	DI ST 2CF	4	DO CR	1	.	.

AI	Analog Input
AO	Analog Output
DI ST 2CF	Digital Input, Status, Counter Fre- quency

DO	Digital Output
CR	Counter Reset, Start, Stop
HV	HART Variable

Module Type and Description	F4 READ INPUT REGISTERS DI only: F2 READ INPUT STATUS						F3 READ HOLDING REGIS- TERS F6, F16 PRESET MULTIPLE REGS DO only: F1, F15 RW Coils			
	from Reg. 1001 (1000)		from Reg. 2001 (2000)		from Reg. 3001 (3000)		from Reg. 1501 (1500)		from Reg. 2501 (2500)	
	DI	Num. Reg.	AI	Num. Reg.	HV	Num. Reg.	DO	Num. Reg.	AO	Num. Reg.
9470/3x-16-xx DIM 16	DI ST	2
9470/3x-16-xx DI/DO 16	DI ST	2	16DO	2	.	.
9470/3x-16-xx DI/DO 16+2CF	DI ST 2CF	4	16DO CR	4	.	.
9470/3x-16-xx DI/DO 16+2CF	DI ST 2CF	4	16DO CR	4	.	.
9470/3x-16-xx DI/DO 16+6CF	DI ST 6CF	8	16DO CR	4	.	.
9470/3x-16-xx DI/DO 16+8CF	DI ST 8CF	10	16DO CR	4	.	.
9471/10-16-11 DIM 16 24V	DI ST	2
9471/10-16-11 DIM 16+CF 24V	DI ST 2CF	4	DO CR	1	.	.
9471/15-16-12 DIM16 24V Exn	DI ST	2
9471/15-16-12 DIM16+CF 24V Exn	DI ST 2CF	4	DO CR	1	.	.
9471/12-16-11 DIM 16 24VExi	DI ST	2
9471/12-16-11 DIM 16+CF 24VExi	DI ST 2CF	4	DO CR	1	.	.
9471/35-16-xx DIM 16 Exn	DI ST	2
9471/35-16-xx DI/DO 16 Exn	DI ST	2	16DO	2	.	.
9471/35-16-xx DI/DO 16+2CF Exn	DI ST 2CF	4	16DO CR	4	.	.
9471/35-16-xx DI/DO 16+6CF Exn	DI ST 6CF	8	16DO CR	4	.	.
9471/35-16-xx DI/DO 16+8CF Exn	DI ST 8CF	10	16DO CR	4	.	.
9472/35-16-xx DIM 16 Exn	DI ST	2
9472/35-16-xx DI/DO 24V Exn	DI ST	2	16DO	2	.	.
9472/35-16-xx DI/DO 24V+2CF	DI ST	4	16DO	4	.	.

MODBUS interface description

Exn	2CF						CR			
9472/35-16-xx DI/DO 24V+6CF Exn	DI ST 6CF	8	16DO CR	4	.	.
9472/35-16-xx DI/DO 24V+8CF Exn	DI ST 8CF	10	16DO CR	4	.	.
9475/12-04-11 DOM 4 Exi1	4DO	1	.	.
9475/12-04-21 DOM 4 Exi2	4DO	1	.	.
9475/12-04-31 DOM 4 Exi3	4DO	1	.	.
9475/15-04-22 DOM 4 Z2	4DO	1	.	.
9475/12-08-41 DOM 8 Exi1	8DO	1	.	.
9475/12-08-51 DOM 8 Exi2	8DO	1	.	.
9475/12-08-61 DOM 8 Exi3	8DO	1	.	.
9475/22-04-21 DOM 4 OD Exi2	4DO	1	.	.
9475/22-08-51 DOM 8 OD Exi2	8DO	1	.	.
9475/22-08-61 DOM 8 OD Exi3	8DO	1	.	.
9475/3x-04-xx DOM 4	4DO	1	.	.
9475/3x-08-xx DOM 8	8DO	1	.	.
9477/10-08-12 DOM 8 Rel	8DO	1	.	.
9477/12-08-12 DOM 8 60V Rel Z1	8DO	1	.	.
9477/12-06-12 DOM 6 250V Rel Z1	6DO	1	.	.
9477/15-08-12 DOM 8 Rel Z2	8DO	1	.	.
9478/22-08-51 DOMV8 OD Exi1	8DO	1	.	.
9480/12-08-11 TIM 8 R Exi	.	.	8AI	8
9480/15-08-12 TIM 8 R Z2	.	.	8AI	8
9481/12-08-11 TIM 8 mV Exi	.	.	8AI	8
9481/15-08-12 TIM 8 mV Z2	.	.	8AI	8
9482/3x-08-xx 8TIM	.	.	8AI	8

MODBUS interface description

3.1.3 Configuration example IS1 Fieldstation

In- and Out Signal blocking				Signal type blocking															
F2 F4		F3		F3 F6, F16 F1, F15		F4 READ INPUT REGS DI only: F2 READ INPUT STATUS												F3 READ HOLDING REGS F6, F16 PRESET REGS DO only: F1, F15 R/W Coils	
IN Regs.				OUT Regs		DI			AI			HV			DO		AO		
REG	REG		IOM	REG	IOM	REG		IOM	REG		IOM	REG		IOM	REG	IOM	REG	IOM	
32	1032	DI	1	32	2	1001	DI	1	2001	AI_0	5	3001	Hv1	7	1501	2	2501	6	
33	1033	St		33		1002	St		2002	AI_1		3002			1502		2502		
34	1034	DI		34	3	1003	DI		2003	AI_2		3003	Hv2		1503	3	2503		
35	1035	St		35		1004	St		2004	AI_3		3004			1504		2504		
36	1036	CF1	2	36		1005	CF1	2	2005	AI_4	5	3005	Hv3	7	1505		2505		
37	1037	CF2		37	4	1006	CF2		2006	AI_5		3006			1506	4	2506		
38	1038	DI		38		1007	DI		2007	AI_6		3007	Hv4		1507	-	2507		
39	1039	St	3	39		1008	St	3	2008	AI_7		3008			1508	-	2508		
40	1040	CF1		40		1009	CF1		2009	AI_0		3009	Hv1	8	1509	-	2509		
41	1041	CF2		41	6	1010	CF2		2010	AI_1		3010			1510	-	2510		
42	1042	St	4	42		1011	-	-	2011	AI_2		3011	Hv2		1511	-	2511		
43	1043	AI_0		43		1012	-	-	2012	AI_3	7	3012			1512	-	2512		
44	1044	AI_1		44		1013	-	-	2013	AI_4		3013	Hv3		1513	-	2513		
45	1045	AI_2		45		1014	-	-	2014	AI_5		3014			1514	-	2514		
46	1046	AI_3	5	46		1015	-	-	2015	AI_6		3015	Hv4		1515	-	2515		
47	1047	AI_4		47		1016	-	-	2016	AI_7		3016			1516	-	2516		
48	1048	AI_5		48		1017	-	-	2017	AI_0		3017	-	-	1517	-	2517	-	
49	1049	AI_6		49		1018	-	-	2018	AI_1		3018	-	-	1518	-	2518	-	
50	1050	AI_7		50	8	1019	-	-	2019	AI_2		3019	-	-	1519	-	2519	-	
51	1051	St		51		1020	-	-	2020	AI_3	9	3020	-	-	1520	-	2520	-	
52	1052	St	6	52		1021	-	-	2021	AI_4		3021	-	-	1521	-	2521	-	
53	1053	AI_0		53		1022	-	-	2022	AI_5		3022	-	-	1522	-	2522	-	
54	1054	AI_1		54	-	1023	-	-	2023	AI_6		3023	-	-	1523	-	2523	-	
55	1055	AI_2		55	-	1024	-	-	2024	AI_7		3024	-	-	1524	-	2524	-	
56	1056	AI_3		56	-	1025	-	-	2025	-	-	3025	-	-	1525	-	2525	-	
57	1057	AI_4		57	-	1026	-	-	2026	-	-	3026	-	-	1526	-	2526	-	
58	1058	AI_5		58	-	1027	-	-	2027	-	-	3027	-	-	1527	-	2527	-	
59	1059	AI_6		...	-	...	-	-	...	-	-	...	-	-	...	-	...	-	
60	1060	AI_7		...	-	...	-	-	...	-	-	...	-	-	...	-	...	-	
61	1061	St	7																
62	1062																		
63	1063	Hv1																	
64	1064	Hv2																	
65	1065																		
66	1066	Hv3																	
67	1067																		
68	1068	Hv4																	
69	1069																		
70	1070	St																	
71	1071	Hv1																	
72	1072																		
73	1073	Hv2	8																
74	1074																		
75	1075	Hv3																	
76	1076																		
77	1077	Hv4																	
78	1078																		
79	1079	AI_0																	
80	1080	AI_1																	
81	1081	AI_2																	
82	1082	AI_3																	
83	1083	AI_4	9																
84	1084	AI_5																	
85	1085	AI_6																	
86	1086	AI_7																	
87	1087	St																	

Sample configuration IS1 Fieldstation:

IOM slot	Modul type	Num. Register	
		INP	OUT
1	DIM 16	2	0
2	DIM 16 CF	4	1
3	DIOM DI/DO 16+2CF	4	4
4	DOM 8 with Status	1	1
5	AUMH 8 AIH with Status	9	0
6	AUMH 8 AOH with Status	1	8
7	AUMH 8 AIH + 4HV with Status	17	0
8	AUMH 8AO + 4HV with Status	9	8
9	8TIM with Status	9	0

MODBUS interface description

3.1.4 Rules for message processing:

MODBUS register limits

	Input Data Read with F2 or F4 [Reg. Addr.]	Output Data Read with F1 or F3 Write with F6, F15, F16 [Reg. Address]	[Coil Address]
Status Info	13 – 31	-	193 – 496
Input Signals + HV	32– 431	-	497 – 6896
		1032 – 1431	-
Output Signals	-	32 – 431	497 – 6896
DI Signal Typ blocked	1001 – 1160		-
AI Signal Typ blocked	2001 – 2128		
HV Signal Typ blocked	3001 – 3255		
DO Signal Typ blocked		1501 – 1564	
AO Signal Typ blocked		2501 – 2596	
HART Variables + DV Status	5001 – 6536		
HART Livelist	6601 – 6616		
HART Device Status	6617 – 6744		
HART Extended Device Status	6745 – 6872		
HART UNIT CODE	7001 – 7512		

Accesses outside the a. m. MODBUS register limits are acknowledged with the error message 0x02 'Illegal Data Address'.

- Register areas not configured:
Write messages to register areas not configured are accepted and these data transferred to the register. These data can also be read back. The data are not allocated to the I/O signals on the modules.
- Read and write messages are only processed in CPM state 2 (Data exchange with AS (config + parameters from IS1 DTMs)) and CPM state 5 (left data exchange with AS).
In all other CPM states the error code 0x05 'Acknowledge' is returned.
See also '[MODBUS error codes](#)'

Exception: Read access to the status register (reg. 31 input) and write-read access to the control register (reg. 31 output) are always possible.

- For bit-access functions write and read access is possible without consideration of the register limits.
However, it is to be noted:
After power on or after the loss of the data exchange due to a client in the data exchange, the value 0x8000 is written to the output registers in the IS1 CPU and thus all outputs on the module placed in the safe setting. On writing to such an output register next time, the entire register is to be overwritten the first time (e.g. using the MODBUS functions 6, 15 or 16) to place all output bits in a defined state. From then on changes to the individual bits can be updated using function 5.
- A redundant CPU can also be started using start condition 'Write message' by a write message to the control register or an output area that is not configured.
- **Address on interface = address in the AS - 1**
(This is a generally valid MODBUS rule for coil and register addresses)



see [Register allocation of I/O data](#) hint 2 !

- Maximum telegram length = 125 Register according MODBUS TCP Spec.

MODBUS interface description

3.1.5 Extract from the allocation table

No.	Address	
	Reg.	Coil
1	32	497 - 512
2	33	513 - 528
3	34	529 - 544
4	35	545 - 560
5	36	561 - 576
6	37	577 - 592
7	38	593 - 608
8	39	609 - 624
9	40	625 - 640
10	41	641 - 656
11	42	657 - 672
12	43	673 - 688
13	44	689 - 704
14	45	705 - 720
15	46	721 - 736
16	47	737 - 752
17	48	753 - 768
18	49	769 - 784
19	50	785 - 800
20	51	801 - 816
21	52	817 - 832
22	53	833 - 848
23	54	849 - 864
24	55	865 - 880
25	56	881 - 896
26	57	897 - 912
27	58	913 - 928
28	59	929 - 944
29	60	945 - 960
30	61	961 - 976
31	62	977 - 992
32	63	993 - 1008
33	64	1009 - 1024
34	65	1025 - 1040
35	66	1041 - 1056
36	67	1057 - 1072
37	68	1073 - 1088
38	69	1089 - 1104
39	70	1105 - 1120
40	71	1121 - 1136
41	72	1137 - 1152
42	73	1153 - 1168
43	74	1169 - 1184
44	75	1185 - 1200
45	76	1201 - 1216
46	77	1217 - 1232
47	78	1233 - 1248
48	79	1249 - 1264
49	80	1265 - 1280
50	81	1281 - 1296
51	82	1297 - 1312
52	83	1313 - 1328
53	84	1329 - 1344
54	85	1345 - 1360
55	86	1361 - 1376
56	87	1377 - 1392
57	88	1393 - 1408
58	89	1409 - 1424
59	90	1425 - 1440
60	91	1441 - 1456
61	92	1457 - 1472
62	93	1473 - 1488
63	94	1489 - 1504
64	95	1505 - 1520

No.	Address	
	Reg.	Coil
65	96	1521 - 1536
66	97	1537 - 1552
67	98	1553 - 1568
68	99	1569 - 1584
69	100	1585 - 1600
70	101	1601 - 1616
71	102	1617 - 1632
72	103	1633 - 1648
73	104	1649 - 1664
74	105	1665 - 1680
75	106	1681 - 1696
76	107	1697 - 1712
77	108	1713 - 1728
78	109	1729 - 1744
79	110	1745 - 1760
80	111	1761 - 1776
81	112	1777 - 1792
82	113	1793 - 1808
83	114	1809 - 1824
84	115	1825 - 1840
85	116	1841 - 1856
86	117	1857 - 1872
87	118	1873 - 1888
88	119	1889 - 1904
89	120	1905 - 1920
90	121	1921 - 1936
91	122	1937 - 1952
92	123	1953 - 1968
93	124	1969 - 1984
94	125	1985 - 2000
95	126	2001 - 2016
96	127	2017 - 2032
97	128	2033 - 2048
98	129	2049 - 2064
99	130	2065 - 2080
100	131	2081 - 2096
101	132	2097 - 2112
102	133	2113 - 2128
103	134	2129 - 2144
104	135	2145 - 2160
105	136	2161 - 2176
106	137	2177 - 2192
107	138	2193 - 2208
108	139	2209 - 2224
109	140	2225 - 2240
110	141	2241 - 2256
111	142	2257 - 2272
112	143	2273 - 2288
113	144	2289 - 2304
114	145	2305 - 2320
115	146	2321 - 2336
116	147	2337 - 2352
117	148	2353 - 2368
118	149	2369 - 2384
119	150	2385 - 2400
120	151	2401 - 2416
121	152	2417 - 2432
122	153	2433 - 2448
123	154	2449 - 2464
124	155	2465 - 2480
125	156	2481 - 2496
126	157	2497 - 2512
127	158	2513 - 2528
128	159	2529 - 2544

No.	Address	
	Reg.	Coil
129	160	2545 - 2560
130	161	2561 - 2576
131	162	2577 - 2592
132	163	2593 - 2608
133	164	2609 - 2624
134	165	2625 - 2640
135	166	2641 - 2656
136	167	2657 - 2672
137	168	2673 - 2688
138	169	2689 - 2704
139	170	2705 - 2720
140	171	2721 - 2736
141	172	2737 - 2752
142	173	2753 - 2768
143	174	2769 - 2784
144	175	2785 - 2800
145	176	2801 - 2816
146	177	2817 - 2832
147	178	2833 - 2848
148	179	2849 - 2864
149	180	2865 - 2880
150	181	2881 - 2896
151	182	2897 - 2912
152	183	2913 - 2928
153	184	2929 - 2944
154	185	2945 - 2960
155	186	2961 - 2976
156	187	2977 - 2992
157	188	2993 - 3008
158	189	3009 - 3024
159	190	3025 - 3040
160	191	3041 - 3056
161	192	3057 - 3072
162	193	3073 - 3088
163	194	3089 - 3104
164	195	3105 - 3120
165	196	3121 - 3136
166	197	3137 - 3152
167	198	3153 - 3168
168	199	3169 - 3184
169	200	3185 - 3200
170	201	3201 - 3216
171	202	3217 - 3232
172	203	3233 - 3248
173	204	3249 - 3264
174	205	3265 - 3280
175	206	3281 - 3296
176	207	3297 - 3312
177	208	3313 - 3328
178	209	3329 - 3344
179	210	3345 - 3360
180	211	3361 - 3376
181	212	3377 - 3392
182	213	3393 - 3408
183	214	3409 - 3424
184	215	3425 - 3440
185	216	3441 - 3456
186	217	3457 - 3472
187	218	3473 - 3488
188	219	3489 - 3504
189	220	3505 - 3520
190	221	3521 - 3536
191	222	3537 - 3552
192	223	3553 - 3568

No.	Address	
	Reg.	Coil
193	224	3569 - 3584
194	225	3585 - 3600
195	226	3601 - 3616
196	227	3617 - 3632
197	228	3633 - 3648
198	229	3649 - 3664
199	230	3665 - 3680
200	231	3681 - 3696
201	232	3697 - 3712
202	233	3713 - 3728
203	234	3729 - 3744
204	235	3745 - 3760
205	236	3761 - 3776
206	237	3777 - 3792
207	238	3793 - 3808
208	239	3809 - 3824
209	240	3825 - 3840
210	241	3841 - 3856
211	242	3857 - 3872
212	243	3873 - 3888
213	244	3889 - 3904
214	245	3905 - 3920
215	246	3921 - 3936
216	247	3937 - 3952
217	248	3953 - 3968
218	249	3969 - 3984
219	250	3985 - 4000
220	251	4001 - 4016
221	252	4017 - 4032
222	253	4033 - 4048
223	254	4049 - 4064
224	255	4065 - 4080
225	256	4081 - 4096
226	257	4097 - 4112
227	258	4113 - 4128
228	259	4129 - 4144
229	260	4145 - 4160
230	261	4161 - 4176
231	262	4177 - 4192
232	263	4193 - 4208
233	264	4209 - 4224
234	265	4225 - 4240
235	266	4241 - 4256
236	267	4257 - 4272
237	268	4273 - 4288
238	269	4289 - 4304
239	270	4305 - 4320
240	271	4321 - 4336
241	272	4337 - 4352
242	273	4353 - 4368
243	274	4369 - 4384
244	275	4385 - 4400
245	276	4401 - 4416
246	277	4417 - 4432
247	278	4433 - 4448
248	279	4449 - 4464
249	280	4465 - 4480
250	281	4481 - 4496
251	282	4497 - 4512
252	283	4513 - 4528
253	284	4529 - 4544
254	285	4545 - 4560
255	286	4561 - 4576
256	287	4577 - 4592

Rule for the least significant bit of a register: **Coil address = (Register address - 1) * 16 + 1**

MODBUS interface description

3.2 Status register CPU

Through the status register the actual status of the CPU (both CPUs in redundant operation) can be read:

Low Byte:

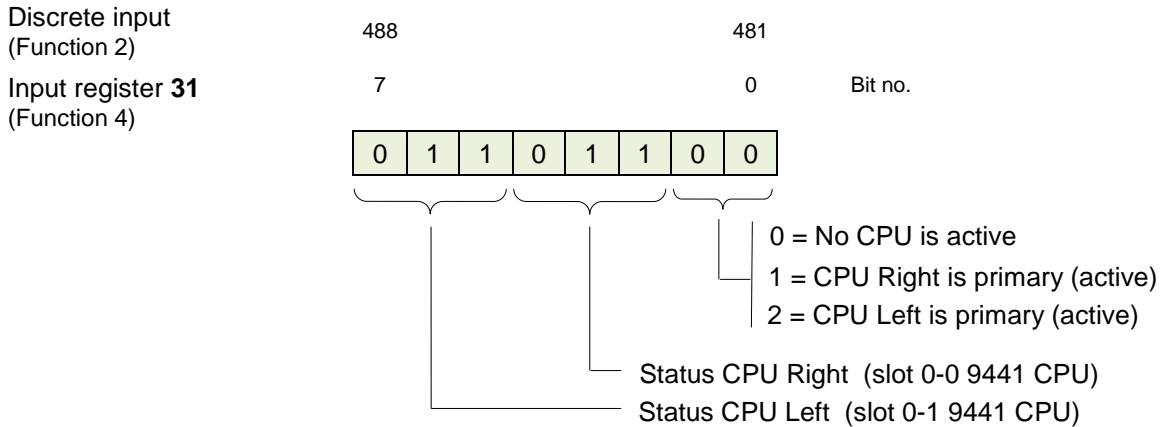

Left and Right CPM are exchanged using 9440 CPM !

Status CPU:

Value	Function	Measure / Remedy	
value 0 (000)	Reserved	-	-
value 1 (001)	Hardware error CPM	Exchange CPM	
value 2 (010)	Data Exchange with AS (Config + Parameter from IS1 DTM)	Check status information for monitoring	
value 3 (011)	No data exchange (after power on without config- and parameter data)	Download config. and parameter data to IS1 CPU. Start up data exchange from master.	
value 4 (100)	Configuration- or Parameter failure	Check config. and parameter data in IS1 DTM	
value 5 (101)	Data exchange with AS quit (as well after PowerOn, if config- and parameter data are valid)	Check bus connection to AS. Start up data exchange from master	
value 6 + 7	Reserved	-	-

High Byte:

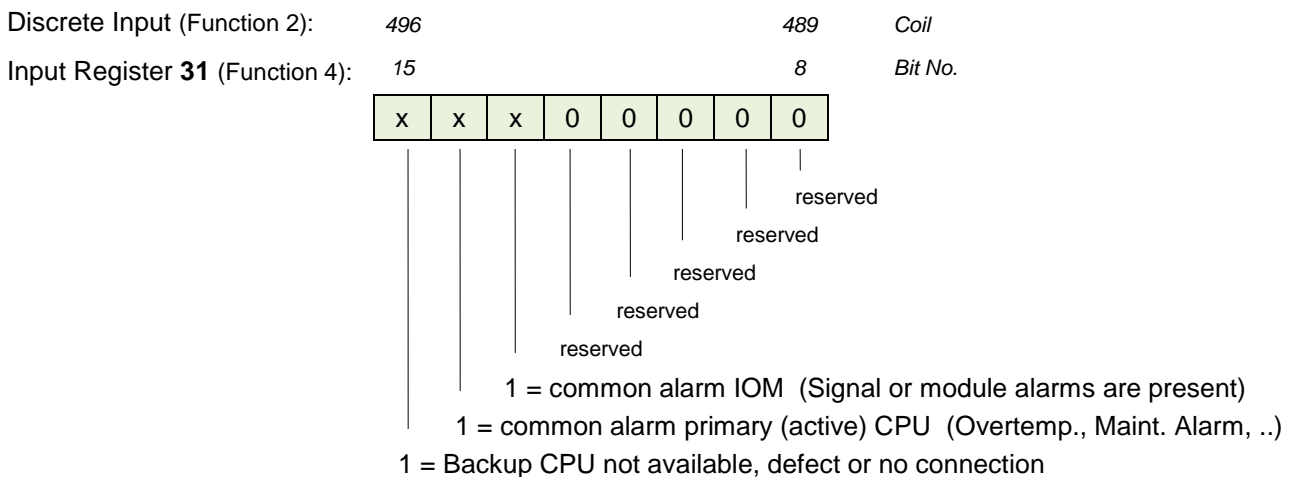

MODBUS interface description

3.3 Control register

One of two redundant CPUs in an IS1+ field station can be started by writing from the automation system to the control registers in the CPUs.

Data can be written to the control register using the MODBUS functions 06, 15 and 16.

Control register CPU:

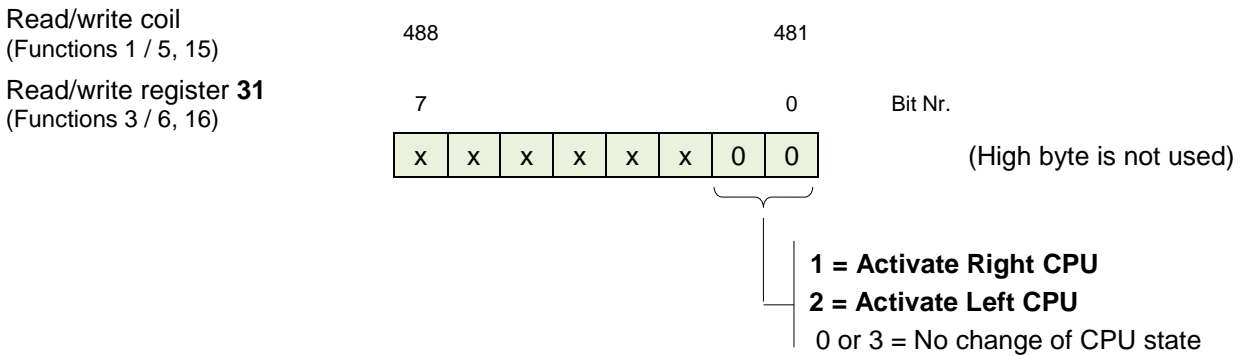

Left and Right CPM are exchanged using 9440 CPM !

The following parameters must be set if the control register is to be used:

Parameter name	Parameter value
IS1 CPU redundant	- Yes (note 'start condition')
CPU start condition	- Control register

The control register for starting one of two redundant CPUs must be written with identical content to both CPUs (CPU slot 0-0 and slot 0-1).

The CPU selected as primary (active) by the automation system must be continuously controlled with the respective control code (value 1 or 2). This facilitates automatic restart of the CPUs after malfunctions.

MODBUS interface description

3.5 Signal status

16 registers with signal status information can be read via the MODBUS functions 02 and 04 (register address 13 to 28).

One status bit is provided per signal with the following allocation:

- Status bit = 1 -> No signal malfunction or signal not available. No signal or module alarms present.
- Status bit = 0 -> Signal malfunction (short circuit, open circuit, module error....)

One Register can contain 16 signal status bits. Not used bits are set to '0'.
 Details of the alarms can be displayed via the IS1 DTMs.

Register allocation:

Input register (Function 4)	Discrete inputs (Function 2)	208	High Byte								201	200	Low Byte								193	Discrete inputs in reg 13
		15									8	7									0	Bit No.
13	193 - 208	S15	S8	S7	S0	Slot 1
14	209 - 224	S15	S8	S7	S0	Slot 2
15	225 - 240	S15	S8	S7	S0	Slot 3
16	241 - 256	S15	S8	S7	S0	Slot 4
17	257 - 272	S15	S8	S7	S0	Slot 5
18	273 - 288	S15	S8	S7	S0	Slot 6
19	289 - 304	S15	S8	S7	S0	Slot 7
20	305 - 320	S15	S8	S7	S0	Slot 8
21	321 - 336	S15	S8	S7	S0	Slot 9
22	337 - 352	S15	S8	S7	S0	Slot 10
23	353 - 368	S15	S8	S7	S0	Slot 11
24	369 - 384	S15	S8	S7	S0	Slot 12
25	385 - 400	S15	S8	S7	S0	Slot 13
26	401 - 416	S15	S8	S7	S0	Slot 14
27	417 - 432	S15	S8	S7	S0	Slot 15
28	433 - 448	S15	S8	S7	S0	Slot 16

MODBUS interface description

3.6 CPU Redundancy

In preparation ...

3.6.1 Non redundant Ethernet Network

Redundant IS1 CPUs can be connected to a not redundant Ethernet Network.

The IP-Addresses of both CPUs must be different.

The control of the redundancy must be handled in the DCS/PLC application.

Input Data can be read from both CPUs.

One of the two CPUs can be switched to the primary state via the control register or other write telegrams.

Valid output data must be written to the primary CPU. (see [Control register](#) and [CPU parameters](#)).

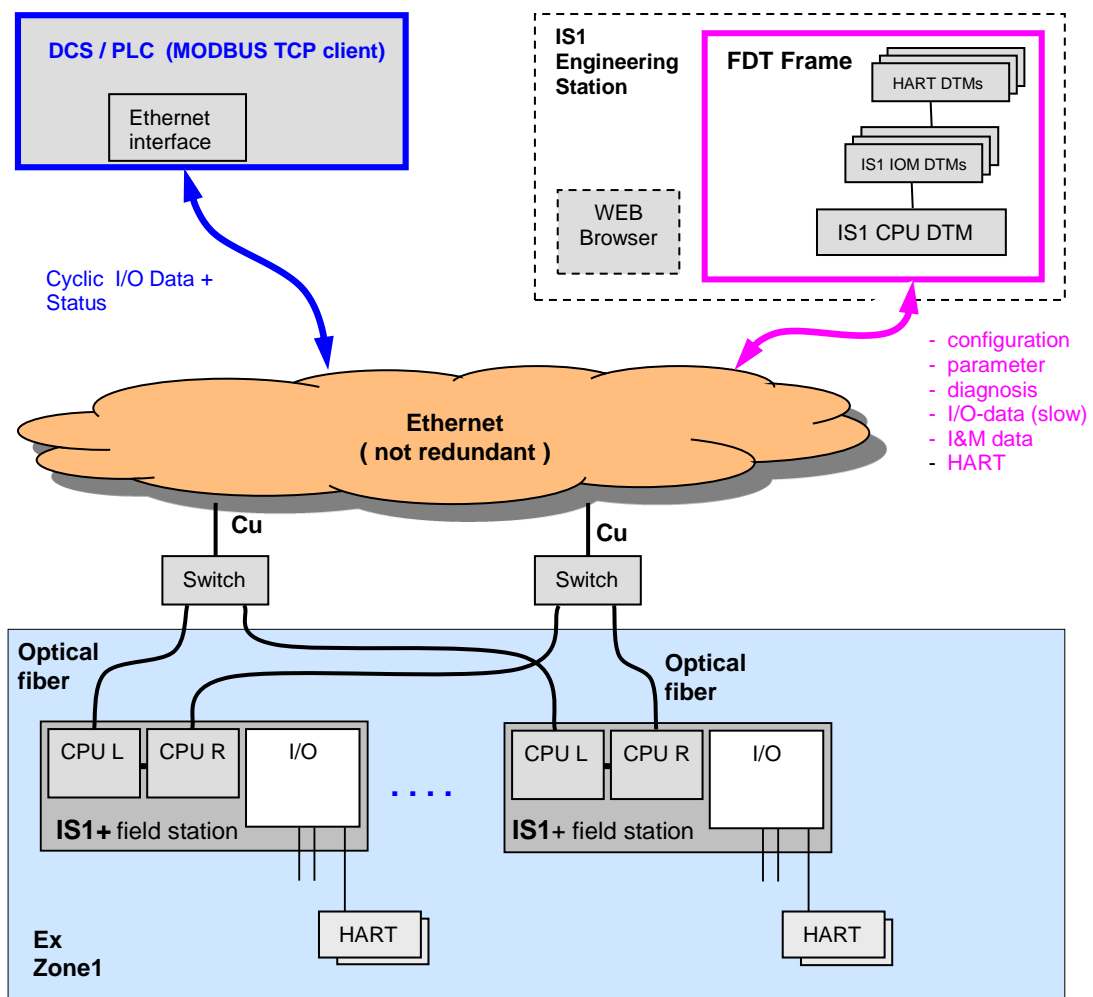

Connection of the IS1 Engineering Station:

The IS1 Engineering Station is connected to one of the two CPUs. Communication and diagnosis data of the other CPU can be accessed via a link between both CPUs.

MODBUS interface description

3.6.2 Redundant Ethernet Networks

If redundant Ethernet networks shall be used, the MODBUS TCP client must support redundant Ethernet interfaces.

Network structure:

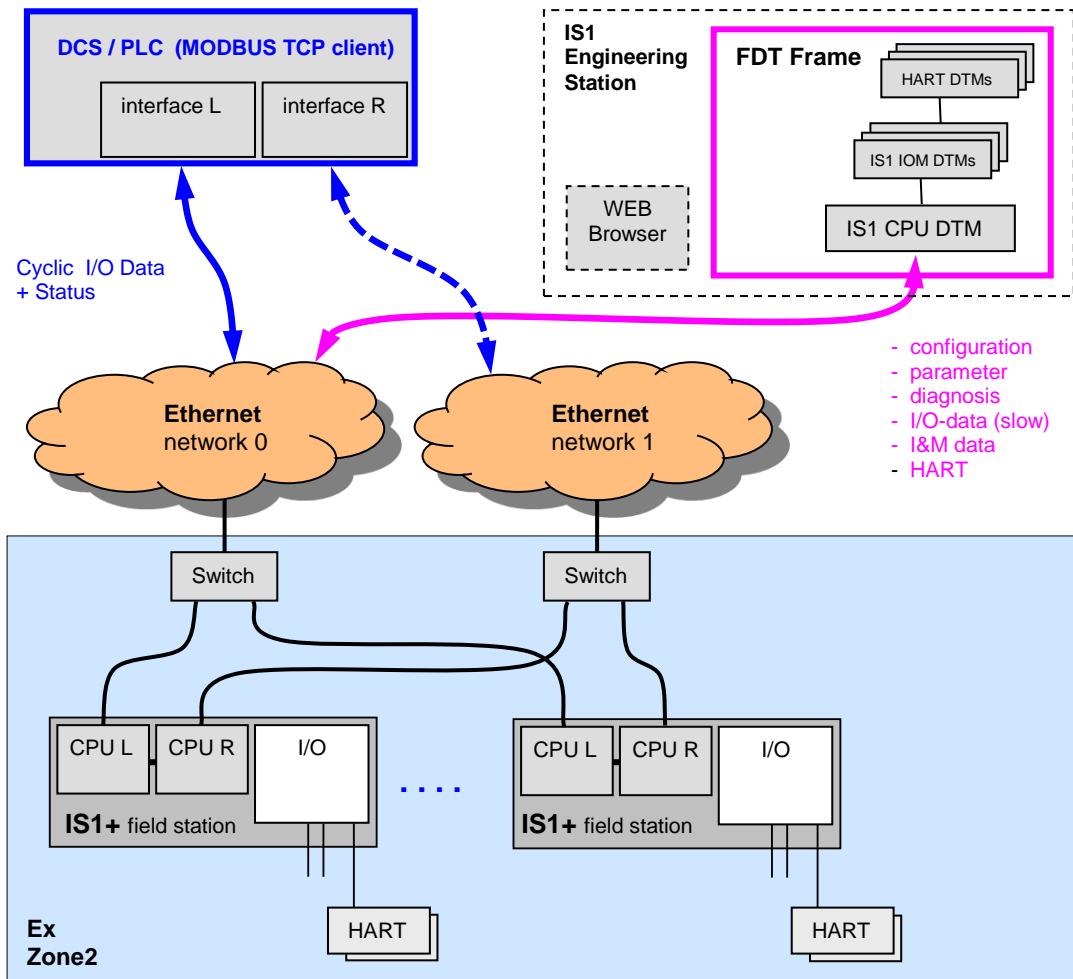

Connection of the IS1 Engineering Station:

The IS1 Engineering Station must be connected to one of the two networks and has only access to one of the two CPUs. Configuration-, parameter and diagnosis data of both CPUs as well as input- and output data are synchronized between both CPUs and are available for the DTM.

With the Event History Tool only data from the connected CPU can be accessed. If data from both CPUs are requested, the IS1 engineering PC must be connected alternately to each of the two networks to read the data.

A connection of both networks to one single network is not allowed!

MODBUS interface description

3.6.3 Ethernet IP- Addresses:

Depending on the requirements and the planning for the AS (MODBUS TCP clients) the IP addresses for the two redundant IS CPUs can be set the same (only on usage of redundant networks) or may be different (e.g. if both IS1 CPUs are connected to one network).

3.6.4 Parameterization:

When setting the parameters for the CPU, the parameter **'IS1 CPU redundant = Yes'** is to be selected in the IS1 DTMs for redundant operation.

In this case the parameter **'CPU start condition'** is effective.

If the parameter **'IS1 CPU redundant = No'** has been selected, one CPU will start for all write and read messages except MODBUS function 8 (loopback).

For correct redundancy switching in case of a malfunction on the active interface, the parameter **'Output modules timeout'** is to be set larger than the maximum switching time from the active IS1 CPU to the inactive IS1 CPU. This switching time is dependent on the behavior of the master (MODBUS TCP client) as well as on the Ethernet networks.

If the parameter **'Output modules timeout'** is set too low, output signals will briefly change to the safe setting during switching.

3.6.5 Selection of **'CPU start condition'**

The automation system (AS) selects one of the redundant interfaces for active (primary) and the other interface for backup operation. I/O Data is transferred only via the active interface. The selection of the active interface in the AS must be synchronized with the redundant IS1 CPUs.

The IS1 CPUs monitor different behavior of the two redundant interfaces of the AS as **'CPU start condition'**. After detection of a valid start condition on its interface each IS1 CPU changes to active operation.

This synchronization of the active IS1 CPU with the active interface of the AS must be ensured in all cases, even if e.g. only Input data are read.

The **'CPU start condition'** must only be fulfilled on the active interface of the MODBUS Masters.

Depending on the behavior of the MODBUS Master on the inactive interface and the data telegrams on the active interface the parameter **'CPU start condition'** has to be selected:

Data traffic on the primary (active) interface	Data traffic on the backup (inactive/standby) interface	Select parameter 'CPU start condition'
R/W	Loopback	Read telegram or Write telegram
R	Loopback	Read telegram
W	Loopback	Write telegram
R/W	R	Write telegram
W	R	Write telegram
R	R	Control register
R/W	R/W	Control register

R = **Read** (MODBUS functions 1, 2, 3 or 4) W = **Write** (MODBUS functions 6, 15 or 16)

Attention! If the CPU start condition is fulfilled on both CPUs at the same time, so both CPUs try to start. Both CPU must not be primary (active) at the same time. Via interacted interlocking at the MODBUS traffic of the already started CPU will be stopped for 5 seconds by a new started CPU. In such a case both CPU toggle after app. 5 Sec. between primary and backup state.

MODBUS interface description

Startup:

After power on the CPU started first becomes the primary (active). The other CPU becomes the backup (inactive).

All output modules remain in the safe setting.

All input modules supply cyclic input signals if valid configuration and parameter data are available.

After establishing of a cyclic MODBUS connection the CPU will change to the state 'data exchange' and monitors the cyclic data exchange of I/O data.

With a 'Write message' start condition a redundant CPU can also be started by a write message to an output area that is not configured.

3.6.6 Download of Configuration and Parameter data to redundant CPUs

Independent of the state of the two CPUs (primary / backup) the access from the IS1 Engineering Station to the connected CPU is possible.

The configuration and parameter data generated with the IS1 DTMs are transmitted via Ethernet with the function 'download' to both CPUs of a redundant IS1 fieldstation and are stored permanent in the socket of the CPU. If parameters are changed online with the IS1 DTMs, the changed data are also stored in both CPUs.

So that the replacement of a CPU does not result in the loss of the configuration, and in the event of a configuration error, a download is required; it will not be possible to rectify the error by replacing a CPU.

9441 CPU:

If only one CPU is in operation, newly loaded data can only be saved in the socket for this one CPU. If the second CPU is placed in operation later, without shutting down the first CPU after the download, the newly loaded data will be automatically copied to the socket for the new CPU.

If both CPUs are running after power on, the CPU that starts first uses the data available to it and starts to operate. The CPU starting later compares the data available to it with the data for the CPU already running. In the case of identical data, this CPU goes into operation and the backup state.

If there are discrepancies in the data, this CPU does not go into operation and signals a config/parameter error:

- Green LED flashes, red LED on
- LCD: Config/Param. Error
- DTM diagnostics overview indicates CPU state 4

In this case it is necessary to download from IS1 DTM again.

3.6.7 HART

The HART communication between the IS1 DTMs and HART field devices is possible via any of the two CPUs.

HART communication is possible immediately after power on without the operation of the MODBUS.

During a redundancy switch over between the two CPUs pending HART Telegrams may be interrupted.

3.6.8 Diagnosis using IS1 DTMs

Diagnostics data, input- and output signals as well as I&M data are available in both IS1 CPUs (primary and backup) and can be read by the IS1 DTMs from both CPUs.

It is only possible to read output data from the primary CPU.

In the case of the operation of an IS1+ field station without AS, it is possible to write output data from the IS1 DTMs to any of the two IS1 CPUs.

MODBUS interface description

3.6.9 WEB Server der IS1+ CPUs

Redundant IS1 + CPUs have separate Web servers.

Current configuration and diagnosis information can be displayed.

IP addresses can be displayed and changed. See [IP Address setting](#)

Access via Web Browser with: `http://xxx.xxx.xxx.xxx` (xxx.xxx.xxx.xxx = IP-SB Address IS1+ CPU)

3.6.10 Process data of CPUs during redundancy switch over

During standard operation of two redundant CPUs the in- and output signals in the memory of the backup CPU are cyclically updated by the primary CPU.

During a redundancy switch over all output registers in both CPUs are initialized with 0x8000 and output signals are frozen. If this output registers are not overwritten from the AS with valid output data the output signals will go to safe position after expiring of the timeout (parameter 'Timeout for output modules T_{Mod}').

MODBUS interface description

3.6.11 State of redundant 9441 CPUs

There is an LC display in a redundant socket of the 9441 CPU. Data from both 9441 CPUs can be displayed. The CPU to be displayed is to be selected on the menu. For detailed information on the LCD menu as well as the LED indications for the CPUs, see the operating instructions for the IS1 9441 CPU.

On the LC display the address of the **primary CPU** can be seen at the top left of the main menu:

CPU 0-0 Right CPU is primary
 CPU 0-1 Left CPU is primary

9442 CPU has no built-in display. Here the LEDs on the CPU, as well as the Web server can be used.

Examples for states displayed on the 9441 CPU:

CPU	primary	backup	Function -> Action
State	Data exchange with AS (2)	--	Primary CPU OK. No error. CPU cyclically updates I/O data using the I/O modules as well as via MODBUS TCP. The connection to the AS is monitored for all read and write messages as per parameter 'Watchdogtime AS interface'.
LCD	DataExch	--	
LED	RUN: on ERR: off	--	
State	--	Data exchange with AS (2)	Backup CPU communicating with cyclic messages (read or loopback) The connection to the AS is monitored: - For read messages as per parameter 'Watchdogtime AS interface'. In case of loss of connection -> data exchange with AS quit (5)
LCD	--	DataExch	
LED	--	RUN: on ERR: off	
State	Data exchange with AS quit (5)	--	No data exchange present! After power on, if valid configuration data are available or if 'Watchdogtime AS interface' has elapsed. Outputs are in the safe setting. -> Check: - LINK LED (OK if on or flashing) - Ethernet hardware connection (e.g. PING) - MODBUS TCP master (client) active? - Parameters set in AS and IS1+ field station: - IP address, subnet mask, gateway, port - Monitoring time too short?
LCD	QuitDataExch	--	
LED	RUN: flashing ERR: flashing inverted	--	
State	Data exchange with AS (2)	--	There are module errors! CPU is OK. (incorrect module, I/O module not responding ...). I/O alarms are displayed on the LEDs for the I/O module. -> Rectify module error!
LCD	DataExch	--	
LED	RUN: on ERR: flashing	--	
State	No data exchange (3)	No data exchange (3)	No configuration data or parameter data saved in the two CPUs. -> Perform download using the IS1 DTMs.
LCD	NoDataExch	NoDataExch	
LED	RUN: flashing ERR: off	RUN: flashing ERR: off	

MODBUS interface description

CPU	primary	Backup	Function -> Action
State	Configuration or parameter error (4)	--	Configuration or parameter error. No valid configuration data or parameter data saved in the CPU. -> Perform download using the IS1 DTMs.
LCD	Config error	--	
LED	RUN: flashing ERR: on	--	
State	--	Hardware Error	CPU hardware error. If a hardware error occurs in a CPU, the other CPU automatically becomes the primary CPU. This can indicate the state of the faulty backup CPU. -> Replace faulty CPU.
LCD	--	Hardware Error	
LED	--	RUN: off ERR: on	
State	Data exchange with AS (2)		The system parameters are set for redundancy. The backup CPU has failed or is not fitted. The primary CPU continues to work normally. -> Replace backup CPU or fit and place in operation
LCD	DataExch	"—"	
LED	RUN: on ERR: flashing		
State	Data exchange with AS (2)	--	The system parameters are not set for redundancy. However two CPUs have been fitted: The primary CPU continues to work normally. <ol style="list-style-type: none"> Continued operation without redundant CPUs: -> Remove backup CPU or: Change to operation with redundant CPUs: -> Configure system with redundant CPUs and download from DTM while both CPUs are fitted and in operation.
LCD	DataExch	noBackup	
LED	RUN: on ERR: flashing	--	

--	Any state
----	-----------

MODBUS interface description

3.6.12 Prepared / deactivated redundancy of 9441 CPUs

To prepare for future CPU redundancy or to deactivate redundancy, a redundant socket can be installed and only one 9441 CPU fitted in one of the two sockets.

CPU parameter setting: 'IS1 CPU redundant' = No

The mutual checking and provision of alarms in case of an error performed by redundantly operated 9441 CPUs is deactivated in this case.

Attention!

If two redundant CPUs are fitted and the parameter 'IS1 CPU redundant' = No is selected, then in the high byte of the status register the bit 'Backup CPU not available, defect or no connection' is set. The LEDs for the CPUs indicate the state DataExchange 'Module alarm'.

3.7 Setting parameters for the IS1+ field station

Configuration, parameter setting, diagnostics and HART communication for the IS1+ field stations is handled via the IS1 DTMs using FDT technology.

Configuration, parameterisation, diagnosis and hard communication of IS1+ field station is performed using MODBUS TCP over the IS1 DTMs with FDT technology or using MODBUS RTU via the tool IS Wizard.

Example:

The screenshot shows the 'Offline Parameter' window for an IS1 IOM DIM 9470. The 'Parameter IOM' section is active, showing the module type '9470/22-16-11' and operation mode '2 - DIM+Stat+CF'. Below this, a 'Parameter' table lists various settings like 'Diagnosis messages of module' and 'Operation mode input'. The 'Signals' table at the bottom lists 10 digital inputs (DI 0-9) with their respective terminals, signal names, and physical characteristics. The 'Register/Coil' column for each signal is circled in red.

No	Tag	Comment	Terminals	Signal ...	Phys. 0%	Phys. 100%	Unit	Register/Coil
0	DI 0		1(+), 2(-)	DI 0	0,0000	1,0000		32 / 497
1	DI 1		3(+), 4(-)	DI 1	0,0000	1,0000		32 / 498
2	DI 2		5(+), 6(-)	DI 2	0,0000	1,0000		32 / 499
3	DI 3		7(+), 8(-)	DI 3	0,0000	1,0000		32 / 500
4	DI 4		9(+), 10(-)	DI 4	0,0000	1,0000		32 / 501
5	DI 5		11(+), 12(-)	DI 5	0,0000	1,0000		32 / 502
6	DI 6		13(+), 14(-)	DI 6	0,0000	1,0000		32 / 503
7	DI 7		15(+), 16(-)	DI 7	0,0000	1,0000		32 / 504
8	DI 8		17(+), 18(-)	DI 8	0,0000	1,0000		32 / 505
9	DI 9		19(+), 20(-)	DI 9	0,0000	1,0000		32 / 506

For further information on the use of the IS1 DTMs see operating instructions 'DTM IS1 Mod'.

MODBUS interface description

3.7.1 CPU parameters

Parameter name	Parameter value (bold = default)	Available with	
		TCP	RTU
Baudrate MODBUS RTU Interface X1, RS485	- 9600 Baud - 19,2 kBaud - 38,4 kBaud	-	✓
Parity MODBUS RTU Interface X1	- Odd - Even	-	✓
Watchdogtime AS interface T _{WD} (x 100 ms) *1)	Unsigned8 (0 - 255) Default: 20 (0 = Watchdog Off)	✓	✓
Timeout for output modules T _{Mod} (x 100 ms) *4)	Unsigned8 (1 - 255) Default: 10	✓	✓
CPU redundant	- No (Parameter 'Start condition' not used.) - Yes (note 'start condition')	✓	✓
PM redundant	- No - Yes	CPU 9442 with PM 9445 only	
CPU start condition *2)	- MODBUS read message (01, 02, 03, 04) - MODBUS write message (06, 15, 16) - Control register	✓	✓
Alternative MODBUS port *3)	Unsigned16 (502 - 65535) Default: 502	9441 only	-
Float Format HART Var. (HV) *5)	- Swapped - Nonswapped	✓	✓

*1) **Attention:** A change to the parameter Watchdogtime AS interface in operation will result in a brief interruption and re-initialization of all existing MODBUS connections.

*2) This parameter is active only in case of redundant operation with 2 CPU's in one field station. In non-redundant operation (only one CPU in a field station) the CPU starts with every MODBUS read or write message except MODBUS function 8 (loopback).

*3) Communication via the MODBUS default port 502 is always possible. Additionally communication via the alternative MODBUS port is possible using 9441 CPUs.

*4) See Application Hint in chapter 3.10.2

*5) The IS1+ 9442 CPU supports both word swap format variants 'float' (default) and 'swapped float' for all HART data. 9440 and 9441 CPUs support format switching for HART Variable registers from address of 3001 only.

MODBUS interface description

3.7.2 I/O module parameters

3.7.2.1 AIM / AIMH 9461

Parameter	Default value	Value range / selection
Diagnostic messages of the module	On	Off On
Input Filter	Medium	Small Medium Big (50 Hz) Big (60 Hz)
Signal in case of error I 0	Status code	-10 % (4 mA only) 0 % 100 % Status code freeze (initial value 0%) freeze (initial value 100%)
Signal in case of error I 1	Status code	
Signal in case of error I 2	Status code	
Signal in case of error I 3	Status code	
Signal in case of error I 4	Status code	
Signal in case of error I 5	Status code	
Signal in case of error I 6	Status code	
Signal in case of error I 7	Status code	
Error detection I 0	On	Off On
Error detection I 1	On	
Error detection I 2	On	
Error detection I 3	On	
Error detection I 4	On	
Error detection I 5	On	
Error detection I 6	On	
Error detection I 7	On	
Input range I 0	4...20 mA	0...20 mA 4...20 mA
Input range I 1	4...20 mA	
Input range I 2	4...20 mA	
Input range I 3	4...20 mA	
Input range I 4	4...20 mA	
Input range I 5	4...20 mA	
Input range I 6	4...20 mA	
Input range I 7	4...20 mA	
Measurement range ac. NAMUR I 0	No	No Yes
Measurement range ac. NAMUR I 1	No	
Measurement range ac. NAMUR I 2	No	
Measurement range ac. NAMUR I 3	No	
Measurement range ac. NAMUR I 4	No	
Measurement range ac. NAMUR I 5	No	
Measurement range ac. NAMUR I 6	No	
Measurement range ac. NAMUR I 7	No	
Scan HART livelist	On	Off On
Input No. HART device for pos. 1	Not used	0...7 'Not used'
Input No. HART device for pos. 2	Not used	
Input No. HART device for pos. 3	Not used	
Input No. HART device for pos. 4	Not used	
Input No. HART device for pos. 5	Not used	
Input No. HART device for pos. 6	Not used	
Input No. HART device for pos. 7	Not used	
Input No. HART device for pos. 8	Not used	
No. HART variable for pos. 1	HART variable No. 2	HART variable No. 1 HART variable No. 2 HART variable No. 3 HART variable No. 4
No. HART variable for pos. 2	HART variable No. 2	
No. HART variable for pos. 3	HART variable No. 2	
No. HART variable for pos. 4	HART variable No. 2	
No. HART variable for pos. 5	HART variable No. 2	
No. HART variable for pos. 6	HART variable No. 2	
No. HART variable for pos. 7	HART variable No. 2	
No. HART variable for pos. 8	HART variable No. 2	

Default values in **'bold'**

Available only on HART modules (AIMH) !

MODBUS interface description

3.7.2.2 AUMH 9468

Parameter	Default value	Value range / selection
Diagnostic messages of the module	On	Off On
Input Filter	Medium	Small Medium Big (50 Hz) Big (60 Hz)
Signal in case of error I 0	AI Status Code / AO 0%	-10 % (4 mA only) 0 % 100 % AI Status Code / AO 0% freeze (initial value 0%) freeze (initial value 100%)
Signal in case of error I 1	AI Status Code / AO 0%	
Signal in case of error I 2	AI Status Code / AO 0%	
Signal in case of error I 3	AI Status Code / AO 0%	
Signal in case of error I 4	AI Status Code / AO 0%	
Signal in case of error I 5	AI Status Code / AO 0%	
Signal in case of error I 6	AI Status Code / AO 0%	
Signal in case of error I 7	AI Status Code / AO 0%	
Error detection I 0	On	Off On
Error detection I 1	On	
Error detection I 2	On	
Error detection I 3	On	
Error detection I 4	On	
Error detection I 5	On	
Error detection I 6	On	
Error detection I 7	On	
Input range I 0	4...20 mA	0...20 mA 4...20 mA
Input range I 1	4...20 mA	
Input range I 2	4...20 mA	
Input range I 3	4...20 mA	
Input range I 4	4...20 mA	
Input range I 5	4...20 mA	
Input range I 6	4...20 mA	
Input range I 7	4...20 mA	
Measurement range ac. NAMUR I 0	No	No *1) Yes
Measurement range ac. NAMUR I 1	No	
Measurement range ac. NAMUR I 2	No	
Measurement range ac. NAMUR I 3	No	
Measurement range ac. NAMUR I 4	No	
Measurement range ac. NAMUR I 5	No	
Measurement range ac. NAMUR I 6	No	
Measurement range ac. NAMUR I 7	No	

Default values in **'bold'**

- *1) The parameters 'Measurement range ac. NAMUR' are valid only for Input Signals !
The parameters are visible for all switchable AI/AO Signals but are without effect for the AO signals.

Signal type S0	Analog Input	Analog Input *2) Analog Output
Signal type S1	Analog Input	
Signal type S2	Analog Input	
Signal type S3	Analog Input	
Signal type S4	Analog Input	
Signal type S5	Analog Input	
Signal type S6	Analog Input	
Signal type S7	Analog Input	

- *2) The parameters 'Signal type Sx' are available only for AI/AO switchable channels in the operating modes 9468/3x-08-xx 8AIH/8AOH (+4HV / +8HV)

MODBUS interface description

Scan HART livelist	On	Off On
Input No. HART device for pos. 1	Not used	0...7 Not used
Input No. HART device for pos. 2	Not used	
Input No. HART device for pos. 3	Not used	
Input No. HART device for pos. 4	Not used	
Input No. HART device for pos. 5	Not used	
Input No. HART device for pos. 6	Not used	
Input No. HART device for pos. 7	Not used	
Input No. HART device for pos. 8	Not used	
No. HART variable for pos. 1	HART variable No. 2	HART variable No. 1 HART variable No. 2 HART variable No. 3 HART variable No. 4
No. HART variable for pos. 2	HART variable No. 2	
No. HART variable for pos. 3	HART variable No. 2	
No. HART variable for pos. 4	HART variable No. 2	
No. HART variable for pos. 5	HART variable No. 2	
No. HART variable for pos. 6	HART variable No. 2	
No. HART variable for pos. 7	HART variable No. 2	
No. HART variable for pos. 8	HART variable No. 2	

Available only on HART modules (AIMH) !

MODBUS interface description

3.7.2.3 UMH 9469 Exn

Parameter	Default value	Value range/selection
Diagnostic messages of the module	On	Off On
Signal Filter	Medium	Small Medium Big (50 Hz) Big (60 Hz)
DI Pulse extension 1,2 s	Off	Off On
Measurement range ac. NAMUR	No	No *1) Yes
Signal range	4-20 mA	0-20 mA 4-20 mA
Signal in case of error I 0	AI Status Code / AO 0% / 0	-10 % (4 mA only) / 0 0 % / 0 100 % / 1 AI Status Code / AO 110 % / 1 AI Status Code / AO 0% / 0 freeze (initial value 0% / 0) freeze (initial value 100% / 1)
Signal in case of error I 1	AI Status Code / AO 0% / 0	
Signal in case of error I 2	AI Status Code / AO 0% / 0	
Signal in case of error I 3	AI Status Code / AO 0% / 0	
Signal in case of error I 4	AI Status Code / AO 0% / 0	
Signal in case of error I 5	AI Status Code / AO 0% / 0	
Signal in case of error I 6	AI Status Code / AO 0% / 0	
Signal in case of error I 7	AI Status Code / AO 0% / 0	
Error detection I 0	On	Off On
Error detection I 1	On	
Error detection I 2	On	
Error detection I 3	On	
Error detection I 4	On	
Error detection I 5	On	
Error detection I 6	On	
Error detection I 7	On	
Connection S 0	2 wire analog	2 wire analog
Connection S 1	2 wire analog	
Connection S 2	2 wire analog	
Connection S 3	2 wire analog	
Connection S 4	2 wire analog	2 wire analog 3/4 wire analog (Input only) digital
Connection S 5	2 wire analog	
Connection S 6	2 wire analog	
Connection S 7	2 wire analog	
Signal type S0	Input	Input *2) Output
Signal type S1		
Signal type S2		
Signal type S3		
Signal type S4		
Signal type S5		
Signal type S6		
Signal type S7		

Scan HART Livelist	On	Off On
Input No. HART device for pos. 1	Not used	0...7 Not used
...	...	
Input No. HART device for pos. 8	Not used	HART variable No. 1 HART variable No. 2 HART variable No. 3 HART variable No. 4
No. HART variable for pos. 1	HART variable No. 2	
...	...	
No. HART variable for pos. 8	HART variable No. 2	

Available if HART variables (HV) are configured only.

MODBUS interface description

Parameter dependency / impact

Signal	Parameter							
	Signal type	connection	Signal range	Error detection	Measurement range ac. NAMUR	Signal in case of error	Input Filter	
2 wire 0/4-20 mA Input	Input	2 wire analog	0-20 / 4-20	On / Off	Yes / No	-10 % (nur 4 mA) / 0 0 % / 0 100 % / 1 AI Status Code / AO110 % / 1 AI Status Code / AO 0% / 0 freeze (initial value 0% / 0) freeze (initial value 100% / 1)	Small Medium Big (50 Hz) Big (60 Hz)	
2/3 wire Initiator Input	Input	2/3 wire digital	-		-			
3/4 wire 0/4-20 mA Input	Input	<i>3/4 wire analog (Input only)</i>	0-20 / 4-20		Yes / No			
2 wire 0/4-20 mA Output	Output	2 wire analog	0-20 / 4-20		-			-
Digital Output	Output	2/3 wire digital	-		-			-

*1) The parameter 'Measurement range ac. NAMUR' are effective for analog input signals only!

*2) The Parameter '**Signal type**' is available for switchable signals in the operating modes with 8I + 8O only.

MODBUS interface description

3.7.2.4 TIMR 9480

Parameter	Default value	Value range / selection
Diagnostic messages of the module	On	Off On
Input Filter	50 Hz	50 Hz 60 Hz Off (not recommended)
Operation mode	8 inputs	8 inputs 2 inputs
Signal in case of error I 0	Status code	Status code freeze (initialization value 0%)
Signal in case of error I 1	Status code	
Signal in case of error I 2	Status code	
Signal in case of error I 3	Status code	
Signal in case of error I 4	Status code	
Signal in case of error I 5	Status code	
Signal in case of error I 6	Status code	
Signal in case of error I 7	Status code	
Error detection I 0	On	Off On
Error detection I 1	On	
Error detection I 2	On	
Error detection I 3	On	
Error detection I 4	On	
Error detection I 5	On	
Error detection I 6	On	
Error detection I 7	On	
Type I 0	Pt 100	Pt100 Pt500 Pt1000 Ni100 Ni500 Ni1000 Resistance 10k Resistance 5k Resistance 2k5 Resistance 500R Pt100 GOST M50 GOST M100 GOST Cu53 GOST Pt46 GOST Pt50 GOST
Type I 1	Pt 100	
Type I 2	Pt 100	
Type I 3	Pt 100	
Type I 4	Pt 100	
Type I 5	Pt 100	
Type I 6	Pt 100	
Type I 7	Pt 100	
Connection I 0	4 wire	2 wire 3 wire 4 wire
Connection I 1	4 wire	
Connection I 2	4 wire	
Connection I 3	4 wire	
Connection I 4	4 wire	
Connection I 5	4 wire	
Connection I 6	4 wire	
Connection I 7	4 wire	

MODBUS interface description

3.7.2.5 TIM mV 9481

Parameter	Default value	Value range / selection
Diagnostic messages of the module	On	Off On
Input Filter	50 Hz	50 Hz 60 Hz
Signal in case of error I 0	Status code	Status code freeze (initialization value 0%)
Signal in case of error I 1	Status code	
Signal in case of error I 2	Status code	
Signal in case of error I 3	Status code	
Signal in case of error I 4	Status code	
Signal in case of error I 5	Status code	
Signal in case of error I 6	Status code	
Signal in case of error I 7	Status code	
Error detection I 0	On	Off On
Error detection I 1	On	
Error detection I 2	On	
Error detection I 3	On	
Error detection I 4	On	
Error detection I 5	On	
Error detection I 6	On	
Error detection I 7	On	
Type I 0	THC Type K	0...100 mV THC Type B THC Type E THC Type J THC Type K THC Type N THC Type R THC Type S THC Type T THC Type L THC Type U THC Type XK (L)
Type I 1	THC Type K	
Type I 2	THC Type K	
Type I 3	THC Type K	
Type I 4	THC Type K	
Type I 5	THC Type K	
Type I 6	THC Type K	
Type I 7	THC Type K	
Input signal I 0	Balanced	Balanced Unbalanced
Input signal I 1	Balanced	
Input signal I 2	Balanced	
Input signal I 3	Balanced	
Input signal I 4	Balanced	
Input signal I 5	Balanced	
Input signal I 6	Balanced	
Input signal I 7	Balanced	

MODBUS interface description

3.7.2.6 TIM 9482

Parameter	Default value	Value range / selection
Diagnostic messages of the module	On	Off On
Module operation mode	8 channel precise	8 channel precise 4 channel fast
Signal in case of error I 0	Status code	Status code freeze (initialization value 0%)
Signal in case of error I 1	Status code	
...	...	
Signal in case of error I 6	Status code	
Signal in case of error I 7	Status code	
Error detection I 0	On	Off On
Error detection I 1	On	
...	...	
Error detection I 6	On	
Error detection I 7	On	
Selection TC cold junction	Internal	Internal External 3 wire
Type TC ext. cold junction I6-I7	PT100	PT100 PT1000 PT100 GOST
Type I 0	PT100	Pt100 Pt500 Pt1000 Ni100 Ni500 Ni1000 Resistance (Pot) 10k Resistance (Pot) 5k Resistance (Pot) 2k5 Resistance (Pot) 500R Pt100 GOST M50 GOST M100 GOST Cu53 GOST Pt46 GOST Pt50 GOST 0...100 mV THC Type B THC Type E THC Type J THC Type K THC Type N THC Type R THC Type S THC Type T THC Type L THC Type U THC Type XK (L)
Type I 1	PT100	
Type I 2	PT100	
Type I 3	PT100	
Type I 4	PT100	
Type I 5	PT100	
Type I 6	PT100	
Type I 7	PT100	
Connection (R) I 0 *1)	4 wire measure (R in Ohm)	2 wire measure (Pot in Ohm) 3 wire measure (Pot in %) 4 wire measure (Pot in Ohm) 4 wire measure (Pot in %)
Connection (R) I 1	4 wire measure (R in Ohm)	
...	...	
Connection (R) I 6	4 wire measure (R in Ohm)	
Connection (R) I 7	4 wire measure (R in Ohm)	

*1) Parameter 'Connection' using THC not functioning. 2 wire measurement is used for TCH

MODBUS interface description

3.7.2.7 DIM (9470/3x in compatible mode)

Parameter	Default value	Value range / selection
Diagnostic messages of the module	On	Off On
Signal in case of error I 0	0	0 1 freeze (initial value 0) freeze (initial value 1)
Signal in case of error I 1		
....		
Signal in case of error I 14		
Signal in case of error I 15		
Error detection I 0	On	Off On
Error detection I 1		
....		
Error detection I 14		
Error detection I 15		
Invert I 0	No	No Yes
Invert I 1		
....		
Invert I 14		
Invert I 15		
Pulse extension I 0	0 Sec.	0 s 0.6 s 1.2 s 2.4 s
Pulse extension I 1		
....		
Pulse extension I 14		
Pulse extension I 15		
Operation mode I 14	Freq. 0-1 kHz / DI	Counter Freq. 0-1 kHz / DI Freq. 0-20 kHz gate 50 ms / DI Freq. 0-20 kHz gate 200 ms / DI Freq. 0-20 kHz gate 1 s / DI
Counter event I 14	Positive edge	Positive edge Negative edge
Operation mode I 15	Freq. 0-1 kHz / DI	s. a.
Counter event I 15	Positive edge	s. a.

Parameter not available for DIM 24 V ! (9471/...)

Parameters available only in the case of operating mode DIM16 + CF!

MODBUS interface description

3.7.2.8 DIOM 9470/3x (IS1+)

Parameter	Default value	Value range / selection	
Diagnostic messages of the module	On	Off On	
Signal in case of error S 0	0	0 1 freeze (initial value 0) freeze (initial value 1)	
Signal in case of error S 1			
Signal in case of error S 2			
....			
Signal in case of error S 14			
Signal in case of error S 15			
Error detection S 0	On	Off On	
Error detection S 1			
Error detection S 2			
....			
Error detection S 14			
Error detection S 15			
Invert DI S0, S1	No	No Yes (affects DI signals only)	
Invert DI S2, S3			
Invert DI S4, S5			
Invert DI S6, S7			
Invert DI S8, S9			
Invert DI S10, S11			
Invert DI S12, S13			
Invert DI S14, S15			
Pulse extension / Filter S0, S1	0 Sec.	0 s / Off 0,6 s / Small 1,2 s / Medium 2,4 s / Large	
Pulse extension / Filter S2, S3			
Pulse extension / Filter S4, S5			
Pulse extension / Filter S6, S7			
Pulse extension / Filter S8, S9			
Pulse extension / Filter S10, S11			
Pulse extension / Filter S12, S13			
Pulse extension / Filter S14, S15			
Signal type S0, S1	Input	9470/3x	9471/35, 9472/35 NAMUR Ini/ contact 3-wire Initiator PNP Output
Signal type S2, S3			
Signal type S4, S5			
Signal type S6, S7			
Signal type S8, S9			
Signal type S10, S11			
Signal type S12, S13			
Signal type S14, S15			
Operation mode S8, S9	Freq. 1Hz - 3kHz (0,05Hz/Bit)	0 = Counter 16 Bit 1 = Freq. 0,1 - 600 Hz (0,01Hz/Bit) 2 = Freq. 1 Hz - 3 kHz (0,05Hz/Bit) 3 = Freq. 1 Hz - 20 kHz (0,5Hz/Bit) 4 = Up/Down Counter 16 Bit 5 = Up/Down Counter 32 Bit 6 = Freq. 1 Hz - 20 kHz with direction	
Operation mode S10, S11			
Operation mode S12, S13			
Operation mode S14, S15			
Counter event S8, S9	Positive edge	Positive edge Negative edge	
Counter event S10, S11			
Counter event S12, S13			
Counter event S14, S15			

Parameters available only in the case of operating mode with DI/DO

Parameters available only in the case of operating mode with CF (counter/frequency)

MODBUS interface description

3.7.2.9 AOM / AOMH 9466

Parameter	Default value	Value range / selection
Diagnostic messages of the module	On	Off On
Signal in case of error O 0	0 %	-10 % (4 mA only) 0 % 100 % 110 % freeze
Signal in case of error O 1	0 %	
Signal in case of error O 2	0 %	
Signal in case of error O 3	0 %	
Signal in case of error O 4	0 %	
Signal in case of error O 5	0 %	
Signal in case of error O 6	0 %	
Signal in case of error O 7	0 %	
Error detection O 0	On	Off On
Error detection O 1	On	
Error detection O 2	On	
Error detection O 3	On	
Error detection O 4	On	
Error detection O 5	On	
Error detection O 6	On	
Error detection O 7	On	
Output range O 0	4...20 mA	0...20 mA 4...20 mA
Output range O 1	4...20 mA	
Output range O 2	4...20 mA	
Output range O 3	4...20 mA	
Output range O 4	4...20 mA	
Output range O 5	4...20 mA	
Output range O 6	4...20 mA	
Output range O 7	4...20 mA	
Scan HART livelist	On	Off On
Output No. HART device for pos. 1	Not used	0...7 Not used
Output No. HART device for pos. 2	Not used	
Output No. HART device for pos. 3	Not used	
Output No. HART device for pos. 4	Not used	
Output No. HART device for pos. 5	Not used	
Output No. HART device for pos. 6	Not used	
Output No. HART device for pos. 7	Not used	
Output No. HART device for pos. 8	Not used	
No. HART variable for pos. 1	HART variable No. 2	HART variable No. 1 HART variable No. 2 HART variable No. 3 HART variable No. 4
No. HART variable for pos. 2	HART variable No. 2	
No. HART variable for pos. 3	HART variable No. 2	
No. HART variable for pos. 4	HART variable No. 2	
No. HART variable for pos. 5	HART variable No. 2	
No. HART variable for pos. 6	HART variable No. 2	
No. HART variable for pos. 7	HART variable No. 2	
No. HART variable for pos. 8	HART variable No. 2	

Available only on HART modules (AOMH) !

MODBUS interface description

3.7.2.10 DOM

Parameter	Default value	Value range / selection	Parameter available		
			DOM	DOMR	DOMV
Diagnostic messages of the module	On	Off On	✓	✓	✓
Signal in case of error O 0	0	0 1 Freeze	✓	✓	✓
Signal in case of error O 1	0				
Signal in case of error O 2	0				
Signal in case of error O 3	0				
Signal in case of error O 4	0				
Signal in case of error O 5	0				
Signal in case of error O 6	0				
Signal in case of error O 7	0				
Error detection O 0	On	Off On without test current On	✓	-	-
Error detection O 1	On				
Error detection O 2	On				
Error detection O 3	On				
Error detection O 4	On				
Error detection O 5	On				
Error detection O 6	On				
Error detection O 7	On				
Output 0 and 1 parallel	Outputs separate	Outputs separate Outputs parallel	✓	✓	-
Output 2 and 3 parallel	Outputs separate				
Output 4 and 5 parallel	Outputs separate				
Output 6 and 7 parallel	Outputs separate				

MODBUS interface description

3.8 Data word structure of the I/O modules

3.8.1 Analogue modules

Analogue signals are exchanged between the IS1+ field station and an automation system in 16-bit two's complement format (signed integer, high byte first if using Register functions). Converting to and from floating point variables (physical values) must be performed in the automation system if required.

3.8.1.1 AIM, AIMH (9460/..., 9461/..., 9468/..., 9469/..)

Measuring range 0 – 20 mA	Units		%	Parameter: Measurement range limits according NAMUR	Range	Diagnosis messages
	Decimal	Hex				
>23.518 mA >21 mA	*1)	*1)		No Yes		Short circuit
23.518 mA 21 mA	32511 29030	7EFF 7166	117.6% 105 %	No Yes	Over range	-
20 mA 10 mA 0 mA	27648 13824 0	6C00 3600 0	100% 50% 0%		Nominal range	-
< 0 mA	0	0	0%			

Measuring range 4 – 20 mA	Units		%	Parameter: Measurement range limits according NAMUR	Range	Diagnosis messages
	Decimal	Hex				
>22.814 mA >21 mA	*1)	*1)		No Yes		Short circuit
22.814 mA 21 mA	32511 29376	7EFF 72C0	117.6% 106,25 %	No Yes	Over range	-
20 mA 12 mA 4 mA	27648 13824 0	6C00 3600 0	100% 50% 0%		Nominal range	-
3.999 mA 3,6 mA 2.4 mA	-1 -691 -2765	FFFF FD4D F533	-2,5% -10%	Yes No	Under range	-
< 3,6 mA < 2.4 mA	*1)	*1)		Yes No		Line break

*1) Transmitted value depends on parameterized behavior if an error occurs:

Parameterized behavior if an error occurs	Type of error	Value transmitted if an error occurs	
freeze	All IOM errors	Last valid value	
-10%	All IOM errors	-2765	0xF533
0%	All IOM errors	0	0x0000
100%	All IOM errors	27648	0x6C00
Status code General rule to generate status information in AS for all AI signals: Signal is disturbed if Value >= 32512 or Value <= -32512 see Behavior of the input signals in case of errors	Short circuit	32767	0x7FFF
	Open circuit	-32762	0x8006
	2 wire calibration failed	-32749	0x8013
	Parametrization error	-32748	0x8014
	Plant Stop	-32747	0x8015
	IOM does not respond	-32736	0x8020
	Config. unequal from module	-32735	0x8021
	Data not available	-32734	0x8022
IOM hardware error	-32733	0x8023	

MODBUS interface description

Measurement range limits according NAMUR:

The limits of the measurement range to the short circuit and open circuit area can be modified by the parameter 'Measurement range limits according NAMUR' according the above table.

For 9468 AUMH the parameters 'Measurement range ac. NAMUR' are valid for Input Signals only!
The parameters are visible for all switchable AI/AO Signals but are without effect for the AO signals.

Data word structure cyclic analog data AIM 9460/..., AIMH 9461/... without Signal Status

Data	Register	Operation mode			Var. Type	Signals
		8AI	8AI+4HV	8AI+8HV		
Input	1		AI0		INT16	Analog Input signals AI0 – AI7
	2		AI1			
	3		AI2			
	4		AI3			
	5		AI4			
	6		AI5			
	7		AI6			
	8		AI7			
	9 - 10			HV-P1	Float 32	HART Variables transmitted on positions P1 - P8
	11 - 12			HV-P2		
	13 - 14			HV-P3		
	15 - 16			HV-P4		
	17 - 18			HV-P5		
	19 - 20			HV-P6		
	21 - 22			HV-P7		
23 - 24			HV-P8			

MODBUS interface description

Data word structure cyclic data AUMH 9468/... and UMH 9469/.. with Signal Status

9468:		8AI	8AO	6AI+2AO	8AI/8AO	8AI+4HV	8AO+4HV	8AI/8AO+4HV	8AI+8HV	8AO+8HV	8AI/8AO+8HV
9469:		8I	8O	6I+2O	8I/8O	8I+4HV	8O+4HV	8I/8O+4HV	8I+8HV	8O+8HV	8I/8O+8HV
Data	Reg.	Operation mode									
Input	1	10	S0 - S7 0	10	10	10	S0 - S7 0	10	10	S0 - S7 0	10
	2	11	-	11	11	11	HV-P1	11	11	HV-P1	11
	3	12		12	12	12		HV-P2	12		12
	4	13		13	13	13	HV-P3		13	13	HV-P3
	5	14		14	14	14		HV-P4	14	14	
	6	15		15	15	15	HV-P5		15	15	HV-P5
	7	16		S0-S7 0	16	16		HV-P6	16	16	
	8	17		17	17	17	HV-P7		17	17	HV-P7
	9	S0 - S7 0		S0 - S7 0	S0 - S7 0	S0 - S7 0		HV-P8	S0 - S7 0	S0 - S7 0	
	10 - 11	-		-	-	-	-		HV-P1	HV-P1	HV-P1
	12 - 13							HV-P2	HV-P2	HV-P2	HV-P2
	14 - 15							HV-P3	HV-P3	HV-P3	HV-P3
	16 - 17							HV-P4	HV-P4	HV-P4	HV-P4
	18 - 19							HV-P5	HV-P5	HV-P5	HV-P5
	20 - 21							HV-P6	HV-P6	HV-P6	HV-P6
	22 - 23							HV-P7	HV-P7	HV-P7	HV-P7
	24 - 25							HV-P8	HV-P8	HV-P8	HV-P8
Output	1	-		-	O0	O6	O0	-	O0	O0	-
	2		O1		O7	O1	O1		O1		
	3		O2		O2	O2	O2		O2		
	4		O3		O3	O3	O3		O3		
	5		O4		O4	O4	O4		O4		
	6		O5		O5	O5	O5		O5		
	7		O6		O6	O6	O6		O6		
	8		O7		O7	O7	O7		O7		

Readback: In all 8AI/8AO operation modes using channel parameterization as AO the written output value can be read via the associated AI signal (Readback). Using channel parameterization as AI, written dedicated AO signals have no effect.

Variable	Type	Hint		
AI/AO I0-I7/O0-O7	INT16	scaling see above		
DI/DO I0-I7/O0-O7 (9469/..)	INT16	DI: 0 = Off, 1 = On DO: <=0 = Off, >0 = On		
Status S0 – S7	UINT16	Status Bit	Signal	Status
		0	disturbed	
		1	OK	
HART variables HV	Float 32	HART Variables (HV-Px) are transmitted on positions P1 to P8		

MODBUS interface description

3.8.1.2 TIM (9480/.. , 9481/.. , 9482/..)

Temperature measurement (1 Digit = 0,1 °C)

Temperature	Units		Range	Diagnosis messages
	Decimal	hexadecimal		
	*1)	*1)		Line break / Upper limit exceeded
*2) 1000 °C	*2) 10000	*2) 2710	Temperature measurement range	
1 °C	10	000A		
0 °C	0	0		
-0,1 °C	-1	FFFF		
-100 °C	-1000	FC18		
*2)	*2)	*2)		Lower limit exceeded / short circuit
	*1)	*1)		

*2) The limits of the measurement range are pending on the parameterized input type (see Operating instructions IS1)

2 wire and 4 wire Resistance Measurement Pot in Ohm 500 R ...10K (module 9480 /.. , 9482/..)

Range				Units		%	Range	Diagnosis messages
500 R	2 K 5	5 K	10 K	decimal	hexadecimal			
>588 R	>2,94 K	> 5,88K	>11,76 K	*1)	*1)			Line break
588 R	2,94 K	5,88 K	11,76 K	32511	7EFF	117,6%	Over range	-
500 R	2 K 5	5 K	10 K	27648	6C00	100%	Nominal range	-
250 R	1K250	2K5	5 K	13824	3600	50%		
0 K	0 K	0 K	0 K	0	0	0%		

3 wire and 4 wire Resistance Position Measurement Pot in % 500 R...10K (module 9480/.. , 9482/..)

Range				Units		%	Range	Diagnosis messages
500R	2K5	5 K	10 K	decimal	hexadecimal			
>588 R	>2,94 K	>5,88 K	>11,76K	*1)	*1)			Line break
position 100 %				27648	6C00	100%	Nominal range	-
position 50 %				13824	3600	50%		
position 0 %				0	0	0%		
< 50 R	< 250 R	< 500 R	< 1 K	*1)	*1)			short circuit

0,02 R	0,1 R	0,2 R	0,4 R	Resolution per Digit
--------	-------	-------	-------	----------------------

Hint: 9480 supports no 4 wire Resistance Position Measurement in %.

MODBUS interface description

0 ... 100 mV measurement (9481/.., 9482/..)

Range 0 ... 100 mV	Units		%	Range	Diagnosis messages
	decimal	hexadecimal			
>117,6 mV	*1)	*1)			Upper limit exceeded
117,6 mV	32511	7EFF	117,6 %	Over range	-
100 mV	27648	6C00	100 %	Nominal range	-
50 mV	13824	3600	50 %		
0 mV	0	0	0 %		
-0,0036 mV	-1	FFFF		Under range	-
-10 mV	-2765	F533	-10 %	(9481/..)	
-117,6 mV	-32511	8101	-117,6%	(9482/..)	
<	*1)	*1)			Lower limit exceeded

Short circuit alarm cannot be detected at Resistance and Voltage measurement !

***1) Transmitted value depends on parameterized behavior if an error occurs:**

Parameterized behavior if an error occurs	Type of error	Value transmitted if an error occurs	
freeze	All IOM errors	Last valid value	
Status code General rule to generate status information in AS for all AI signals: Signal is disturbed if value ≥ 32512 or value ≤ -32512 see Behavior of the input signals in case of errors	Short circuit *2)	+ / - 32767	7FFF / 8001
	Open circuit *2)	+ / - 32762	7FFA / 8006
	Upper limit exceeded	32761	7FF9
	Lower limit exceeded	-32760	8008
	Cold Junction error	-32752	8010
	2 wire calibration failed	-32749	8013
	IOM does not respond	-32736	8020
	Config. unequal from module	-32735	8021
	Data not available	-32734	8022
	IOM hardware error	-32733	8023

***2)** depending of the direction of signal change at the respective error type a positive or negative Status code is used:

error type	TIM R 9480/..	TIM mV 9481/..
	TIM 9482/.. (R measurement)	TIM 9482/.. (mV measurement)
short circuit	-32767 (8001)	not detectable
open circuit	+32762 (7FFA)	-32762 (8006)

An automatic 2 wire calibration function of the TIM 9482 /... can be used optionally, see operating instructions 9482.

MODBUS interface description

Data word structure cyclic data TIM 9482/.. with Signal Status

Type	Byte	Data / channel	Var. Type	Usage
Input	1	I0	INT 16	Analog input data
	2			
	3	I1		
	4			
	5	I2		
	6			
	7	I3		
	8			
	9	I4		
	10			
	11	I5		
	12			
	13	I6		
	14			
	15	I7		
	16			
	17	S0 - S7	INT 16	Signal Stati 0-7 0=Signal disturbed, 1=Signal OK
18	0			

MODBUS interface description

3.8.1.3 AOM 0 – 20 mA (9465/... , 9466/..., 9468/.., 9469/..)

Measuring range 0 – 20 mA	Units		%	Range
	Decimal	Hexadecimal		
*1)	>30137	>75B9		
21,8 mA	30137	75B9	109%	Over range
.	.	.		
20 mA	27648	6C00	100%	Nominal range
.	.	.		
10 mA	13824	3600	50%	
.	.	.		
0 mA	0	0	0%	
0 mA	< 0	< 0		

AOM 4 – 20 mA

Measuring range 4 – 20 mA	Units		%	Range
	Decimal	Hexadecimal		
*1)	>30759	>7827		
21,8 mA	30759	7827	111,25%	Over range
.	.	.		
20 mA	27648	6C00	100%	Nominal range
.	.	.		
12 mA	13824	3600	50%	
.	.	.		
4 mA	0	0	0%	
3,999 mA	-1	FFFF		Under range
0 mA	-6912	E500	-25%	
0 mA	< -6912	< E500		

*1): The AOM attempts to increase the current further according to the control value. However, depending on the burden effective resistance, the maximum output voltage of the AOM may be reached whereby the current can no longer be increased.

Safety position after Power On:

After Power On of the CPM the data area of the outputs is initialized with the value -32768 (0x8000) as signal for the safety position.

The outputs remain in the save position as long as the allocated register is overwritten with a valid output value (<> -32768 (0x8000)) from AS or from IS Wizard.

MODBUS interface description

Data word structure cyclic analog data AOM 9460/..., AOMH 9461/...

	Register	Operation mode			Var. Type	Signals	
		8AO	8AO+4HV	8AO+8HV			
Input	1 – 2	-	HV-P1		Float 32	HART Variables transmitted on positions P1 - P8	
	3 – 4		HV-P2				
	5 – 6		HV-P3				
	7 – 8		HV-P4				
	9 – 10		-	HV-P5			
	11 – 12			HV-P6			
	13 – 14			HV-P7			
	15 – 16			HV-P8			
Output	1		AO 0		INT16	Analog output signals AO 0 – AO 7	
	2		AO 1				
	3		AO 2				
	4		AO 3				
	5		AO 4				
	6		AO 5				
	7		AO 6				
	8		AO 7				

MODBUS interface description

3.8.2 DIM, DIM+CF (9470/.. 9471/.. 9472/..)

On the modules 9470, 9471 and 9472 the inputs 14 and 15 can optionally be used as digital- (DI), counter- (C) or frequency input (F).

Through selection of different module descriptions the transmitted data area on MODBUS can be chosen.

module selection text	Input data [Register]	Output data [Register]	CF Channels	available signal types	
DIM 16 (9470/.. , 9471/..)	1 (16 Bit DI)	-	-	DI without status	
9470 / .. -16-1. DIM 16 ... 9471 / .. -16-1. DIM 16 ...	2 (16 Bit DI + 16 Bit status)	-	-	DI with status	
9470 / .. -16-1. DIM 16+CF ... 9471 / .. -16-1. DIM 16+CF ...	4 (16 Bit DI + 16 Bit status + 2 words CF)	1 (control register for counter)	14 - 15	DI and CF (Counter or Frequency) with status	
9470/3x-16-xx 9471/35-16-xx 9472/35-16-xx	DIM 16	2	0	-	DI with Status
	DI/DO 16	2	2	-	DI or DO with status
	DI/DO 16+2CF	4	4	14 - 15	DI and CF or DO with status
	DI/DO 16+6CF	8	4	10 - 15	
	DI/DO 16+8CF	10	4	8 - 15	

Signal definition with Parameter 'Invert all inputs of the module = No':

9470/ ...	9471/ ...	
$I < 0,05 \text{ mA}$	-	open circuit alarm
$I < 1,2 \text{ mA}$	$U < 5 \text{ V}$	Signal = 0
$I > 2,1 \text{ mA}$	$U > 13 \text{ V}$	Signal = 1
$R_L < 100 \text{ Ohm}$	-	short circuit alarm

Even if DIM 16+CF (with counter / frequency) is selected the inputs 14 and 15 are mapped to the standard DI data area (byte 2) and therefore can be used as standard DI inputs.

Status allocation:

Status Bit	Signal	
0	disturbed	
1	OK	

Signals and states are generated and transmitted synchronized and consistent if parameter 'Error detection' = On

MODBUS interface description

Data

Data	Register	all DIM (947x/3x in compatible mode)			DIOM 9470/3x, 9471/35, 9472/35 (IS1+)					Type	
		DIM	DIM +Stat	DIM +2CF	DIM	DI/DO	DI/DO +2CF	DI/DO +6CF	DI/DO +8CF		
Input	1	DI signals 0 – 15 *1)								BitStr	
	2	Signal Status 0 – 15									
	3			C/F I14			C/F S15	C/F S15	C/F S15	UINT16 (UINT32)	
	4			C/F I15			C/F S14	C/F S14	C/F S14		
	5							C/F S13	C/F S13		
	6							C/F S12	C/F S12		
	7	-	-	-	-	-	-	C/F S11	C/F S11		
	8							C/F S10	C/F S10		
	9								C/F S9		
	10								C/F S8		
Output	1			*2)		DO 0 - 7	DO 0 - 7	DO 0 - 7	DO 0 - 7	BitStr	
				0		0	0	0	0		
	2					DO 8 - 15	DO 8 - 15	DO 8 - 15	DO 8 - 15		
						0	0	0	0		
	3						Reset C14-15	Reset C10-15	Reset C8-15		
							0	0	0		
							Start/Stop C14-15	Start/Stop C10-15	Start/Stop C8-15		
							0	0	0		
4											

*1) In operation mode DI/DO and parametrization as DO written output values can be read back via the dedicated DI signals.
In operation mode DI/DO and parametrization as DI the dedicated DO signals have no effect.

Output Data DI/DO+xCF

Byte	Bit	DO		Reset Counter		Start/Stop Counter	
Low	0	DO 0/8	0 = output high impedance (actuator = Off) 1 = output powered (actuator = On)	Reset C8	0 = Run, 1 = Reset (Counter = 0)	Start/Stop C8	0 = Counter Run 1 = Counter Stop
	1	DO 1/9		Reset C9		Start/Stop C9	
	
	6	DO 6/14		Reset C14		Start/Stop C14	
	7	DO 7/15		Reset C15		Start/Stop C15	
High	0 - 7	0 (Reserved)					

*2) Output Data DIM+2CF:

Byte	Bit	Function	
Low	0	Reset Counter S14	0 = Run, 1 = Reset (Counter = 0)
	1	Reset Counter S15	
	2	Start/Stop S14	0 = Counter Run, 1 = Counter Stop
	3	Start/Stop S15	
	4 - 7	0 (Reserved)	
High	0 - 7	0 (Reserved)	

MODBUS interface description

Operation mode 'counter'

- Count mode: Incremental / decremental with overflow / underflow
- Count event: Positive / Negative edge selectable.
- Signal in case of error: freeze last value (Initial value 0)
- Alarming: Status and channel diagnosis
- Reset: Reset counter register to '0'
- Start/Stop: in 'Stop' mode input pulses are ignored (not counted)

all DIM with counter (9470/3x in comp. mode)	DIOM 9470/3x (IS1+)	count range	count event
Counter 16 Bit		UINT16 0 – 65535	Increment on edge
-	Up/Down Counter 16 Bit		Increment / Decrement depending on rotation direction
-	Up/Down Counter 32 Bit	UINT32 0 – 4.294.967.295	

Counting and rotation direction detection:

For counting and frequency measurement with direction detection two I are used as a functional pair. The phase shift of the two signals is meas The mechanical positioning of the two sensors must be chosen to ensure the overlapping of associated pulses.

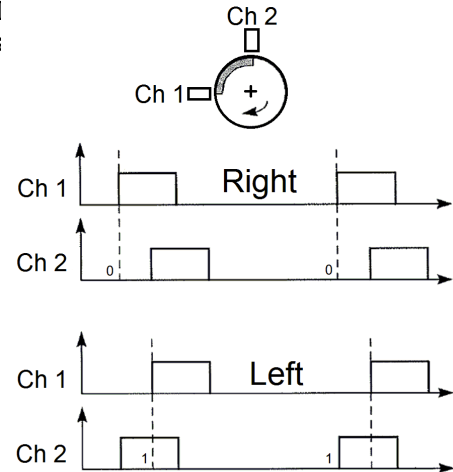

Operation mode	Application
Up/Down Counter	Up- or down counting of incoming pulses depending on direction
Frequency with direction	Rotation frequency and direction detection for rotating machines

Signal allocation in cyclic Input data in operation mode Up/Down Counter or Frequency with direction:

Input data	Usage
first DI bit of a input pair	DI digital value of first input
second DI bit of a input pair	Rotation direction 0 = Right / forward (Pulse on first input comes first) 1 = Left / backward (Pulse on second input comes first)

MODBUS interface description

Signal and status in operation mode 'counter':

Counters are set to 0 during IOM startup.

The status bit is initialized with '0' = signal disturbed.

With the Reset bit in the control register the counter register is set to '0' and the status bit is set to '1' = signal OK.

In case of errors (short circuit, open circuit, bus failure ...) the status bit is set to '0' and will be held at '0' until the next Reset. Therefore disturbances during the count procedure are recognizable via the status bit.

In case of lost Data Exchange with the AS and recover within the parameterized output hold time or in case of CPU redundancy switch over the count procedure will not be disturbed.

Using an input pair in operation mode Up/Down counter or frequency with direction the status bits of both channels are set to 0 = bad in case of a signal error of one of the two channels.

For **summation of 16 Bit counters** in the AS the count difference of two consecutive read cycles must be added from the AS. Counter overflow / underflow must be detected and considered. Maximum one overflow / underflow within one AS cycle shall occur.

32 Bit counter with direction input

For counting without direction detection only the first input of a 32 Bit Up/Down Counter channel pair shall be used. The direction bit must not be used by PLC in this case. Error detection of the second not used input channel shall be set to Off. Pulses on the first input will increment the counter if the second input is open.

Pulses on the first input will decrement the counter if the second input is shorted.

Operation mode 'Frequency'

Module	Max. number signals per module	Operation mode	Measurement method	Scaling [Hz / Bit]	Resolution [Hz]
all DIM with Frequency-measurement (9470/3x in comp. Mode)	2	Frequency 1 Hz - 1 kHz	Pulse time measurement	0,05	+/- 0,05
		Frequency 20 Hz - 20 kHz	Gate time 50 ms	1	+/- 20
		Frequency 5 Hz - 20 kHz	Gate time 200 ms	1	+/- 5
		Frequency 1 Hz - 20 kHz	Gate time 1 s	1	+/- 1
DIOM 9470/3x, 9471/35, 9472/35 (IS1+)	8	Frequency 0,1 - 600 Hz	Pulse time measurement	0,01	+/- 0,01
		Frequency 1 Hz - 3 kHz		0,05	+/- 0,05
		Frequency 1 Hz - 20 kHz		0,5	+/- 0,5
	4 pairs	Frequency 1 Hz - 20 kHz with direction		0,5	+/- 0,5

MODBUS interface description

Signal scaling:

all DIM with Frequency measurement (9470/3x in compatible mode):					
Measuring range		Units		% *1)	Range
1 Hz – 1 kHz	x – 20 kHz	decimal	hex		
1,3 kHz	-	26000	6590	130 %	Over range
1,1 kHz	22 kHz	22000	55F0	110 %	
1 kHz	20 kHz	20000	4E20	100 %	Nominal range
500 Hz	10 kHz	10000	2710	50 %	
0 Hz	0 kHz	0	0	0 %	

DIOM 9470/3x, 9471/35, 9472/35 (IS1+)						
Measuring range			Units		% *1)	Range
0,1 Hz – 600 Hz	1 Hz – 3 kHz	1 Hz - 20 kHz	Dec.	Hex		
> 655,34 Hz	> 3,276 kHz	-	65535	0xFFFF		Overflow
655,34 Hz	3,276 kHz	-	65534	0xFFFE	164 %	Over range
600 Hz	3 kHz	-	60000	0xEA60	150 %	Nominal range
440 Hz	2,2 kHz	22 kHz	44000	0xABE0	110 %	
400 Hz	2 kHz	20 kHz	40000	0x9C40	100 %	
500 Hz	1 kHz	10 kHz	20000	0x4E20	50 %	
0 Hz	0 kHz	0 kHz	0	0x0000	0 %	

*1) Scaling of frequency measurements in IS1 DTM und IS Wizard:

all DIM with Frequency (9470/3x in comp. mode)	Phys. 0 – 100% correlate digital 0 – 20000
DIOM 9470/3x (IS1+)	Phys. 0 – 100% correlate digital 0 – 40000

Signal in case of error: freeze (Initial value 0)
 Diagnosis: status und channel diagnosis

Behavior in case of too high input frequencies:

If the input frequency is higher than the maximum of the selected measurement range, input pulses can be lost. In this case the measured value is smaller as the existing frequency at the input. No alarm is generated.

Signal Filter:

The measured frequency signal can be filtered by the DIOM 9470/3x to reduce jitter. Additionally a pulse extension function is executed for the DI signals.

Parameter	Selection	Pulse extension for DI signals	Filter / smoothing for frequency measurement
Pulse extension / Frequency Filter	0 s / off	0 s	off
	0,6 s / small	0,6 s	small
	1,2 s / medium	1,2 s	medium
	2,4 s / large	2,4 s	large

MODBUS interface description

Pulse extension:

This function can be used to increase the length of short pulses. With this e.g. a short activity of a manual sensor (term approx. 10 .. 50 ms) can be extended to a time selectable by parameterization (T = 0,6 sec., 1.2 sec., 2.4 sec.).

Short pulses can be recognized surely from the AS also with slower cycle times of the application software

Pulse extension with not inverted operation:

(Parameter 'Invert all inputs of the module' = No)

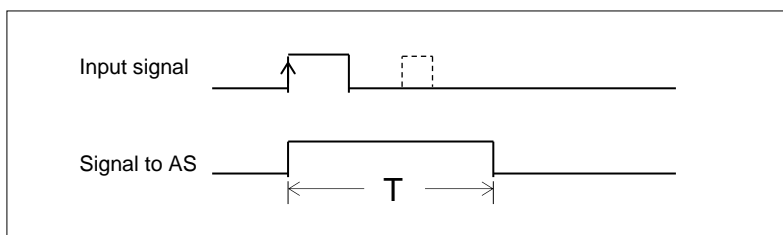

T = 0,6 sec., 1,2 sec., 2,4 sec.

Pulses which are longer than the parameterized time T, are not extended.
Short pulses during time T are suppressed.

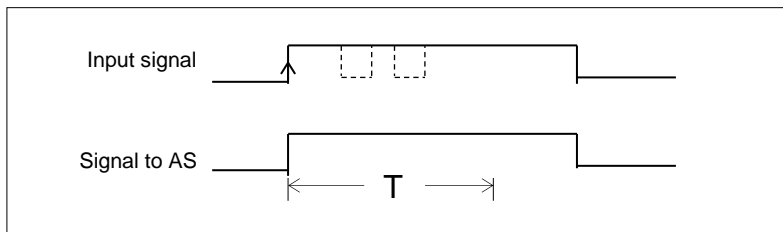

Pulse extension with inverted operation:

(Parameter 'Invert all inputs of the module' = Yes)

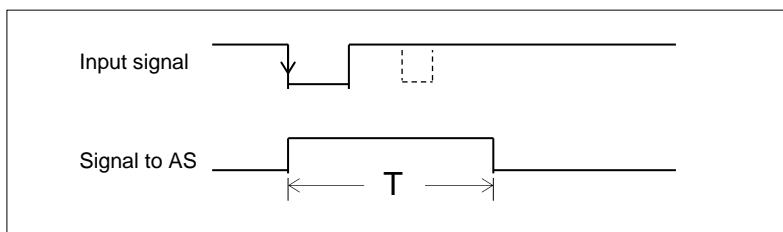

Signal LEDs:

DIOM with signal LEDs display the extended 'Signal to AS'.

MODBUS interface description

3.8.3 DOM (9475/..., 9477/..., 9478/..)

Signal allocation

Data	Register	Byte	Bit	DOM 8 + Status	DOM 4 + Status	DOM 8	DOM 6	DOM 4
				9475/3x	9475/3x			
Input	1	1	0	Status_S0	Status_S0		-	
			1	Status_S1	Status_S1		-	
			2	Status_S2	Status_S2		-	
			3	Status_S3	Status_S3		-	
			4	Status_S4	0		-	
			5	Status_S5	0		-	
			6	Status_S6	0		-	
		7	Status_S7	0		-		
		2	0-7	0	0		-	
Output	1	1	0	DO 0	DO 0	DO 0	DO 0	DO 0
			1	DO 1	DO 1	DO 1	DO 1	DO 1
			2	DO 2	DO 2	DO 2	DO 2	DO 2
			3	DO 3	DO 3	DO 3	DO 3	DO 3
			4	DO 4	0	DO 4	DO 4	0
			5	DO 5	0	DO 5	DO 5	0
			6	DO 6	0	DO 6	0	0
		7	DO 7	0	DO 7	0	0	
		2	0-7	0	0	0	0	0

signal bit = 0	signal bit = 1	Type
output high impedance (actuator = Off)	output is powered according type specification (actuator = On)	DOM
relay contact = open	relay contact = closed	DOMR
Valve closed	Valve open	DOMV

status bit	signal	
0	disturbed	
1	OK	

MODBUS interface description

3.9 Signal behavior in case of errors

3.9.1 Behavior of the input signals in case of errors

If no valid signal value can be formed as a result of a malfunction (short circuit, open circuit, defective subassembly...), an item of diagnostics information is created which can be read via the IS1 DTMs or IS Wizard. Despite the outstanding malfunction, cyclic data including signal status information continues to be transmitted to the AS.

The behavior of the signal values transmitted if a malfunction has occurred can be selected separately for every module by setting parameters (see [I/O module parameters](#)).

Application hint:

If the behavior of input signals in case of errors is realized through the IS1 system, this behavior seen from the application software in the automation system can only be guaranteed with correct communication on MODBUS.

In the event of the failure of the MODBUS additional project specific reactions must be realized in the application software.

To guarantee the same behavior of all input signals in the event of an error, we recommend the following procedure:

Generate a status bit for each input signal in the automation system:

- Signal Status information for all signal types of IS1 IOM can be read via register 13 to 28. (see [Signal status](#))
- for DI signals and for all signals of IS1+ IOMs (FW 03-xx) the signal status bits available optionally from IS1 may be used in the input data area. (see [Data word structure of the I/O modules](#))
- for AI signals optionally the behavior in case of error = 'Status Code' may to be chosen in the parameters of all AI signals (default). In the application software of the automation system the following function has to be used for each AI signal:

```

If SignalValue >= 32512 Or SignalValue <= -32512 then
    SignalStatusBit = disturbed
Else
    SignalStatusBit = OK
End IF
    
```

The signal behavior in case of an error (freeze, substitute value ...) can now be realized in the automation system controlled by the related status bit.

In this case the event 'Slave failure on MODBUS' can be logical linked to the signal status whereby the signal behavior in case of an error is always the same under all error conditions.

To generate alarm messages for output modules, in the automation system one bit per module (module alarm bit) can be read from the IS1 CPU to generate messages (see [Module alarms](#)). The details on the diagnostics information should be read and displayed via the IS1 DTMs or IS Wizard.

MODBUS interface description

3.9.2 Behavior of the output signals in case of errors

Communication error between the master and IS1+ field station:

The cyclic data traffic between the MODBUS TCP client and IS1 is checked using response monitoring in the IS1+ CPU.

Response monitoring in the CPU makes sure that if the master suffers a failure or there is some other communication loss to the master after expiry of the time (T_{WD}), all output registers are set to 0x8000H and the outputs adopt the safe state. The allocated Ethernet connection will be closed and is then enabled for use for other MODBUS clients.

The T_{WD} (Watchdogtime AS interface) time parameter can be set in the range 100 ms to 25.5 seconds ,(default = 2 sec.).

The response monitoring of the slaves can also be deactivated ($T_{WD}=0$). In this case, a loss of communication to the master cannot be recognized. The output signals from the field stations are frozen if updating from the master cannot be performed.

Communication error between the CPU and output module:

There are watchdog circuits on the output modules that monitor the data transmission between the CPU and the output modules. If an output module does not receive any valid data for more than T_{Mod} , the subassembly adopts the safe setting.

T_{Mod} (timeout for output modules) parameter can be set in the range 100 ms to 25.5 sec. (default value: 1 s).

Consequently, the safe setting for the output modules follows at a delay of T_S after failure of the communication to the master where:

$$T_S = T_{WD} + T_{Mod}$$

Application Hint:

In unstable Ethernet Networks short interruptions of Modbus connections with automatic restart of the connections may occur with the result, that IS1 output signals go to safe position during such disturbances of communication. Network wiring and communication quality shall be checked and improved in such cases.

To improve robustness of the output signals against such short communication interruptions the parameter 'communication timeout for output modules' T_{Mod} should be set:

$$T_{Mod} > \text{Max. AS Update cycle for writing output data} + 10\%$$

Output signals will be frozen during the disturbances with this setting.

The safe setting parameter for the output signals can be set separately for each module (see [IOM Parameter](#)).

MODBUS interface description

3.10 HART variables

In addition to the analogue process value, HART field devices offer the option of digitally reading up to four process variables (HART variables HV) from the transmitter.

Routed HART Variables

IS1 offers the option of mapping routed HART variables to the cyclic input data area of MODBUS.

Optionally, no HART variables, four or eight HART variables of an IS1 HART module (AIMH, AUMH, AOMH) can be routed and transmitted in addition to the cyclic data.

This can be selected optionally when configuring a field station.

Modbus Mapping of the extended HART data

With IS1+ 9442 CPUs or IS1 9441 CPUs, firmware from V21-19 together with 9468 AUMH from Rev. V03-06 or 9469 UMH, all 32 HV from the max. 8 HFD of one IS1 IOMH and additional variable- und HART device stati can be read via separate Modbus register areas. This additional HART data is available in parallel to the above mentioned routed option.

Supply of HART devices using Analog Universal Module AUMH 9468/3x or 9469 UMH

Each channel of an AUMH or UMH can be parametrised as analog input for HART sensors or as analog output for HART actuators. The supply of HART sensors and HART actuators is different and will be switched too.

For communication with a HART sensor the channel shall be parameterized as 'Input'.

For communication with a HART actuator the channel shall be parameterized as 'Output'.

In a non parameterized state the channels are in the position 'Output' and HART communication is possible with HART actuators only.

Availability of HART Variables and acyclic HART communication:

Configuration	Parameter	routed +4/ +8 HV	not routed 32 HV	acycl. HART	polling HV from AUMH/UMH
no config	no parameter	-	Yes, HART actuators only	Yes, HART actuators only	Yes
9468/9469 no HV	Livelist = OFF	-	-	Yes	No
	Livelist = ON	-	Yes	Yes	Yes
9468/9469 + HV	HV mapping	Yes	Yes	Yes	Yes

MODBUS interface description

3.10.1 Module selection in IS1 DTM

Module selection text	Length cyclic data [bytes]		Number of HART variables (HVs) transmitted via routing
	Input	Output	
9461/12-08-11 AIMH8 2w Exi	16	0	None
9461/12-08-11 AIMH8+4HV 2w Exi	32	0	4 HV
9461/12-08-11 AIMH8+8HV 2w Exi	48	0	8 HV
9461/12-08-21 AIMH8 Exi	16	0	None
9461/12-08-21 AIMH8+4HV Exi	32	0	4 HV
9461/12-08-21 AIMH8+8HV Exi	48	0	8 HV
9466/12-08-11 AOMH8 Exi	0	16	None
9466/12-08-11 AOMH8+4HV Exi	16	16	4 HV
9466/12-08-11 AOMH8+8HV Exi	32	16	8 HV
9468/3x-08-xx 8AIH +4HV	34	0	4 HV
9468/3x-08-xx 8AOH +4HV	18	16	
9468/3x-08-xx 8AIH/8AOH +4HV	34	16	
9468/3x-08-xx 8AIH +8HV	50	0	8 HV
9468/3x-08-xx 8AOH +8HV	34	16	
9468/3x-08-xx 8AIH/8AOH +8HV	50	16	
9469/35-08-xx 8IH Exn	9	0	None
9469/35-08-xx 8OH Exn	1	8	
9469/35-08-xx 6IH+2OH Exn	7	2	
9469/35-08-xx 8IH/8OH Exn	9	8	
9469/35-08-xx 8IH +4HV Exn	17	0	4 HV
9469/35-08-xx 8OH +4HV Exn	9	8	
9469/35-08-xx 8IH/8OH +4HV Exn	17	8	
9469/35-08-xx 8IH +8HV Exn	25	0	8 HV
9469/35-08-xx 8OH +8HV Exn	17	8	
9469/35-08-xx 8IH/8OH +8HV Exn	25	8	

3.10.2 Data format

HART variables are transmitted as IEEE floating-point numbers (4 bytes).

If a HART variable cannot be read (e.g. HART device undergoing startup, not connected, defective or HART variable not found, ...), value 7F A0 00 00 (Not a Number) is transmitted. This may be evaluated in the AS for generation of a signal status of the HART variables. Detailed status and diagnostic information on the HART field devices can be evaluated via HART Management Systems.

The sequence of the two registers of one HART variable is used different in AS systems.

The IS1+ 9442 CPU supports both format variants 'float' (default) and 'swapped float' for all HART data. 9440 and 9441 CPUs support format switching for HART Variable registers from address of 3001 only.

Selection of Float Format see [CPU parameters](#).

MODBUS interface description

3.10.3 Routed HART Variables

Up to 8 HART field devices can be connected to one HART module of IS1. Since each HART field device may have up to 4 variables, this mean that a maximum of 32 HART variables are possible per IS1+ HART module.

The assignment (routing) of 4 or 8 out of these 32 variables to the positions P1 to P8 in the cyclic transmission area can be selected by parameter assignment:

Parameter name	Value range	Function
Input No. HART device for pos. 1	0 ... 7, Not used	Selection of the channel No. (input / output No.) of the HART module to which the HART field device is connected which is to be transmitted at pos. 1. If 'Not Used' is selected, value 'Not a Number' (7F A0 00 00) is transmitted.
Input No. HART device for pos. 2		Selection for pos. 2
.....	
Input No. HART device for pos. 4 (8)		Selection for pos. 4 (8)
HART variable for pos. 1	1 ... 4	Selection of the variables of the HART field device which is to be transmitted at pos. 1.
HART variable for pos. 2		Selection for pos. 2
.....	
HART variable for pos. 4 (8)		Selection for pos. 4 (8)

MODBUS interface description

3.10.4 Modbus Mapping of the extended HART data

Reg	Data	Slot	Channel	Dyn. HV		
5001	HV [Float]	1	0	1 (PV)		
5002	HV [Float]			2 (SV)		
5003	HV [Float]			3 (TV)		
5004	HV [Float]			4 (QV)		
5005	DV Status			1 (PV)		
5006	DV Status			2 (SV)		
5007	DV Status			3 (TV)		
5008	DV Status			4 (QV)		
5009	HV [Float]			2	1	1 (PV)
5010	HV [Float]					2 (SV)
5011	HV [Float]					3 (TV)
5012	HV [Float]					4 (QV)
5013	DV Status	1 (PV)				
5014	DV Status	2 (SV)				
5015	DV Status	3 (TV)				
5016	DV Status	4 (QV)				
5017	HV [Float]	3	2			1 (PV)
5018	HV [Float]					2 (SV)
5019	HV [Float]					3 (TV)
5020	HV [Float]					4 (QV)
5021	DV Status			1 (PV)		
5022	DV Status			2 (SV)		
5023	DV Status			3 (TV)		
5024	DV Status			4 (QV)		
5025	HV [Float]			4	3	1 (PV)
5026	HV [Float]					2 (SV)
5027	HV [Float]					3 (TV)
5028	HV [Float]					4 (QV)
5029	DV Status	1 (PV)				
5030	DV Status	2 (SV)				
5031	DV Status	3 (TV)				
5032	DV Status	4 (QV)				
5033	HV [Float]	5	4			1 (PV)
5034	HV [Float]					2 (SV)
5035	HV [Float]					3 (TV)
5036	HV [Float]					4 (QV)
5037	DV Status			1 (PV)		
5038	DV Status			2 (SV)		
5039	DV Status			3 (TV)		
5040	DV Status			4 (QV)		
...
5085	HV [Float]			16	7	1 (PV)
5086	HV [Float]					2 (SV)
5087	HV [Float]					3 (TV)
5088	HV [Float]	4 (QV)				
5089	DV Status	1 (PV)				
5090	DV Status	2 (SV)				
5091	DV Status	3 (TV)				
5092	DV Status	4 (QV)				
5093	HV [Float]	17	0			1 (PV)
5094	HV [Float]					2 (SV)
5095	HV [Float]					3 (TV)
5096	HV [Float]					4 (QV)
5097	DV Status			1 (PV)		
5098	DV Status			2 (SV)		
5099	DV Status			3 (TV)		
5100	DV Status			4 (QV)		
5101	HV [Float]			18	1	1 (PV)
5102	HV [Float]					2 (SV)
5103	HV [Float]					3 (TV)
5104	HV [Float]					4 (QV)
5105	DV Status	1 (PV)				
5106	DV Status	2 (SV)				
5107	DV Status	3 (TV)				
5108	DV Status	4 (QV)				
...
6536	DV Status	16	7			4 (QV)

4 HART Variables (PV, SV, TV, QV) from HART field devices are mapped in sequence from Modbus Input Register 5001 followed by Device Variable Stati (DV Status) of the 4 HV in separate Modbus Registers each.

This structure is available for all HART field devices on all channels of IS1+ 9468 or 9469 HART modules.

See example left.

HART Data from Reg. 5001 can be read via Modbus functions 03 (holding register) or 4 (input register) optionally.

The address of the first register of each HV can be calculated:

$$\text{REG_ADR_HV} = 4999 + (\text{Slot}-1) * 96 + \text{Channel} * 12 + \text{HV} * 2$$

HART Device Status

Reg.	Slot	Kanal		
6617	1	0	DEVSTATUS	
6618		1	DEVSTATUS	
6619		2	DEVSTATUS	
6620		3	DEVSTATUS	
6621		4	DEVSTATUS	
6622		5	DEVSTATUS	
6623		6	DEVSTATUS	
6624		7	DEVSTATUS	
6625		2	0	DEVSTATUS
6626			1	DEVSTATUS
6627			2	DEVSTATUS
....		
6744	16	7	DEVSTATUS	

(128 Register)

HART Extended Device Status

Reg.	Slot	Kanal		
6745	1	0	EXTDEVSTATUS	
6746		1	EXTDEVSTATUS	
6747		2	EXTDEVSTATUS	
6748		3	EXTDEVSTATUS	
6749		4	EXTDEVSTATUS	
6750		5	EXTDEVSTATUS	
6751		6	EXTDEVSTATUS	
6752		7	EXTDEVSTATUS	
6753		2	0	EXTDEVSTATUS
6754			1	EXTDEVSTATUS
6755			2	EXTDEVSTATUS
....		
6872	16	7	EXTDEVSTATUS	

(128 Register)

MODBUS interface description

HART Unit Code

Reg.	Slot	Channel	Dyn. HV	Unit	
7001	1	0	1 (PV)	Unit code	
7002			2 (SV)	Unit code	
7003			3 (TV)	Unit code	
7004			4 (QV)	Unit code	
7005		1	1 (PV)	Unit code	
7006			2 (SV)	Unit code	
7007			3 (TV)	Unit code	
7008			4 (QV)	Unit code	
7009		2	1 (PV)	Unit code	
7010			2 (SV)	Unit code	
7011			3 (TV)	Unit code	
....			4 (QV)	
....		
7032		7	4 (QV)	Unit code	
...	
7512		16	7	4 (QV)	Unit code

(512 Registers)

HART Engineering Unit Codes see HCF / FCG SPEC-183 Tab. 5.2

Extract from HCF / FCG Spec-183 Tab. 5.2:

Unit Code [dec]	Unit
7	bar
8	mbar
32	°C
36	mV
37	Ohm
39	mA
41	Liter
45	Meter
49	mMeter
58	V
59	pH
127	kW
128	kWh
163	kOhm

Reaction in IOMH in case of no or disturbed communication to the HFD:

- HV = Not a number (0x7F A0 00 00)
- HART Live List (Device Bit) = 0 (No Response)
- DV Status = 0x00 (Bad)
- DEVSTATUS = 0x00 (no errors)
- EXTDEVSTATUS = 0x08 (Failure)
- UNIT = 0x00 (No Unit specified)

DV Status:

DV Status = good (0xc0) if HV Variable is readable.

DV Status = Bad (0x00) if HV Variable is not readable.

DEVSTATUS: see HCF / FCG SPEC-183 ANNEX A

EXTDEVSTATUS:

Contains NAMUR NE107-compatible Condensed Status information.

EXTDEVSTATUS -> Can be read only from device with HART7+.

From HART6 only Bits 0 and 1 are supported.

Delivers information from a responding HFD.

If HFD is not responding or EXTDEVSTATUS is not supported by HFD the IOMH will set:

- EXTDEVSTATUS = Good (0x00) if HV Variable is readable.
- EXTDEVSTATUS = Failure (0x08) if HV Variable is not readable.

HART Condition Monitoring

For easy Condition Monitoring of HART field devices the EXTDEVSTATUS of all HFD can be read by the AS in a slow cycle. Operator warnings may be generated in the AS if required.

In case of error the maintenance personal can check the affected HFD e. g. via FDT for details and perform maintenanc actions if required.

MODBUS interface description

HCF / FCG SPEC-183 Tab. 17 EXTDEVSTATUS
(Contains NAMUR NE107-compatible Condensed Status):**Code Description**

- 0x01 **Maintenance Required.** [*Condensed Status*] This bit is set to indicate that, while the device has not malfunctioned, the Field Device requires maintenance. Devices supporting this bit should support the Condensed Status Commands (see *Common Practice Command Specification*).
- 0x02 **Device Variable Alert.** This bit is set if any Device Variable is in an Alarm or Warning State. The host should identify the Device Variable(s) causing this to be set using the Device Variable Status indicators.
- 0x04 **Critical Power Failure.** For devices that can operate from stored power. This bit is set when that power is becoming critically low. For example, a device scavenging power loosing that power source would set this bit. Devices must be able to sustain their network connection for at least 15 minutes from the when this bit is set. A device may begin gracefully disconnecting from the network if its power level drops too low.
- 0x08 **Failure.** [*Condensed Status*] When this bit is set one or more Device Variables (i.e., measurement or control values) are invalid due to a malfunction in the field device or its peripherals. Devices supporting this bit must support the Condensed Status Commands (see *Common Practice Command Specification*).
- 0x10 **Out of Specification.** [*Condensed Status*] When set, this bit indicates deviations from the permissible ambient or process conditions have been detected that may compromise measurement or control accuracy (i.e., device performance may be degraded given current operating conditions). Devices supporting this bit must support the Condensed Status Commands (see *Common Practice Command Specification*).
- 0x20 **Function Check.** [*Condensed Status*] This bit is set if one or more Device Variables are temporarily invalid (e.g. frozen) due to ongoing work on the device. Devices supporting this bit must support the Condensed Status Commands (see *Common Practice Command Specification*).

MODBUS interface description

3.10.5 HART Livelist

View in IS1 DTM:

HART Livelist

Slot	Channel							
	0	1	2	3	4	5	6	7
1	✓	✓	—	—	✓	✓	✓	—
2								
3	—	—	—	—	—	—	—	—
4	✓	✓	✓	✓	✓	✓	✓	✓
5	🔄	🔄	🔄	🔄	🔄	🔄	🔄	🔄
6	✓	✓	✓	✓	✓	✓	✓	✓
7								
8								
9								
10								
11								
12								
13								
14								
15								
16								

Description

This dialog represent the state of all channels of an IS1 STAHL Remote I/O. Refresh cycle: 1s (new devices up to 15s).

Legend

- ✓ HART communication OK
- No response from HART
- Scan deactivated
- No HART module detected
- 🔄 Reset IOM

Refresh State

● CPM Online ● Refresh

Overview of the status of all HART field devices (HFD) connected to one IS1+ Field station for simplified commissioning and maintenance.

For further information for use of the IS1 DTMs see operating instructions 'DTM IS1 Mod'.

Read via MODBUS TCP:

HART Live List		
Modbus Register	Slot	Livelist
6601	1	
6602	2	
6603	3	
6604	4	
6605	5	
6606	6	
6607	7	
6608	8	
6609	9	
6610	10	
6611	11	
6612	12	
6613	13	
6614	14	
6615	15	
6616	16	

One Bit per HART field device connected to channel 0-7 in the Bits 0-7 in the Low Byte of a Register for each IS1 module IOMH.

0 = No Response
1 = HFD responding

Function available with IS1 9441 CPU firmware from V21-19 and with all 9442 CPUs.

MODBUS interface description

3.11 IS1 DTMs

Configuration, parameter setting, diagnostics and HART communication for the IS1+ field stations is handled via the IS1 DTMs using FDT technology.

Example: Signals / Diagnostics

9465/12-08-11
IS1 IOM Slot 3
9440/15-01-11 CPM Z2 24V Stahl PROFIBUS DP

Signals / Diagnoses IOM

Diagnoses

Icon	Name	Value
<input checked="" type="checkbox"/>	Module diagnosis	Communication to IOM OK

Signals

No.	Tag	Metered Value(int)	Metered Value(phys)	0%	50%	100%	Unit	Diagnoses
0	AD 0	553	2,0001	<input type="radio"/>	<input type="radio"/>	<input type="radio"/>	%	
<input checked="" type="checkbox"/> 1	AD 1	144	0,5208	<input type="radio"/>	<input type="radio"/>	<input type="radio"/>	%	Short circuit
2	AD 2	-32768	Value underflow	<input type="radio"/>	<input type="radio"/>	<input type="radio"/>	%	
3	AD 3	9400	33,998	<input type="radio"/>	<input type="radio"/>	<input type="radio"/>	%	
4	AD 4	15483	56,000	<input type="radio"/>	<input type="radio"/>	<input type="radio"/>	%	
5	AD 5	-32768	Value underflow	<input type="radio"/>	<input type="radio"/>	<input type="radio"/>	%	
6	AD 6	27095	97,999	<input type="radio"/>	<input type="radio"/>	<input type="radio"/>	%	
7	AD 7	27648	100,00	<input type="radio"/>	<input type="radio"/>	<input type="radio"/>	%	

Close

For further information on the use of the IS1 DTMs see operating instructions 'DTM IS1 Mod'.

MODBUS interface description

3.12 Webserver

Webserver are integrated in the IS1+ 9441 and 9442 CPUs which offer additional diagnostic functions for commissioning, maintenance and OEM service support.

Access via standard WEB browsers with: `http://xxx.xxx.xxx.xxx` (xxx.xxx.xxx.xxx = IP-SB Address IS1+ CPU)

3.12.1 Webserver 9141 CPU

Example 9441 CPU: MODBUS

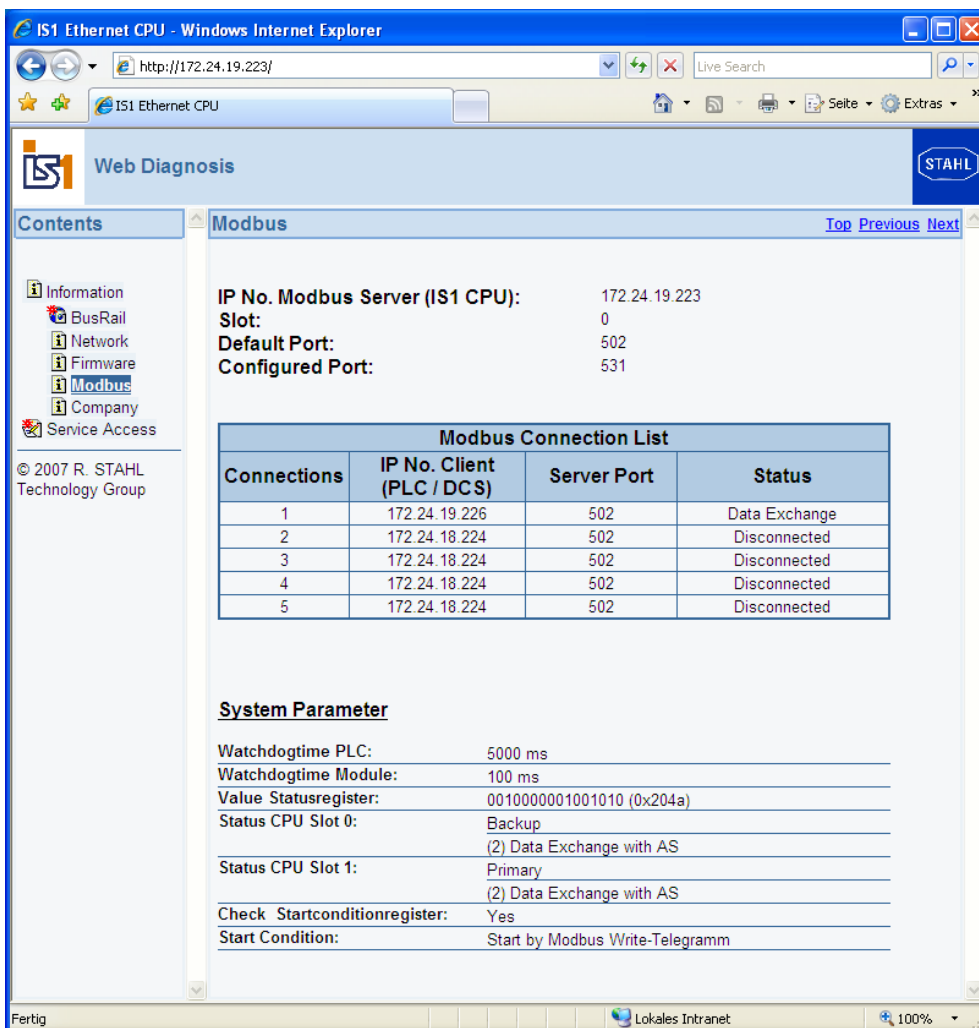

Status	Description
Data Exchange	Connection is in cyclic data exchange and is monitored for timeout. (see Parameter ' Watchdogtime AS Interface T _{WD} ')
Disconnected	Timeout T _{WD} for connection elapsed. Connection not actually in use. The IP address and port no. of the last connected client is displayed.
not used	Connection has not been used since CPU power on.

MODBUS interface description

3.12.2 Webserver 9442 CPU

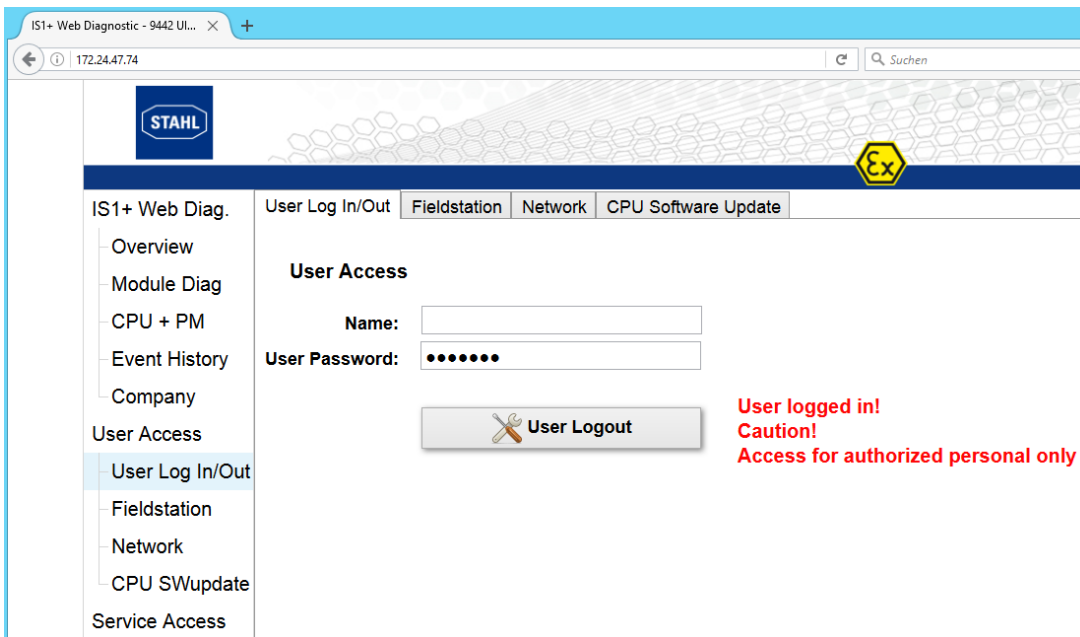

Password and Access concept:

The various menu items of the IS1 + Web server are divided into three groups

Group	Page	Function
IS1+ Web Diagnostic	Diagnostic Overview Plugged Modules Configured Modules Backplanes HART Live List Module Diagnostic System Diagnostic AS- Protocol CPU Parameter License Event History Company	Standard Diagnosis Information – Read Only
User Access	User LogIn/Out Fieldstation Network CPU Software Update	Network Settings and Software Update CPU Without User Passwort: Read Only With User Passwort: Read- und Write of important User Data like IP-Address, Device Name,
Service Access	Service LogIn/Out	Service Information

User Login/Out

The user password by default is set to: **R.STAHL**
 The user shall to change it after a successful user login.

MODBUS interface description

3.13 LED and LCD-displays of the CPUs

The operational state and the communication on the MODBUS can be assessed on site using the LEDs on the CPUs of IS1+ fieldstations.

Additionally the signal values, the signal and module alarms can be displayed on the LCD display on the 9440 CPM and on the socket of 9441 CPUs.

For details, see the operating instructions for 9440 CPM, 9441 or 9442 CPUs.

3.14 Online behavior of the IS1+ field station.

3.14.1 Parameter changes.

If an IS1+ field station is exchanging data with the MODBUS client or master, parameters can be modified in operation (online) via the IS1 DTMs or IS Wizard.

Exception: CPU parameter 'Watchdogtime AS Interface T_{wd}'
See [CPU parameters](#)

3.14.2 Configuration changes.

New or modified configuration data can be loaded to the IS1+ CPU using the IS1 DTMs or IS Wizard during data exchange with the MODBUS client or master.

The mapping of the I/O signals to the MODBUS registers is according the new configuration.

It is therefore to be checked, whether, due to the configuration changes, adjustments in the signal mapping in the automation system are necessary.

The restarted CPU checks the real existing modules (actual state) against the configuration data (target state). All modules of the field station where the configured modules agree with the existing module type in the field station are updated cyclically after start-up.

For modules, which do not agree with the configuration data, alarms are generated. The signals for these modules are not updated and react according the behavior set in the parameters in case of error.

Due to the behavior described above, a field station can be expanded online by adding new modules to the existing modules. In this case the assignment of the signals for the existing modules in the field station to the MODBUS registers is not changed.

Newly added modules are appended to the end of the register area used previously.

Process for online expansion:

- Add new modules (expansions to an existing field station) in free slots on the rail **after** the existing I/O modules.
- Add new modules to configuration offline in FDT frame.
- Online download of the configuration to the CPU while MODBUS is running.
- Expansion of the current messages in the MODBUS TCP client or master with the signals for the newly added modules.

Attention!

An **online change is not possible** if existing modules are changed for other module types and as a result the number of input and output registers at the module slot to be processed changes.

In this case the mapping in the MODBUS Client or Master must be modified which is usually not possible without effects on the running process.

MODBUS interface description

3.15 Transmission time

3.15.1 MODBUS RTU

Transmission time for read telegrams (Functions 01, 02, 03, 04):

$$t [s] = (16 + \text{account DW} * 2) * 11 / \text{Baudrate} \quad *1)$$

Transmission time for write telegrams (Functions 15, 16):

$$t [s] = (20 + \text{account DW} * 2) * 11 / \text{Baudrate} \quad *1)$$

- *1) The above formulas consider the response delay times of the CPM, but not the telegram delay times of the automation system. They are used for calculating the attainable minimum transmission time. Dependent on the telegram delay times of the automation system the actually attainable values are subject to increase.

DW = data words (Registers)

Easy rule of thumb:

Baudrate [Baud]	Transmission capacity on MODBUS
9600	250 Registers / Second
19200	500 Registers / Second
38400	1000 Registers / Second

MODBUS interface description

3.15.2 MODBUS TCP

Total delay of input signals (worst case):

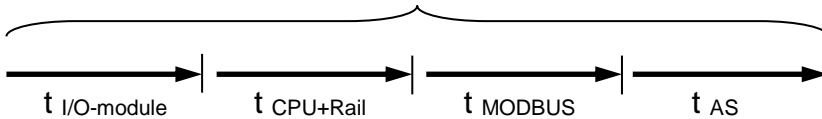

Total delay of output signals (worst case):

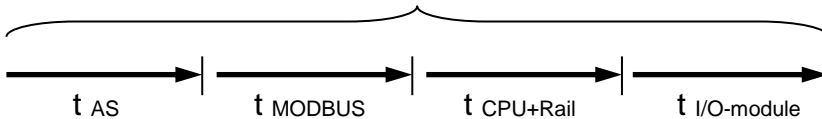

$t_{I/O\text{-module}}$ max. signal delay see operation manual of the different IS1 I/O modules.

$t_{CPU+Rail}$ ca. 4ms + number IOM * 1 ms (9441 CPU from Firmware V21-09)

$t_{MODBUS\ TCP}$

Data Length	1 Register	100 Register	200 Register	16 Coils	800 Coils	1600 Coils
Delay *1)	1,5 ms	2 ms	2,5 ms	1,7 ms	2,6 ms	3,5 ms

*1) typical delay between Request and Response telegram inside of a switched Ethernet network. Using access via Routers or Internet the value will increase.

t_{AS} AS cycle + further delays in automation system (AS)

MODBUS interface description

4 List of abbreviations

AS	A utomation S ystem
AIM	A nalogue I nput M odule
AIMH	A nalogue I nput M odule + H ART
AUMH	A nalog U niversal M odule AI/AO with H ART
SAIMH	S afety A nalogue I nput M odule + H ART (PROFIsafe)
AOM	A nalogue O utput M odule
AOMH	Analogue Output Module +HART
CPM	C PU + PM = CPM Central unit consisting of communication processor with power pack
DIM	D igital I nput M odule
DIOM	D igital I nput O utput M odule
DOM	D igital O utput M odule
DOMR	D igital O utput M odule R elays
DOMV	D igital O utput M odule V alves
HW	Hardware
IOP	I/O P rocessor of the central unit
IOM	General description of I/O M odule
PM	P ower M odule (power pack)
SW	Software
SIL	S afety I ntegrity L evel
TIM	T emperature I nput M odule

FCG	FieldComm Group (former HART Communication Foundation HCF)
HART	Highway Addressable Remote Transducer
PV	Primary Variable
SV	Secondary Variable
TV	Tertiary Variable
QV	Quaternary Variable

MODBUS interface description

5 Release notes:

Version	Extensions / Changes
Interface description MODBUS	
V 1.00	First official release
V1.05	IS1 CPU Redundancy with redundant MODBUS TCP Networks supported.
V1.06	DOMV 9478/22-08-51 supported.
V1.07	From firmware rev. 21-09: <ul style="list-style-type: none"> • Read Input Data optional via MODBUS function 3 with register offset +1000 • Railcommunication timing optimized • Support of read output data from backup CPU with DTM. • Status display of backup CPU in DTM – bug fix.
V1.08	<ul style="list-style-type: none"> • 9480 TIMR Parameters added for CU53 GOST, Pt46 GOST, Pt50 GOST
V1.09	From Firmware 21-11: <ul style="list-style-type: none"> - BootP – IP address setting via BootP Server - ACD Address Conflict Detection
V1.10	Description extended for start condition in case of redundant CPUs
V1.11	Application Hint added in chapter 3.10.2
V1.12	Value for signal status revised
V2.00	IS1+ extension with new IOM 9468, 9470/3x and 9475/3x
V2.01	new IS1+ IOM 9482 TIM added
V2.02	Extended HART Support. Fast transmission of 4 HART variables with stati per HART Fielddevice
V2.03	New IS1+ modules added. <ul style="list-style-type: none"> - 9469/35 UMH Z2 Ex n - 9471/35 DIOM Z2 Ex n - 9472/35 DIOM-24V Z2 Ex n
V3.00_b3	New 9442 Z2 CPU added. MODBUS RTU and TCP combined in one document.

6 Further reading

- [MODBUS MESSAGING ON TCP/IP IMPLEMENTATION GUIDE V1.0b](#)
- [MODBUS APPLICATION PROTOCOL SPECIFICATION V1.1b](#)

Available at: <http://www.MODBUS.org/> -> Technical Resources -> MODBUS Specifications

7 Support address

R. STAHL Schaltgeraete GmbH

Business Unit Automation Interface and Solutions

eMail: support.automation@stahl.de

Support information: www.r-stahl.com

Service hotline IS1: +49 (7942) 943-4123

Fax : +49 (7942) 943-40 4123