

# ExCam<sup>®</sup> Series <sup>2025</sup>



T08  - Installation Manual



## Table of contents

<b>1</b>	<b>Introduction .....</b>	<b>4</b>
<b>2</b>	<b>Technical data .....</b>	<b>4</b>
2.1	Characteristic values for explosion protection .....	4
2.1.1	Optional marking .....	4
2.1.2	Standards basis and certificate .....	5
2.2	Electrical parameters .....	6
2.2.1	Voltage supply: .....	6
2.2.2	Performance, temperatures and temperature classes .....	6
<b>3</b>	<b>General safety instructions and special conditions .....</b>	<b>8</b>
<b>4</b>	<b>Area of application .....</b>	<b>9</b>
<b>5</b>	<b>Packing, transportation and storage .....</b>	<b>10</b>
<b>6</b>	<b>Commissioning .....</b>	<b>11</b>
6.1	Installation .....	11
6.1.1	Types from T08-VA0.1 to VA2.2 .....	11
6.1.2	Type T08-VA2.3 .....	12
6.1.3	Type T08-VA4.x .....	13
6.1.4	Type T08-TNXCD .....	13
6.2	Opening and closing the housing .....	13
6.2.1	Type T08-VAx.x.x.x .....	13
6.2.2	Type T08-TNXCD .....	16
6.3	Electrical connection and commissioning .....	20
6.4	Additional elements (appropriate cables and cable glands) .....	21
<b>7</b>	<b>Problems, hints, solutions .....</b>	<b>22</b>
<b>8</b>	<b>Maintenance/ Modification .....</b>	<b>23</b>
<b>9</b>	<b>Repair .....</b>	<b>23</b>
<b>10</b>	<b>Disposal/ Recycling .....</b>	<b>23</b>
<b>11</b>	<b>Drawings .....</b>	<b>23</b>
<b>12</b>	<b>Certificates .....</b>	<b>24</b>
12.1	EU - Declaration of Conformity .....	24
12.2	UKCA - Declaration of Conformity .....	25
12.3	EU Type Examination Certificate (ATEX) .....	26
12.4	IECEX Certificate of Conformity: .....	26
12.5	EAC-Ex Certificate .....	26
12.6	Other certificates .....	26
<b>13</b>	<b>Notes .....</b>	<b>27</b>

## Table of Figures and Charts

Table 2-1: T08 electrical input supply (T6 and T5) .....	7
Table 2-2: T08 power supply (T4 and T3).....	7
Fig. 6-1: T08-VA1.1 to VA2.2. Mounting options .....	11
Fig. 6-2: T08-VA2.3 Safety wire.....	12
Fig. 6-3: Opening the ExCam T08-VAx.x.x.x camera .....	14
Fig. 6-4: Exception ExCam T08-VA4.1K.PS1.....	14
Fig. 6-5: Removing the countersunk screw, type T08-TNXCD .....	17
Fig. 6-6: Opening the cover flange of type T08-TNXCD .....	18
Fig. 6-7: Position of the O-ring seal, type T08-TNXCD .....	19

## History of revisions

Product:	T08 - ExCam® Series
Title:	EX installation instructions for type 08
Doc. -Id.	180731-PT08BAU-SS-Ex Installation Manual rev.10-stahl.docx
Author:	Steffen Seibert, Grad. Eng. Thiemo Gruber, Grad. Eng.
Created on:	July 31, 2018
Last update:	November 26 <sup>th</sup> , 2025

Rev.- Index	Date	Name	Comment	Approved by the EX Supervisor
00	21.08.2018	T.Gruber S.Seibert	Compilation of the document	
01	04.05.2020	T.Gruber	Enclosure Upgrade 2020: regarding „180619-PT08BAU-SS-Ex-Konzept-2018_rev.05.pdf“, Standards Update	
02	18.08.2021	T.Gruber	Additions to the 2 <sup>nd</sup> supplement to the type examination: device UPGRADE T08-VA0.4.K1.GER	
03	10.03.2022	E. Schneider	Supplements for the Russian certification	
04	28.03.2022	E. Schneider	Correction of the limit values of the electrical power supply for T08-VA4.3.K1.BORx	
05	26.09.2022	S.Seibert	Adding UKCA	
06	23.05.2023	E. Schneider	Additions for opening/closing the housing	
07	05.07.2023	E. Schneider	Change in tightening torque VA4.x	
08	30.05.2024	E. Schneider	Updated declarations of conformity	
09	29.01.2025	E. Schneider	Additional information about flip-Connect	
10	26.11.2025	S.Heinz	Updated EU-declaration of conformity	

# 1 Introduction

The ExCam series (type 08) is an electrical device. It is certified and approved as a pressure-resistant camera system. The cameras may be used in Ex-zones 1, 2, 21 and 22, including the explosion group IIC (for example, acetylene) and IIIC (conductive and combustible dust). Some models are even approved for the mining industry.



Some models of the T08-VA... ExCam series can be used, both as stationary and as mobile explosion-proof camera devices (hand-held use, etc.).

## 2 Technical data

### 2.1 Characteristic values for explosion protection

Identification marks

acc. to Directive 2014/34/EU:

 II 2G (zone 1 and 2)  
 II 2D (zone 21 and 22)  
 I M2 <sup>1</sup>

Explosion protection (gas):

Ex db IIC T6 Gb<sup>1</sup>

Explosion protection (dust):

Ex tb IIIC T80°C Db<sup>1</sup>

Explosion protection (mining):

Ex db I Mb<sup>1</sup>

Protection level:

IP66/68 (IEC/EN 60529)

Date of manufacture (Prod. Year):

see type plate

#### 2.1.1 Optional marking

If necessary, the mining industry marking (ATEX Group 1) can be omitted. \*\*

The explosion group can be downgraded, if necessary. \*\*

The ambient temperature range can be downgraded, if necessary. \*\*

The temperature class/value (gas or dust) can be downgraded, if necessary. \*\*

ix	= for models with intrinsically safe circuits [ix Gx/Dx] **
op is	= for models with inherent safe opt. radiation [op is Gx/Dx] **
op pr	= for models with protected optical radiation [op pr Gx/Dx]. **
mb	= for models with HF barriers. **

\*\* Please observe the markings on the type plate, the model key, as well as the operating instructions for the device. In addition, the following warnings are stated on the identification plate:

<sup>1</sup> See optional/additional marking

**WARNUNG:**  
**NICHT INNERHALB EINES EXPLOSIONSGEFÄHRDETEN BEREICHS ÖFFNEN**  
 Sicherheitshinweise in der Installationsanleitung beachten!

-----  
**WARNING:**  
**DO NOT OPEN IN POTENTIALLY EXPLOSIVE ATMOSPHERES**  
 Observe the safety instructions in the installation guide!

-----  
**ВНИМАНИЕ:**  
**НЕ ОТКРЫВАТЬ в потенциально взрывоопасных средах**  
 Соблюдайте инструкции по технике безопасности в руководстве по установке!

-----  
**AVERTISSEMENT:**  
**NE PAS OUVRIR EN ATMOSPHÈRES EXPLOSIBLES**  
 Respectez les consignes de sécurité dans le guide d'installation!

*Note:*

*If the EPLs or temperature classes of the used secondary ignition protection classes (ix, op is, etc.) are lower than the ones for the primary protection class, the identification of the secondary protection class shall be used, or the effect shall be shown in square brackets. For example: II 2G Ex db op is [op is Ga T4] IIC T6 Gb.*

*Note:*

*IECEx marking is always an integral part of the identification plate. EAC-Ex marking and other affiliated certificates are marked depending on the approval status.*

## 2.1.2 Standards basis and certificate

Basic EX standards:

<b>IEC</b>	<b>EN</b>	<b>DIN EN</b>
IEC 60079-0:2017	EN IEC 60079-0: 2018	DIN EN 60079-0: 2019
IEC 60079-1:2014	EN 60079-1: 2014	DIN EN 60079-1: 2015
IEC 60079-11:2011	EN 60079-11: 2012	DIN EN 60079-11:2012
IEC 60079-18:2014/A1:2017	EN 60079-18: 2015/A1:2017	DIN EN 60079-18:2015/A1:2018-07
IEC 60079-28:2015	EN 60079-28: 2015	DIN EN 60079-28:2016
IEC 60079-31:2013	EN 60079-31: 2014	DIN EN 60079-31: 2014

Named testing laboratory:	TÜV Rheinland (number 0035)
EU type approval certificates:	TÜV 18 ATEX 8218 X (2018)
	TÜV 18 ATEX 8218 X <sup>1st suppl.</sup> (2020)
	TÜV 18 ATEX 8218 X <sup>2nd suppl.</sup> (2021)
	IECEX TUR 18.0023X (2018)
	IECEX TUR 18.0023X <sup>Issue: 01</sup> (2020)
	IECEX TUR 18.0023X <sup>Issue: 02</sup> (2021)
Supplement / Rev. Index:	02

## 2.2 Electrical parameters

### 2.2.1 Voltage supply:

The following electrical limit values are maximum values in the context of the approval. Please observe the device-specific values stated in the respective user manuals!

#### Type T08...:

Input voltage  $U_{IN}$ : 60 V DC / 240 V AC (50/60 Hz)

### 2.2.2 Performance, temperatures and temperature classes

The following tables illustrate the maximum thermal power supplies for all T08 ExCam enclosure types, depending on the ambient temperature and temperature class. The limit values of the electrical power supply were evaluated in the context of the approval, T08 explosion protection concept, and the respective analyses of the housings. These limit values are mandatory.

T08-...	T6 (85°C - 5K)				T5 (100°C - 5K)					
	$T_{AMB}$ [°C]									
	40	50	60	70	40	50	60	70	80	85
	$P_{therm}$ [W]									
VA0.1	10.5	7.9	5.3	2.6	13.4	11.8	9.2	6.6	3.9	2.6
VA0.4	13.8	10.3	6.9	3.4	14.2	12.7	11.2	8.6	5.2	3.4
VA1.1	17.4	13.0	8.7	4.3	23.9	19.6	15.2	10.9	8.5	4.3
VA1.2	18.2	13.6	9.1	4.5	25.0	20.6	15.9	11.4	6.8	4.5
VA2.0	18.2	13.6	9.1	4.5	25.0	20.6	15.9	11.4	6.8	4.5
VA2.1	22.2	16.7	11.1	5.6	30.6	25.0	19.4	13.9	8.3	5.6
VA2.2	25.0	18.8	12.5	6.3	34.4	28.1	21.9	15.6	9.4	6.3
VA2.3	28.6	21.4	14.3	7.1	39.3	32.1	25.0	17.9	10.7	7.1
VA3.x	<i>u.c.</i>	<i>u.c.</i>	<i>u.c.</i>	<i>u.c.</i>	<i>u.c.</i>	<i>u.c.</i>	<i>u.c.</i>	<i>u.c.</i>	<i>u.c.</i>	<i>u.c.</i>
VA4.1K.PS1	55.9	42.9	28.6	14.3	55.9	50.0	44.1	35.7	21.4	14.3

VA4.1K.BORx	57.1	42.9	28.6	14.3	60.0	55.0	50.0	35.7	21.4	14.3
VA4.3.K1.BORx	57.1	42.9	28.6	14.3	78.6	64.3	50.0	35.7	21.4	14.3
VA4.3.K1.PS1	79.2	60.0	40.0	20.0	79.2	70.8	62.5	50.0	30.0	20.0
TNXCD	57.1	42.9	28.6	<i>n.a.</i>	<i>n.a.</i>	<i>n.a.</i>	<i>n.a.</i>	<i>n.a.</i>	<i>n.a.</i>	<i>n.a.</i>

Table 2-1: T08 electrical input supply (T6 and T5)

T08-...	T4 (135°C - 5K)						T3 (200°C - 40K)						
	T <sub>AMB</sub> [°C]												
	50	70	90	100	110	120	50	70	90	110	130	140	150
	P <sub>therm</sub> [W]												
VA0.1	12.0	9.2	6.3	4.9	3.5	2.1	<i>n.a.</i>	<i>n.a.</i>	<i>n.a.</i>	<i>n.a.</i>	<i>n.a.</i>	<i>n.a.</i>	<i>n.a.</i>
VA0.4	12.7	9.7	6.7	5.2	3.7	2.2	<i>n.a.</i>	<i>n.a.</i>	<i>n.a.</i>	<i>n.a.</i>	<i>n.a.</i>	<i>n.a.</i>	<i>n.a.</i>
VA1.1	34.8	26.1	17.4	13.0	8.7	4.3	47.8	39.1	30.4	21.7	13.0	8.7	4.3
VA1.2	36.4	27.3	18.2	13.6	9.1	4.5	50.0	40.9	31.8	22.7	13.6	9.1	4.5
VA2.0	36.4	27.3	18.2	13.6	9.1	4.5	50.0	40.9	31.8	22.7	13.6	9.1	4.5
VA2.1	44.4	33.3	22.2	16.7	11.1	5.6	61.1	50.0	38.9	27.8	16.7	11.1	5.6
VA2.2	50.0	37.5	25.0	16.7	12.5	6.3	68.8	56.3	43.8	31.3	18.8	12.5	6.3
VA2.3	57.1	42.9	28.6	21.4	14.3	7.1	78.6	64.3	50.0	35.7	21.4	14.3	7.1
VA3.x	<i>u.c.</i>	<i>u.c.</i>	<i>u.c.</i>	<i>u.c.</i>	<i>u.c.</i>	<i>u.c.</i>	<i>u.c.</i>	<i>u.c.</i>	<i>u.c.</i>	<i>u.c.</i>	<i>u.c.</i>	<i>u.c.</i>	<i>u.c.</i>
VA4.1K.PS1	47.1	38.2	26.5	20.6	14.7	8.8	<i>n.a.</i>	<i>n.a.</i>	<i>n.a.</i>	<i>n.a.</i>	<i>n.a.</i>	<i>n.a.</i>	<i>n.a.</i>
VA4.1K.BORx	55.0	45.0	35.0	30.0	25.0	14.3	<i>n.a.</i>	<i>n.a.</i>	<i>n.a.</i>	<i>n.a.</i>	<i>n.a.</i>	<i>n.a.</i>	<i>n.a.</i>
VA4.3.K1. BORx	114.3	85.7	57.1	42.9	28.6	14.3	157.1	128.6	100.0	71.4	42.9	28.6	14.3
VA4.3.K1.PS1	70.8	54.2	37.5	29.2	20.8	12.5	<i>n.a.</i>	<i>n.a.</i>	<i>n.a.</i>	<i>n.a.</i>	<i>n.a.</i>	<i>n.a.</i>	<i>n.a.</i>
TNXCD	<i>n.a.</i>	<i>n.a.</i>	<i>n.a.</i>	<i>n.a.</i>	<i>n.a.</i>	<i>n.a.</i>	<i>n.a.</i>	<i>n.a.</i>	<i>n.a.</i>	<i>n.a.</i>	<i>n.a.</i>	<i>n.a.</i>	<i>n.a.</i>

Table 2-2: T08 power supply (T4 and T3)

For the transport/storage temperature and the allowed ambient temperature range, observe the device-specific values stated in the respective user manual!

### 3 General safety instructions and special conditions



**Attention!**

Cameras of the type T08 ExCam are not suitable for use in zones 0 and 20. The ambient temperature, temperature class, and explosion group stated on the enclosure's type plate, must absolutely be observed! The customer is not allowed to make any alterations inside or outside at the camera and must only be used for the intended purpose and in an immaculate condition.



**Attention!**

Only original parts from SAMCON Prozessleittechnik GmbH may be used for repair. Repair works affecting the explosion protection may only be carried out in accordance with the regulations applicable in the country of use and only by SAMCON Prozessleittechnik GmbH.



**Attention!**

Prior to installation, please consider external sources of heat or cold! The permissible temperature range must absolutely be observed!



**Attention!**

If you use the ExCam in the mining sector with a "high" risk of mechanical hazard, you must provide an appropriate device ensuring protection of translucent components (protective grille, etc.)



**Attention!**

Observe the warnings given on the type plate!

**Note:** Depending on the classification of hazard areas, a work approval must be obtained. When adjusting the camera, you shall prevent a potentially explosive atmosphere!



The use in hazardous areas with regard to temperature and dust layers is defined in the respective national regulations.

Prior to the first use, you should test the camera corresponding to the instructions given in the chapter Commissioning.

Please observe the national safety regulations and regulations for prevention of accidents, as well as to the safety instructions given below in this User Manual!

## 4 Area of application

The cameras of the ExCam® series are intended for monitoring plants or processes in hazardous indoor and outdoor areas. When using the camera, adhere to the data specified on its type plates and indicating labels! Applications other than described above are **not** allowed without written permission from Samcon Prozessleittechnik GmbH.



**Attention!**  
 Observed the instructions on the type plates and indicating labels!



**Attention!**  
 If you use the ExCam in the mining sector with a "high" risk of mechanical hazard, you must provide an appropriate device ensuring protection of translucent parts (accessories).



**Attention!**  
 Devices of type T08-VA0.x.K1.GER may not be used in mining/ firedamp hazard (ATEX group 1) or in areas with high risk of mechanical stress (ATEX group 2).



**Attention!**  
 Devices of type T08-VA0.2.K1.GER, T08-VA0.3.K1.GER and T08-VA0.4.K1.GER have a lowest temperature limit of -20°C.



**Attention!**  
 The ExCam with the optical flange VA2.x.Kx.BOR5 (rectangle stepped profile slice) is allowed to be used in the mining industry (ATEX group I) only with a reduced temperature range (-30°C...+135°C)! The ExCam with the model key T08-VA2.x.Kx.BOR5 must also not be used in other hazardous areas with potentially "high" risk of damage caused by mechanical stresses (ATEX group II)!



**Attention!**  
 The ExCam devices with model key T08-TNXCD..., T08-VA4.1K.PS1..., as well as T08-VA4.3.PS1... (optical thermoplastic) must generally not be used for applications in the mining industry (ATEX group I), nor in other hazardous areas with potentially "high" risk of damage caused by mechanical stresses (ATEX group II)!



**Attention!**  
 The ExCam devices with model key T08-TNXCD..., T08-VA4.3.K1.PS1..., as well as T08-VA2.x.Kx.BOR5 may only be used as a stationary device (not hand-held)!

**Attention!**

The ExCam camera of type BCL2x contains inherently safe optical laser radiation of  $\lambda 655\text{nm}$  (op is) with an effect in the hazardous area. The ExCam camera of type BCL2x must not be used in applications in the mining industry (ATEX equipment group I). In IIC gas atmospheres, the temperature classification is limited to T4. Moreover, special laser protection provisions as defined in the latest version of the DIN EN 60825-1 Standard, as well as safety instructions in the device documentation must be observed. Never look directly into the optical path! When doing assembly work, pay attention to the laser beam reflection of reflective surfaces!

All parts of the housing materials, including all external metallic and non-metallic components, are made of high-quality materials to ensure corrosion protection and chemical resistance levels required for the area of application, in "regular" industrial atmospheres and within the specified temperature ranges.

## 5 Packing, transportation and storage

- Pack the cameras securely in the outer carton
- Avoid impacts, mechanical stresses, and vibrations.
- Make sure that neither the package nor the camera is damaged.
- Store the camera in its original packaging and in a dry and weather-proof room, or protect it from dirt and environmental conditions until its final assembly and installation.
- Avoid extreme heat or cold sources.
- Maximum storage time: 3 years; after this period, the condition of the camera has to be checked.

## 6 Commissioning

### 6.1 Installation

For the camera's installation and operation, the relevant national regulations, as well as the generally accepted rules of technology shall prevail. Before mounting the camera, thoroughly check it for any transport damage, especially at the housing and cable. Installation, electrical connection and the first commissioning must only be carried out by qualified personnel.



**Attention!**

**Prior to the camera installation, take external sources of heat or cold into account! Observe the permissible temperature range!**



**Attention!**

**Observe the national safety, installation and accident prevention regulations (e.g. DIN EN 60079-14) and the safety instructions in the corresponding operating instructions and in this EX installation instruction!**



**Attention!**

**If you use the ExCam in the mining sector with a “high” risk of mechanical hazard, you must provide an appropriate device ensuring protection of translucent parts (accessories)**

#### 6.1.1 Types from T08-VA0.1 to VA2.2

For monitoring of plants and/or persons, the camera can be mounted on swivelling mounts (accessories). For this purpose, the mounting pin, welded to the bottom of the camera body dispose of holes with either 6.5 mm or 8.5 mm. The wall bracket is available in different sizes and can be mounted in any position via four holes (see Figure 6-1 *left*).

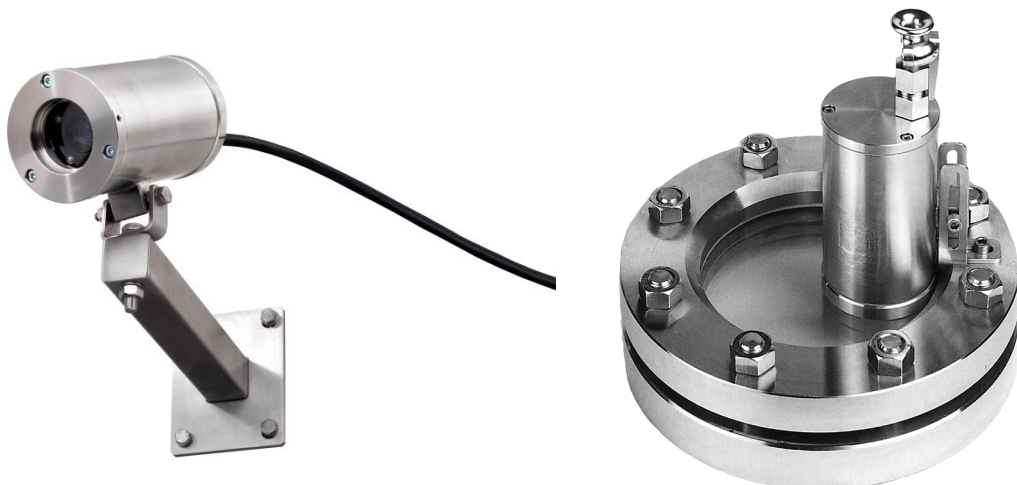

Fig. 6-1: T08-VA1.1 to VA2.2. Mounting options

For process monitoring, the camera can be mounted by means of a hinge attachment suitable for every application (e.g. on sight glass fittings in accordance with DIN 28120/28121 or DIN 11851), see Figure 6-1 *right*.

Details and availability of accessories are described in the User Manual for the applicable T08 device.

### 6.1.2 Type T08-VA2.3

Due to the dimensions and the weight of the ExCam camera with the model key T08-VA2.3, a "safety wire" is mandatory in order to protect the device from falling down. The illustration below shows the recommended method of the safety wire installation. Use the welded mounting pin at the housing, as well as the special wall bracket "WMB VA2.3" or "WMB EXCAM XF" and the pole adapter PMB-VA2.x or "PMB EXCAM XF".

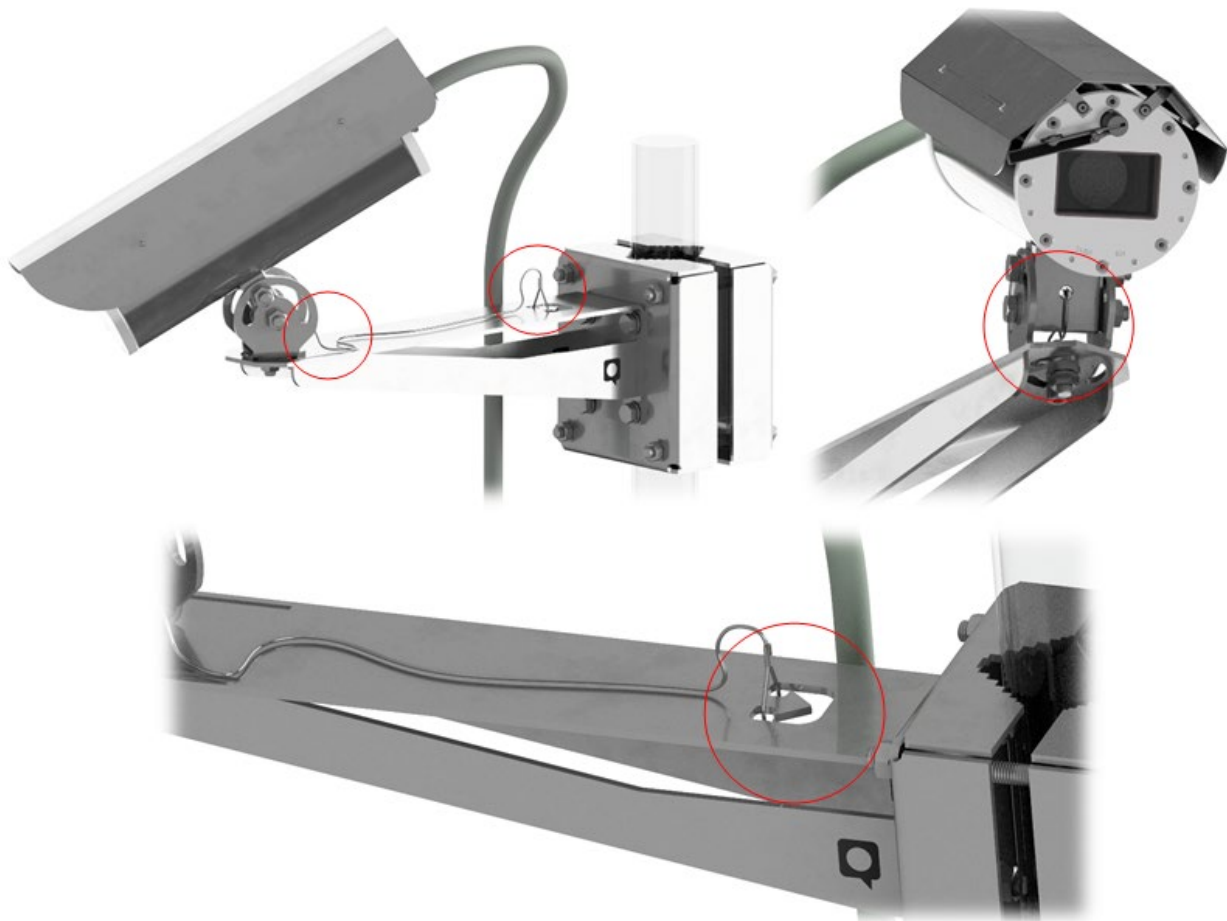

Fig. 6-2: T08-VA2.3 Safety wire

For detailed assembly instructions on installation components and accessories, please visit <http://samcon.eu>

### 6.1.3 Type T08-VA4.x

The PTZ camera Type T08-VA4.1K.PS1 is installed in a hanging position or vertically. Due to the dimensions and the weight of the ExCam camera with the model key T08-VA4.XXX, a "safety wire" is mandatory in order to protect the device from falling down. The bonding wire shall be secured closer to the camera to prevent twisting.

### 6.1.4 Type T08-TNXCD

The PTZ camera of type T08-TNXCD is installed in a hanging position (translucent dome, facing downwards). For this, the dome camera can be mounted on a wall through the six M8x1.25 threaded holes in the lid flange and wall bracket with L-profile (accessories), or on a ceiling through eyebolts and chain links. In addition, the camera housing has to be secured with the "**safety wire**" for heavy load falling protections, included in the delivery scope.

## 6.2 Opening and closing the housing

### 6.2.1 Type T08-VAx.x.x.x



**Attention! The pressure-resistant type T08-VAx.x.x.x may only be opened if it is explicitly indicated in the User Manual of the respective camera, for example, in order to manually adjust the varifocal lenses, to remove or to replace the SD memory card, or to renew the gasket as required in the maintenance schedule, etc.**



**Attention! Observe the warnings on the type plate.**  
**Note: Depending on the classification of hazard areas, a work approval must be obtained. When adjusting the camera, you shall prevent potentially explosive atmosphere!**

The T08 ExCam series camera may only be opened due to functional aspects and only if it is explicitly allowed in the respective user manual. In all other cases, the explosion-proof housing may only be opened and closed by authorized staff of SAMCON Prozessleittechnik GmbH. Any damages, irregularities, or changes which, through the borosilicate sight glass, are visible inside the ExCam, for example, loosened or not tightened components, discolouration, or liquid inclusions (not to be confused with condensed water!), have to be checked by the manufacturer, SAMCON Prozessleittechnik GmbH.

Please absolutely observe the following points:

Before opening the housing of the T08-VAx.x.x.x camera, it may be necessary to remove the weather protection roof or other external accessories.

- Remove or loosen the bolted connections of the camera housing flange and body.
- Use only appropriate tools and pay attention to the respective spring rings (DIN 127A).
- Caution: Avoid any contact of the screw thread with skin and/or clothes! The screw threads are covered with LOCTITE® 243™ (chemical basis is dimethacrylate ester). This is to prevent the bolted connection from unintentional loosening because of impacts and vibrations and for sealing purposes.

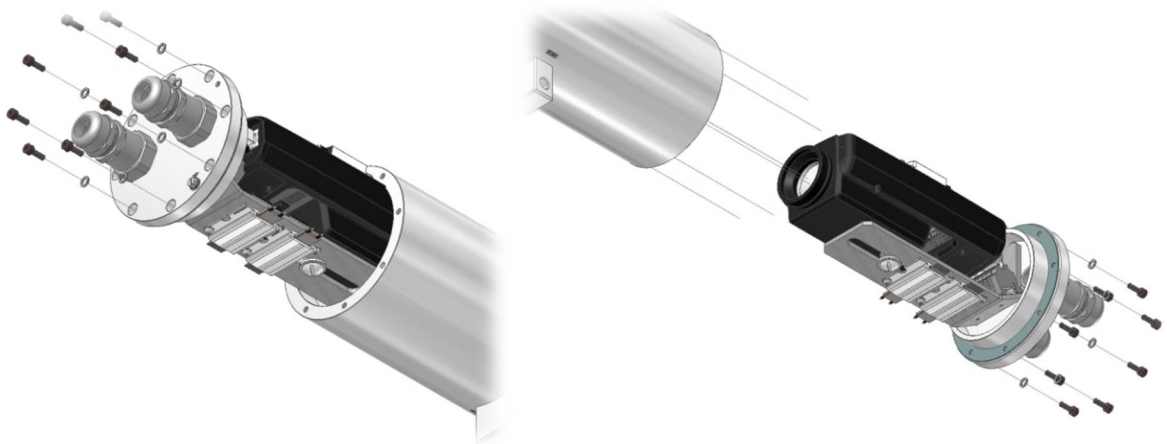

Fig. 6-3: Opening the ExCam T08-VAx.x.x.x camera

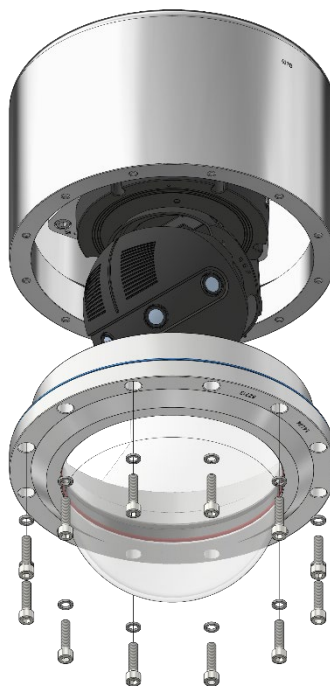

Fig. 6-4: Exception ExCam T08-VA4.1K.PS1

- Carefully pull out the cable and supply flange to the rear and strictly vertically/perpendicularly (see Figure 6-4). There is a risk of side tilt! Because of negative pressure it may be difficult to remove the flange.  
Exception: There is no cable and supply flange for models of the ExCam series T08-VA4.1K.PS1. For this models pull out the optical flange (see Fig. 6-4).
- The circular cylindrical clearance fit H8f7 or H8G7 (in accordance with ISO 286) of the camera body and flange must not be tilted! **Risk of damage to the flame-proof gap (DIN EN 60079-1)!**
- Caution: Avoid any contact of the screw thread with skin and/or clothes! There is oil lubricating paste applied, to protect the surface against fretting corrosion and mechanical stresses.
- Attention: Use particular care when dealing with installed components (camera module, optics, temperature control, electronics, etc.) which are fixated above the mounting adapter on the cable and supply flange (cable gland). Risk of damage!
- Attention: When removing the flange, ensure that the Gylon flat gasket (Style 3504, blue) does not get damaged or dirty!
- After the completion of the work at the components which are installed inside the camera, immediately re-close the housing. Ensure that no foreign objects and particles are enclosed in the housing!
- For closing the housing, follow the instructions for opening the housing in reversed order. Please observe the following safety warnings:



**Attention!**

**Insert the flange to reach the end position, in order to ensure ignition protection and the protection level (IP) of the housing.**



**Attention!**

**If the bolted connections are tightened too strongly, it can cause damages to the device!**



**Attention!**

**Do not to damage the surface of the drill hole and the shaft (fitting) of the flame-proof gap.**



**Attention!**

**Ensure that you do not damage the housing seals. Keep them clean.**



**Attention!**

**If the fitting gap is mechanically damaged, it is no longer allowed to use the housing!**



**Attention!**

**Ensure that no foreign objects are entrapped in the housing.**

- Exclusively use undamaged and clean **original screws** included in the supply. The dismantled screw locks (spring washers DIN 127A) must be used again.
- The Gylon gasket must be used in undamaged condition, according to the flange hole pattern. The surface orientation is arbitrary.
- If, when closing the housing, you notice that the surface of the fitting gap is dirty or insufficiently lubricated, clean it with a clean cloth and suitable cleaning agent (e.g. concentrated isopropyl alcohol) and then grease it with lubricant which is suitable for this specific application.
- The **M3 screwed connections** of **VA0.x** flange and body components must be tightened with a torque of **1.2 Nm** (crosswise)!  
The **M4 screwed connections** of the **VA1.x** and the **V2.x** flange and body components require a torque of **3.0 Nm** (*tighten crosswise!*)  
The **M6 screwed connections** of the **VA4.x** flange and body components must always be tightened *crosswise* with a torque of **9.0 Nm**!  
Do not tighten the screws too strongly! It can cause rupture of the cylinder head and thus lead to an impairment of the pressure resistance or ignition protection class of the camera housing.

### 6.2.2 Type T08-TNXCD



**Attention! The pressure-resistant dome housing of the type T08-TNXCD may only be opened if it is explicitly written in the user manual of the respective camera or in the case of manual adjustment, removal or changing the SDHC memory card, change of O-ring seals, hardware reset, etc.**



**Attention! Observe the warnings given on the type plate:**

**Note: Depending on the classification of hazard areas, a work approval must be obtained. When adjusting the camera, you must prevent potentially explosive atmosphere!**

The T08 ExCam series camera of the type TNXCD may only be opened due to functional aspects and only if it is explicitly allowed in the respective user manual. In all other cases, the explosion-proof housing may only be opened and closed by authorized staff of SAMCON Prozessleittechnik GmbH. Any damages, irregularities, or changes which, through the translucent polycarbonate dome cupola, are visible inside the ExCam, for example, loosened or not completely tightened components, discolouration, or liquid inclusions (not to be confused with condensed water!), have to be checked by the manufacturer, SAMCON Prozessleittechnik GmbH.

Furthermore, please observe the following instructions:

- Before opening the housing of the T08-TNXCD camera, you should remove the external accessories, etc.
- To open the housing in an appropriate work surrounding, first detach it from the wall bracket.  
 Attention: Carry the connecting cables along and ensure that they are not damaged or bent (observe the specified bending radius), or disconnect them from the Ex e terminal box or Ex e/Ex d plug-and-socket device, etc.!
- The housing may only be opened via the cable and supply flange. Never open the optical lens flange!
- To open the housing, fix the body first. The cover flange with cable pigtail should remain movable (use e.g. clamps or pads on a workbench edge).
- At first, unscrew the stainless steel countersunk screw with internal hexagon (DIN 7991) on the flange component (see Fig. 6-5)

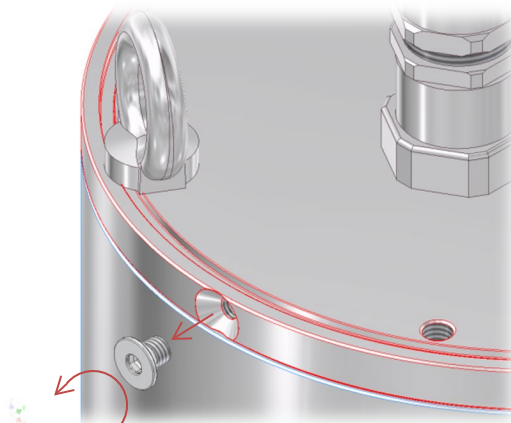

Fig. 6-5: Removing the countersunk screw, type T08-TNXCD

- Unscrew the cover flange with fine thread (M188X1.5) counter-clockwise (*ISO metric screw profile, right-turning*). It is recommended to provide the outer M8x1.25

threaded holes with screws, ring eyelets, etc., in order to facilitate the screw driving.  
Attention: It may be necessary to lay and also rotate cable tails!

- Attention: Pull out very carefully and strictly vertically/perpendicularly the cover flange with the multi-storey adapter, electronics printed circuit boards, PTZ module, etc.

**Danger of side tilting and damaging of the internal components!**

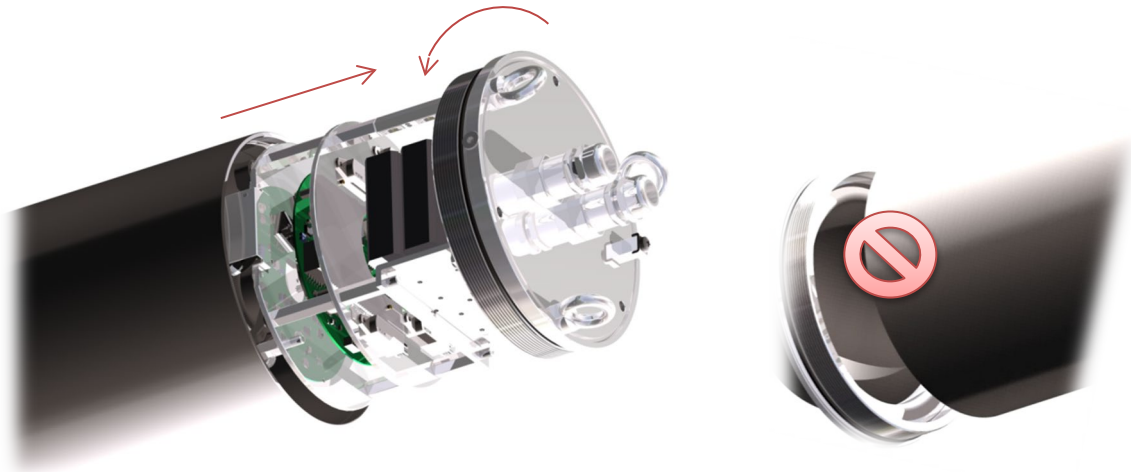

Fig. 6-6: Opening the cover flange of type T08-TNXCD

- Ensure that the metric fine thread on the flange and camera body component is not damaged! **Risk of damage to the flame-proof threaded gap (DIN EN 60079-1)!**
- Caution: Do not touch the screw threads with your skin or clothes! There is oil lubricating paste to protect the surface against fretting corrosion and mechanical stresses.
- Attention: Use particular care when dealing with installed components (camera module, temperature control, swivelling/tilting drives, adapters, mechanics, etc.) fixed above the mounting adapter on the cable and supply flange gland).  
Risk of damage to the device and drifting of the optical axis!
- Attention: When removing the flange, ensure that the black O-ring seal in the groove does not get damaged or dirty!

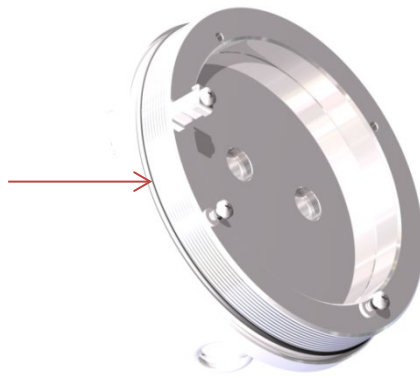

Fig. 6-7: Position of the O-ring seal, type T08-TNXCD

- After the completion of the work at the components installed in the camera, immediately re-close the housing. Ensure that no foreign bodies and particles are entrapped in the housing!
- For closing the housing, proceed in reverse order as when opening. Please adhere to the following safety warnings:



**Attention!**

**Screw the cover flange up to the end position, in order to ensure ignition protection and the protective level (IP) of the housing.**



**Attention!**

**Tighten the flange by hand (no tightening torque is specified for this purpose).**



**Attention!**

**Ensure that you do not damage the thread surface of the flame-proof gap.**



**Attention!**

**Make sure that the O-ring seal of the housing is perfectly placed in its groove, not damaged and not contaminated.**



**Attention!**

**If the thread surface is damaged, the housing must not be longer used!**



**Attention!**

**Ensure that no foreign objects get entrapped in the housing.**



**The countersunk screw with internal hexagon (DIN 7991) on the flange component must absolutely be re-tightened (approximately 2.5 Nm tightening torque is required).**

### 6.3 Electrical connection and commissioning



**Attention!**

The electrical connection of the equipment must only be carried out by officially qualified and skilled personnel!



**Attention!**

It is absolutely necessary to ground the ExCam® series housing via the PA connection (4mm solid/rigid conductor)



**Attention!**

As far as possible, the first commissioning of the device should be carried out at positive temperatures, in order to prevent condensation in the housing.



**Attention!**

Model variants equipped with “flipConnect” (\_000.X-X\_) are always delivered as cableless devices. The pre-assembled red M25 blanking plug (nylon) is not explosion-proof and is only used as an assembly tool for connecting the flipConnect! The installation of suitable explosion-proof connection cable kits to the ExCam device is the responsibility of the user, or can be found in the SAMCON compatibility table:

<https://www.samcon.eu/fileadmin/documents/de/60-Montage%26Installation/flipConnect-Compatibility.pdf>

If the customer uses third-party manufacturer Ex d cable and glands the temperature ranges must be observed. In this case, both components must be certified for the maximum ambient temperature, as well as the maximum resulting interior temperature of the ExCam. These values are individual for each device and can be found in the respective operating instructions and on the type plate!

Prior to commissioning, all tests must be carried out, as indicated by the national regulations. Furthermore, the correct function and installation of the device must be checked in accordance with this user manual and other applicable regulations.

Incorrect installation and operation of the camera may lead to a loss of warranty!

**The functional “Commissioning” of each device is described in the respective user manual.**

#### **6.4 Additional elements (appropriate cables and cable glands)**

For information on components that complete the equipment, such as appropriate cables and cable glands, refer to the relevant user manual.

## 7 Problems, hints, solutions

Problem with	Hint	Troubleshooting
Mounting	Do not drill holes in the housing	Visual inspection
	Mount the camera to the mounting pin only	Visual inspection
	Do not attach any components not approved by SAMCON to the housing	Visual inspection
Transportation, Operation	Damage to housing, seal, cable gland	Replacement of damaged parts, regular maintenance
Operation	Use of unsuitable cable glands and plugs	must be certified
	Wrong temperature range	Observe the type plate and safety instructions in the Ex installation instructions; specified temperature ranges must not be exceeded or fallen below.
	WrongEx zone /Ex-grorup	Observe the type plate and safety instructions in the Ex installation manual
Open the housing	only if expressly permitted in the operating instructions	Do not open inside the potentially explosive area
Close the housing	foreign bodies included	Visual inspection, remove immediately
Incorrect opening or closing of the enclosure	Only if expressly permitted in the camera's operating instructions	Only use original screws; Adhere to the specified torques of the screw connections; Check the surface of the mating flange and body, fine threads for cable and line entries for damage and contamination.
Scratches at the plastic dome	Observe the instructions in the operating instructions for cleaning; only use scratch-free, damp cloths and no aggressive media for cleaning; avoid static charge	Visual inspection; Change
Potential equalization; Grounding resistance too high	Wire the marked terminal points using cable lugs/eyelets in accordance with national earthing regulations (recommended $\varnothing_{min}=4mm^2$ solid conductor/rigid)	Check

Observe all safety instructions of this Ex-installation instruction, do not damage the housing. Adhere to the specified temperature ranges. Pay attention to the potential equalization. Avoid static electricity, also when cleaning. The installation position of the dome cameras is hanging. Do not mount anything at the flanges. Do not work on or paint the housing surfaces. Pay attention to regular maintenance.

If you have a technical problem, please contact our support.

## 8 Maintenance/ Modification

The applicable regulations for the maintenance and servicing of electrical devices in potentially explosive atmospheres must be observed. The necessary maintenance intervals depend on the operating condition and should be individually determined by the user. The maintenance tasks especially include examination of parts on which the ignition protection depends (e.g., proper condition of the housing, seals and cable entry points). A visual inspection of the protective housing must be carried out every 3 years.

All necessary maintenance measures should be initiated and/or executed.

The normal service life of the device/electronics is approximately 7 years, the normal service life of the protective housing is 15 years. After 15 years at the latest, the flameproof gap should be checked in detail and all plastic parts that are relevant to explosion safety should be replaced. In the case of increased UV exposure, a detailed inspection of the housing is recommended after 10 years.

## 9 Repair

Repair must only be carried out with original spare parts of SAMCON Prozessleittechnik GmbH. Damaged pressure-resistant housings must be replaced completely. If in doubt, return the component(s) to SAMCON Prozessleittechnik GmbH.

Repair affecting the explosion protection must only be carried out in accordance with nationally applied regulations by SAMCON Prozessleittechnik GmbH or by an authorised electrical technician authorised by SAMCON Prozessleittechnik GmbH. Rebuilding of or alterations to the devices are not permitted.

## 10 Disposal/ Recycling

When disposing of the device, observe the regulations applicable in your country.

## 11 Drawings

Drawings of the devices can be taken from the data sheets. DXF, DWG drawing files with the relevant dimensions, as well as 3D models (.pdf, .step, IGES, etc.), including the ones of all accessories are available at [www.samcon.eu](http://www.samcon.eu). If you require additional technical information, please contact us at [support@samcon.eu](mailto:support@samcon.eu).

## 12 Certificates

### 12.1 EU - Declaration of Conformity

# EU - Konformitätserklärung

*EU – Declaration of Conformity / UE – Déclaration de Conformité*

Der Hersteller / *The manufacturer / Le fabricant*



**Schillerstraße 17**  
**35102 Lohra-Altenvers**

erklärt in alleiniger Verantwortung, dass sein Produkt / *declares under his sole responsibility, that his product / déclare sous sa seule responsabilité, que son produit*

## ExCam® T08...

gekennzeichnet mit / *marked with / marqué avec*

⊕ II 2G Ex db IIC T6 Gb\*  
 ⊕ II 2D Ex tb IIIC T80°C Db\*

⊕ I M2 Ex db I Mb\*  
 \*Optional/Additional marking:  
 see user manual and type plate

bescheinigt mit EU-Baumusterprüfbescheinigung / *certified by EU type examination certificate / ayant fait l'objet de l'attestation UE de type*

### TÜV 18 ATEX 8218 X<sup>1</sup>

auf das sich diese Erklärung bezieht, mit der/den folgenden Richtlinien, Normen oder normativen Dokumenten übereinstimmt:  
*referred to by this declaration is in conformity with the following directives, standards or normative documents:*  
*auquel se rapporte la présente déclaration, est conforme aux directives, normes ou aux documents normatifs suivants:*

Richtlinien/ Directives/Directives	
ATEX	2014/34/EU / 2014/34/EU / 2014/34/UE
ROHS	2011/65/EU / 2011/65/EU / 2011/65/UE
LVD	2014/35/EU / 2014/35/EU / 2014/35/UE
EMC	2014/30/EU / 2014/30/EU / 2014/30/UE

Normen / Standards / Normes	
EN IEC 60079-0:	2018
EN 60079-1:	2014
EN 60079-11:	2012
EN 60079-14:	2014
EN 60079-18:	2015 /A1:2017
EN 60079-28:	2015
EN 60079-31:	2014



Digital unterschrieben von Dipl.-Ing.  
 Steffen Seibert  
 DN: cn=Dipl.-Ing. Steffen Seibert,  
 o=SAMCON Prozessleittechnik  
 GmbH, ou=CEO,  
 email=s.seibert@samcon.eu, c=DE  
 Datum: 2025.08.06 11:43:46 +02'00'

Dipl.-Ing. Steffen Seibert  
 Geschäftsführer

Altenvers, den / *the / le* 06.08.2025

<sup>1</sup> benannte Stelle / organisme notifié / notified body: TÜV Rheinland Zertifizierungsstelle für Explosionsschutz of TÜV Rheinland Industrie Service GmbH (0035)

## 12.2 UKCA - Declaration of Conformity

# UKCA – Declaration of Conformity

The manufacturer



declares under his sole responsibility, that his product,

## ExCam® T08...

marked with

⊕ II 2G Ex db IIC T6 Gb\*  
⊕ II 2D Ex tb IIIC T80°C Db\*

⊕ I M2 Ex db I Mb\*  
*\*Optional/Additional marking;  
see user manual and type plate*

and

# UK CA

fulfils the fundamental safety and protection requirements standards in accordance with the guidelines and harmonized standards listed below. This declaration of conformity refers to the design and manufacture of the above products.

### Directives

UK: Regulation SI 2016 No. 1107  
"Protective Systems Intended for Use in Potentially Explosive Atmospheres"

### Standards

EN IEC 60079-0:	2018
EN 60079-1:	2014
EN 60079-11:	2012
EN 60079-14:	2014
EN 60079-18:	2015 /A1:2017
EN 60079-28:	2015
EN 60079-31:	2014



Digital unterschrieben von Steffen Seibert  
DN: cn=Steffen Seibert, o=SAMCON Prozessleittechnik GmbH, ou, email=s.seibert@samcon.eu, c=DE  
Datum: 2024.04.30 08:53:07 +02'00'

Dipl.-Ing. Steffen Seibert  
Managing Director

SAMCON Prozessleittechnik GmbH  
Schillerstraße 17  
D-35102 Lohra-Altensers  
[www.samcon.eu](http://www.samcon.eu)  
T: +49 6426-9231 0 / F: +49 6426-9231 31

Altensers, den / the / le 30.04.2024

Doc. - Id.: 240430-PT08BAUUKCA-SS-Declaration of Conformity.docx

### **12.3 EU Type Examination Certificate (ATEX)**

see <http://samcon.eu>

### **12.4 IECEx Certificate of Conformity:**

see <http://samcon.eu>

### **12.5 EAC-Ex Certificate**

see <http://samcon.eu>

### **12.6 Other certificates**

see <http://samcon.eu>

## 13 Notes



**SAMCON**

Schillerstraße 17, 35102 Lohra-Altenvers  
[www.samcon.eu](http://www.samcon.eu), [info@samcon.eu](mailto:info@samcon.eu)  
fon: +49 6426 9231-0, fax: - 31