



Selection guide Safety barriers

Series 9001/9002/9004

Table of contents

1	General Information	3
1.1	Manufacturer.....	3
1.2	Further documents.....	3
2	Quick selection.....	4
3	Introduction to safety barriers.....	6
3.1	What are safety barriers?.....	6
3.2	Application	7
3.3	Function	8
3.4	Equipotential bonding/grounding.....	8
4	Mechanics.....	10
4.1	Mounting and grounding	10
4.2	Interchangeable back-up fuse.....	11
4.3	Dimensions/fastening dimensions.....	12
5	Selecting safety barriers.....	13
5.1	Function – barrier type	13
5.2	Function – electrical values.....	16
5.3	Safety – Ex i values.....	17
5.4	Safety – connection.....	17
6	Example applications	23
7	Appendix.....	46
7.1	Accessories and spare parts.....	46

1 General Information

1.1 Manufacturer

R. STAHL Schaltgeräte GmbH
Am Bahnhof 30
74638 Waldenburg
Germany





Phone: +49 7942 943-0
Fax: +49 7942 943-4333
Internet: r-stahl.com
E-mail: info@r-stahl.com

1.2 Further documents







- Data sheet 900x
- Operating instructions 900x

For documents in other languages, see r-stahl.com.

2 Quick selection

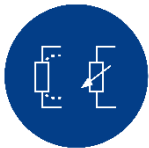
Symbol	Application	Recommended safety barrier	Link to example
2-wire transmitters 	Regulated power supply Precision resistor in the supply line Grounded field circuit	9001/01-280-110-101	⇒ Example
	Regulated power supply Precision resistor in the return line Ungrounded field circuit	9002/13-280-110-001	⇒ Example
	Unregulated power supply Precision resistor in the return line Grounded field circuit	9001/51-280-110-141	⇒ Example
3-wire transmitters 	Regulated power supply Grounded field circuit	9002/13-280-110-001	⇒ Example
I/P converters, control valves, indicators 	Regulated power supply Regulation in the supply line Grounded field circuit	9001/01-280-110-101	⇒ Example
	Regulated power supply Regulation in the return line Ungrounded field circuit	9002/13-280-110-001	⇒ Example
Solenoid valves, LED indicator lamps, audible alarm indicators 	Regulated power supply Regulation in the supply line Grounded field circuit	9001/01-280-110-101	⇒ Example
	Regulated power supply Regulation in the return line Ungrounded field circuit	9002/13-280-110-001	⇒ Example
	Unregulated power supply Regulation in the supply line Grounded field circuit	9001/01-252-100-141	⇒ Example
	Unregulated power supply Regulation in the return line Ungrounded field circuit	9002/13-252-121-041	⇒ Example
	Multiple field devices Regulated power supply Regulation in the supply line Grounded field circuit	9002/11-280-186-001	⇒ Example

Quick selection

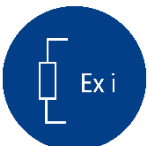
Symbol	Application	Recommended safety barrier	Link to example
Initiators, proximity switches 	3-wire PNP Regulated power supply Grounded field circuit	9002/13-280-110-001	⇒ Example
	3-wire NPN Regulated power supply Grounded field circuit	9002/11-280-186-001	⇒ Example
Thermocouples, mV signals 	Ungrounded field circuit	9002/77-093-300-001	⇒ Example
Resistance thermometers, resistance remote transmitters 	Pt100, 2-wire circuit, ungrounded field circuit	9002/22-032-300-111	⇒ Example
	Pt100, 3-wire circuit, ungrounded field circuit	9002/22-032-300-111 + 9001/02-016-150-111	⇒ Example
	Pt100, 4-wire circuit, ungrounded field circuit	9002/22-032-300-111 + 9002/77-093-040-001	⇒ Example
Binary inputs, potential-free contacts, optocoupler outputs 	Regulated power supply Switch (load in the supply line) Grounded field circuit	9001/01-280-110-101	⇒ Example
	Regulated power supply Switch (load in the return line) Ungrounded field circuit	9002/13-280-093-001	⇒ Example
	Unregulated power supply Switch (load in the return line) Grounded field circuit	9001/01-252-060-141	⇒ Example
Load cells (strain gauge) 	350 Ω 6 wires + 10 V Ungrounded field circuit	9002/11-130-360-001 + 9002/11-120-024-001 + 9002/11-120-024-001	⇒ Example
	350 Ω or 700 Ω 6 wires + 16 V Ungrounded field circuit	9002/13-199-225-001 + 9002/11-199-030-001 + 9002/11-199-030-001	⇒ Example
Fire and gas detectors 		9001/01-280-165-101	
Safety barriers with electronic current limiting 	Series 9004 safety barriers can replace Series 9001 safety barriers in applications Advantages: <ul style="list-style-type: none"> Lower series resistance and therefore better power output Drawbacks: <ul style="list-style-type: none"> Worse safety characteristic values Only for ib electrical circuits 	9004	

3 Introduction to safety barriers

3.1 What are safety barriers?

Safety barriers (also known as Zener barriers) are used to connect intrinsically safe circuits (Ex i) and non-intrinsically safe circuits, such as Ex i field devices with automation systems. They can process standard signals such as 4 to 20 mA, as well as less common ones. There are many safety barriers which have been specifically developed for certain applications.

The barriers use a combination of Zener diodes, resistors and fuses to limit the electrical energy that enters the hazardous area with reference to their ground connection. Safety barriers are characterised by a very extensive application area.

R. STAHL offers three different series of safety barriers:

Single-channel safety barriers Series 9001

Hazardous area

Safe area

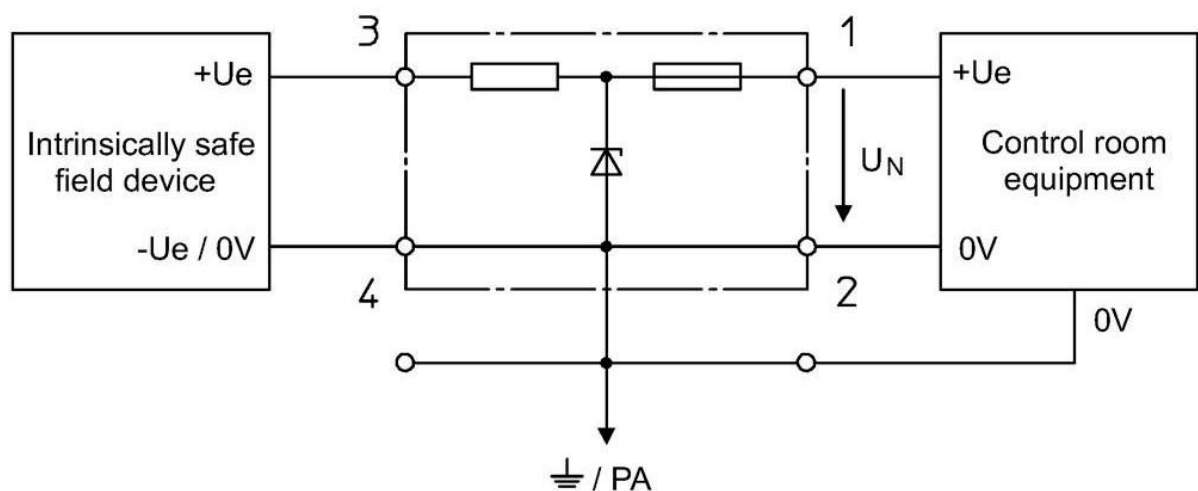

05438E02

Two-channel safety barriers Series 9002

Hazardous area

Safe area

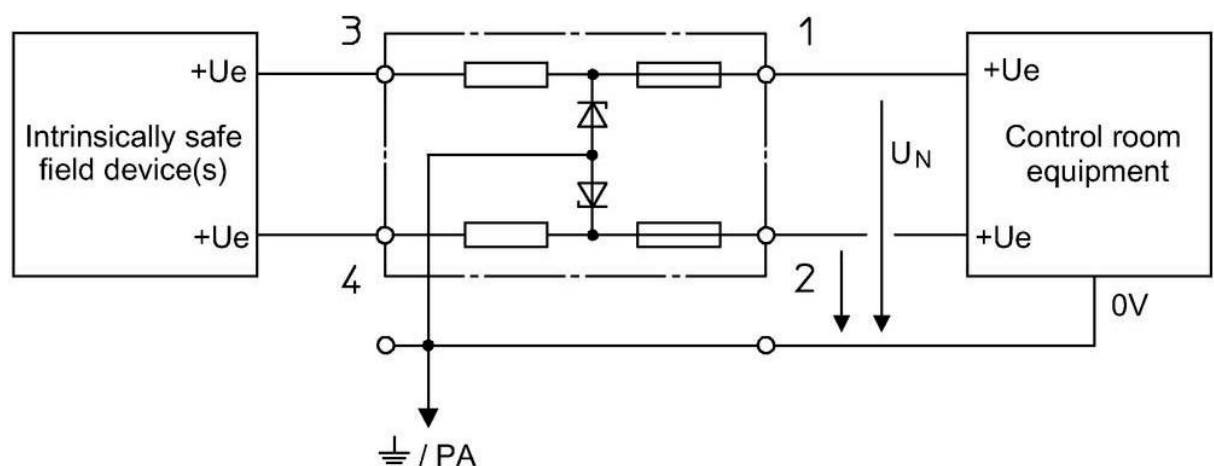

05820E02

Safety barriers with electronic current limiting Series 9004

Hazardous area

Safe area

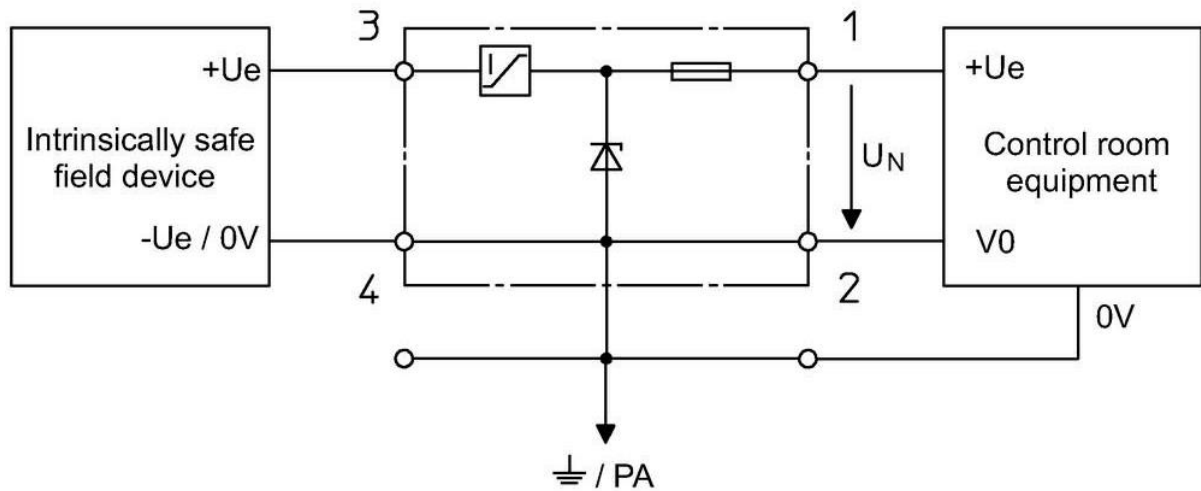

05853E02

3.2 Application

Safety barriers are used as cost-effective isolators without galvanic separation between intrinsically safe and non-intrinsically safe circuits. Their function is to protect electrical circuits (i.e. cables and apparatus) that are installed in hazardous areas.

Safety barriers are considered associated apparatus.

An intrinsically safe circuit always consists of intrinsically safe apparatus (field device) and associated apparatus (safety barrier, isolator, remote I/O, etc.). As associated apparatus, safety barriers form the bridge between the intrinsically safe circuit and the non-intrinsically safe circuit. Depending on the application, it may be necessary to use multiple devices in a single connection (see section 5.4).

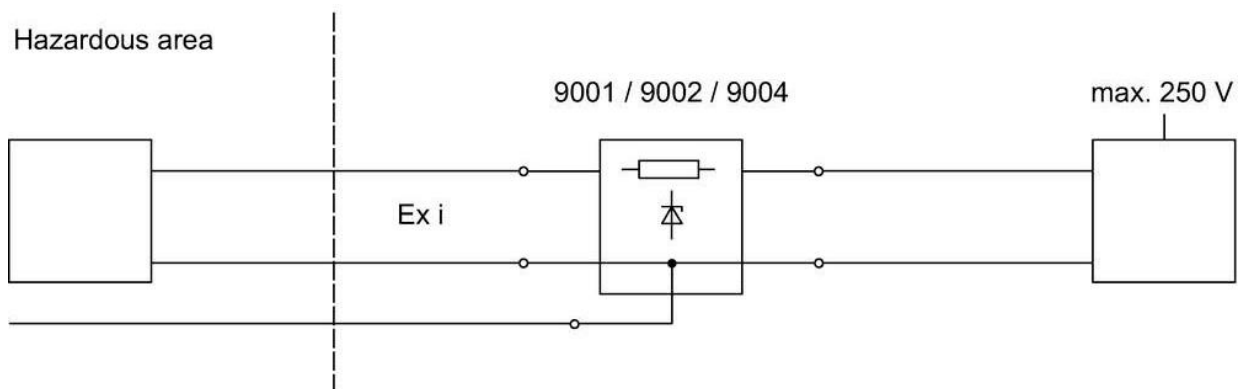

09911E_02

Since safety barriers also contain non-intrinsically safe circuits, they either have to be installed outside the hazardous area or, if suitably certified, in Zone 2/Division 2. All safety barriers from R. STAHL are suitable for installation in Zone 2/Division 2.

The use of another type of protection (e.g. flameproof enclosure) makes it possible to install the safety barriers in Zone 1.

3.3 Function

The function of safety barriers is to limit the power fed into an intrinsically safe circuit so that ignition is prevented, whether due to sparks or thermal effects (hot surfaces). A safety barrier has three main elements for this purpose:

- Zener diode to limit voltage
- Resistor or semiconductor component to limit current
- Fuse to protect the Zener diode

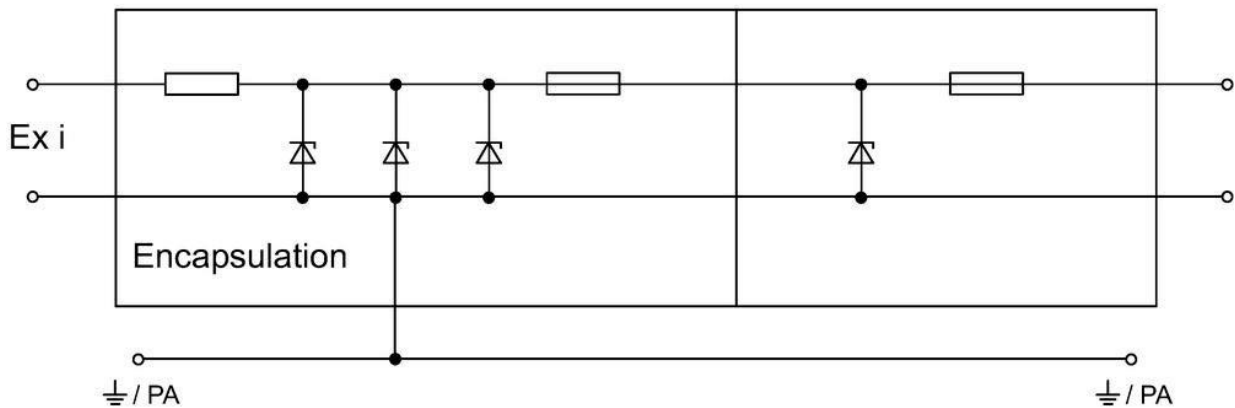

09912E_02

R. STAHL Series 9001, 9002 and 9004 safety barriers also contain a protective circuit with an interchangeable back-up fuse which is accessible from the outside and protects the inaccessible internally encapsulated fuse of the safety barrier. The protective circuit prevents both fuses tripping at the same time.

To cover the entire range of automation technology applications, some safety barriers contain function blocks like electronic current limiting, amplification, etc.

3.4 Equipotential bonding/grounding

Potential differences may render intrinsic safety and therefore explosion protection ineffective, as safety barriers do not have galvanic separation between the input and output. All (national) standards for setting up intrinsically safe circuits therefore stipulate that:

- Equipotential bonding or a grounding system must be present and
- Safety barriers must be connected to this equipotential bonding

Safety barriers from R. STAHL can alternatively be connected to the equipotential bonding either directly via the electrically conductive snap-on mechanics or using the \perp /PA/equipotential bonding terminal.

For electrical or measurement reasons, an ungrounded circuit may be necessary.

An ungrounded circuit can in general be created by using a two-channel safety barrier or by connecting two single-channel safety barriers.

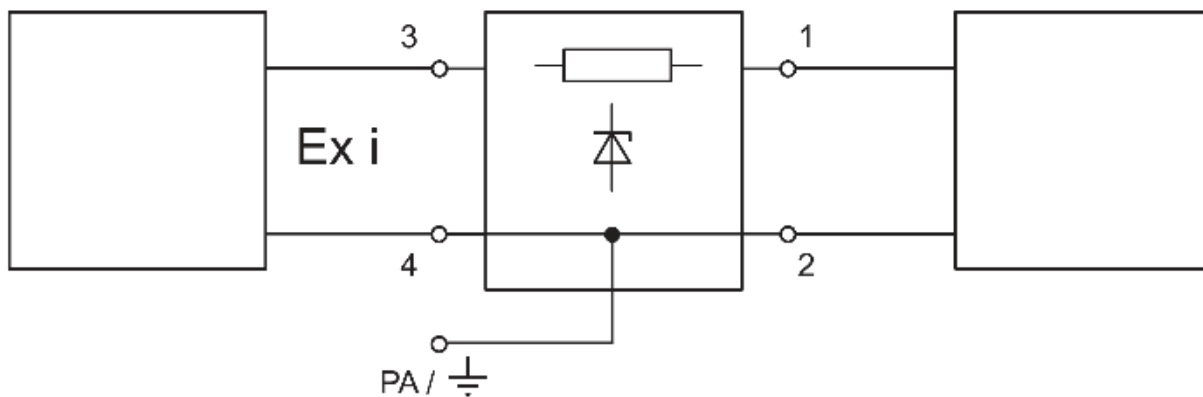

09935E

Grounded electrical circuit

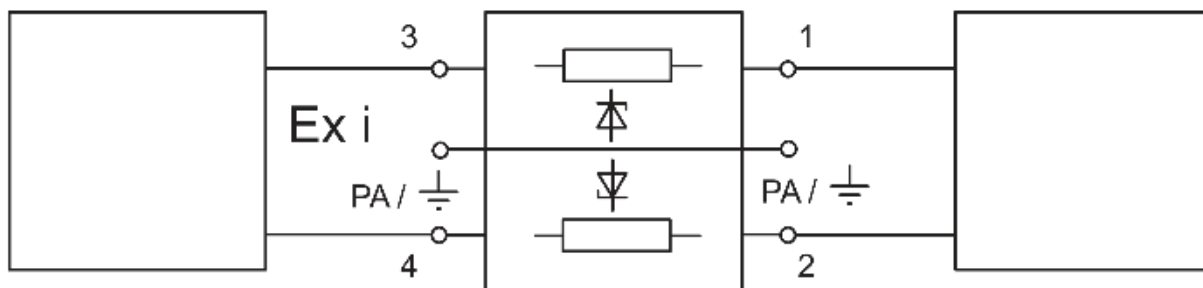

09936E

Ungrounded electrical circuit

Even if the circuit is "ungrounded" or the safety barrier has been designed to be isolated from the DIN rail using the clamping bases available as accessories, safety barriers must always be connected to \perp /equipotential bonding.

It must also be ensured that the connection to \perp /equipotential bonding is less than 1 Ω . National regulations may have stricter requirements.

4 Mechanics

4.1 Mounting and grounding

R. STAHL Series 9001, 9002 and 9004 safety barriers are set apart by their exceptional ease of installation. They are snapped directly on to a 35 mm DIN rail (NS 35/15) without a mounting attachment.

At the same time, this creates a conductive connection between the \perp /equipotential bonding connection of the safety barrier and the rail. Multiple safety barriers are grounded by connecting the rail to the actual equipotential bonding/grounding system (collective grounding).

Alternatively, it is also possible to ground the safety barriers individually. The \perp /equipotential bonding terminal is provided on the intrinsically safe connection side of the safety barrier for this purpose.

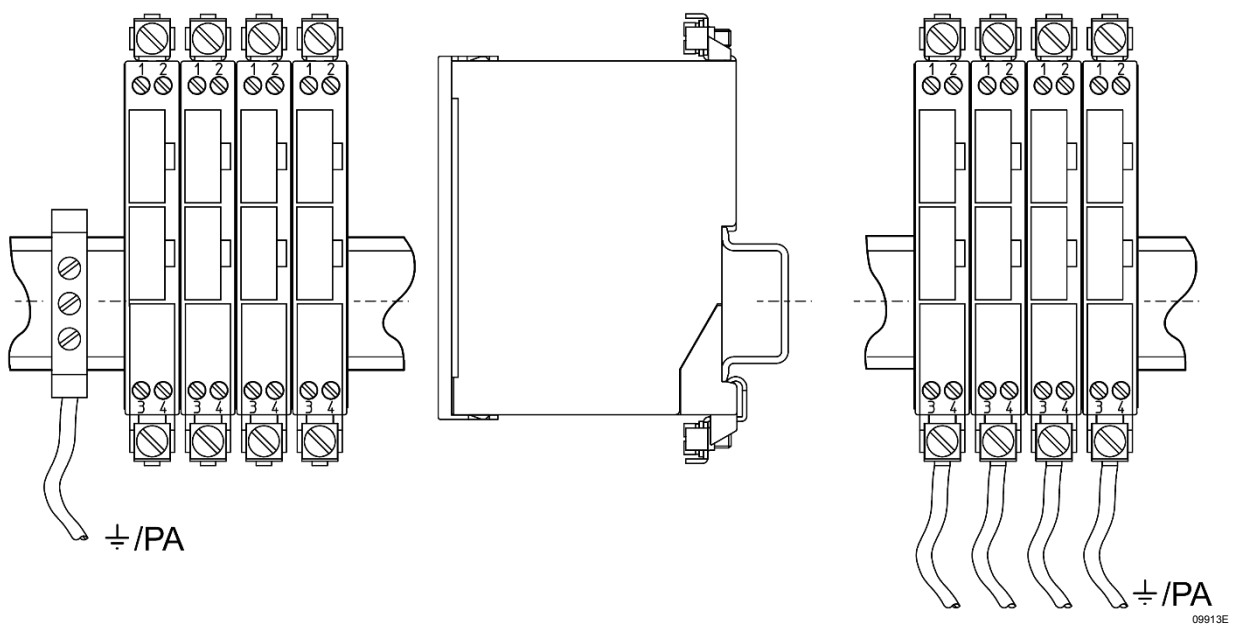

The clamping bases, which are available as accessories, offer additional options for installation. The clamping bases are installed on the safety barrier with an adaptor (mounting material can be found in the "Accessories and spare parts" chapter).

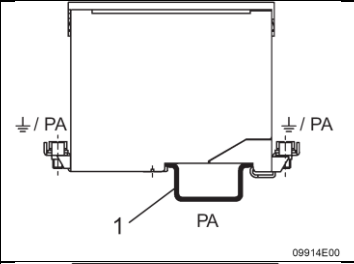
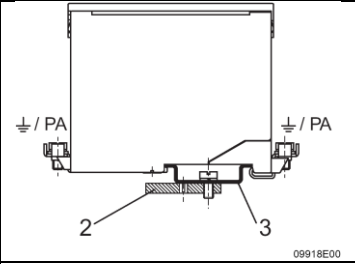
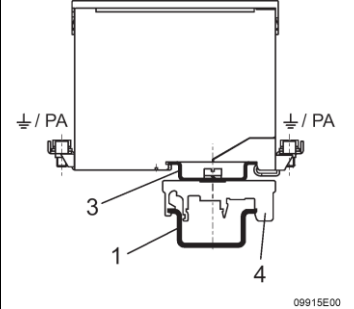
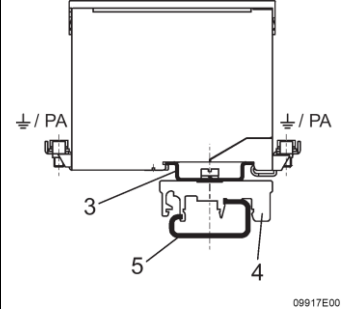
	NS 35/15 DIN rail	NS 32 DIN rail	Mounting plate or flat rail
Non-isolated installation	 <p style="text-align: center;">09914E00</p>		 <p style="text-align: center;">09918E00</p>
Isolated installation	 <p style="text-align: center;">09915E00</p>	 <p style="text-align: center;">09917E00</p>	<ol style="list-style-type: none"> 1. NS 35/15 DIN rail 2. Mounting plate 3. Adaptor item no. 158826 4. Plastic clamping base item no. 165283 5. NS 32 DIN rail

Attention:

Isolated installation means that the safety barrier is not connected to the grounding system of the DIN rail.

In this case, the safety barrier must be connected to the equipotential bonding via the \equiv / equipotential bonding terminal in order to ensure power limiting and therefore intrinsic safety.

Safety barriers must always be connected to the equipotential bonding.

4.2 Interchangeable back-up fuse



R. STAHL's safety barriers feature an interchangeable back-up fuse.

Two-channel barriers have one back-up fuse for each channel. The back-up fuse is connected upstream of the internal, inaccessible fuse. A protective circuit prevents both fuses tripping at the same time. This ensures that the safety barrier is protected from being destroyed in the event of incorrect polarity of the operating voltage or impermissibly high operating voltage.

This results in two major advantages for

maintenance and overhaul:

- The safety barrier does not need to be replaced in the event of overload
- The interchangeable back-up fuse of the barrier can be replaced without removing the barrier

The safety barrier and its back-up fuse are designed so that only one back-up fuse (I = 160 mA) is used for all barriers of Series 9001, 9002 and 9004.

This reduces the stock of spare parts to what is absolutely necessary.

Only genuine spare parts from R. STAHL may be used. For details of accessories and spare parts, see section 7.

4.3 Dimensions/fastening dimensions

Dimensional drawing (all dimensions in mm [inch]) – Subject to change

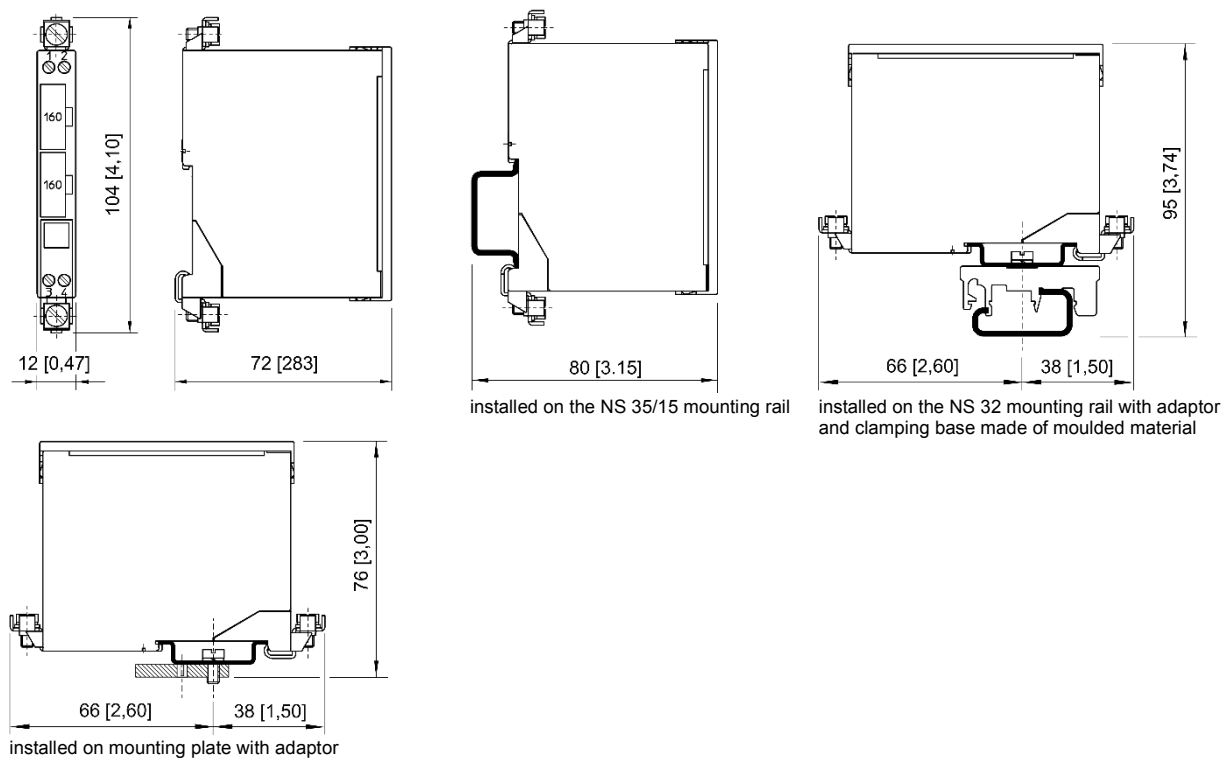

5 Selecting safety barriers

Safety barriers are generally selected in two steps:

- Functional analysis
- Safety analysis

During the functional analysis, the type of safety barrier must first be ascertained. Safety barriers of the same type use the same basic circuit but have different electrical and safety characteristic values. If multiple safety barriers are connected together, the safety characteristic values have to be adapted.

The safety barriers recommended in the quick selection (section 2) for each application are sufficient for the majority of applications. If the electrical or safety characteristic values are not sufficient, a different safety barrier of the same type can be used with suitable values.

5.1 Function – barrier type

Polarity/voltage limiting

Each channel has a polarity (+, -, ~) relative to \perp /equipotential bonding, which is decided by the direction of the voltage-limiting Zener diode. To ensure intrinsic safety, the polarity must correspond to the applied voltage.

e.g.:

Positive voltage at channel 1	=> positive polarity at channel 1
Negative voltage at channel 2	=> negative polarity at channel 2
Alternating voltage at channel 1	=> alternating polarity at channel 1

With two-channel safety barriers, it is possible to use the equipotential bonding connection of the safety barrier as a "third channel". However, this is only permitted to be used as a grounding line (like "channel 2" in the case of single-channel safety barriers). In addition, this should be done via an additional line and not via \perp /equipotential bonding.

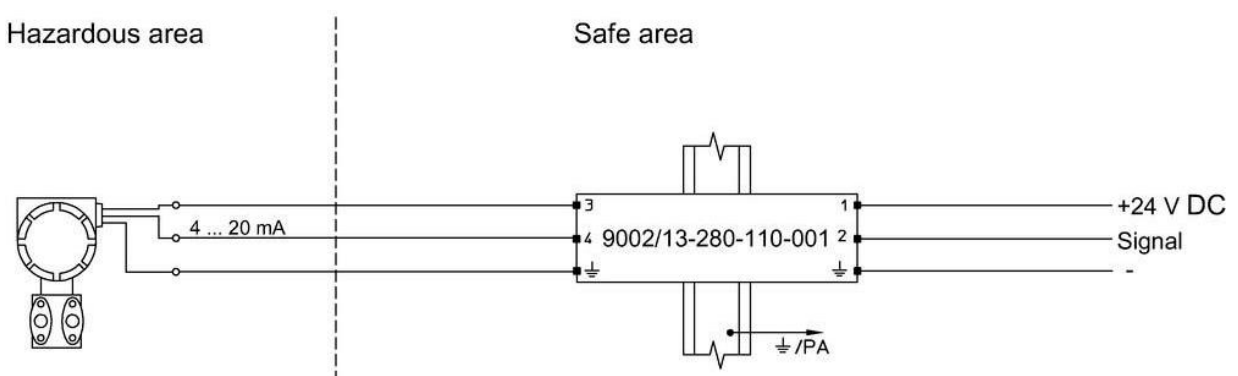

24496E_02

Correct: Return line via separate line

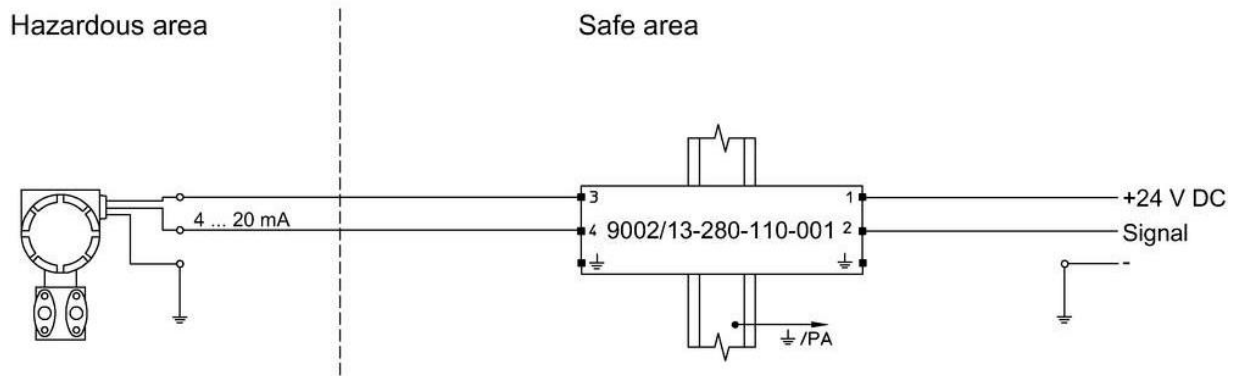

24497E_02

Incorrect: Return line via \perp /equipotential bonding without separate line

Attention:

In this type of circuit, the "-" connection of the power supply is directly connected to \perp /equipotential bonding of the safety barrier and therefore the grounding of the safety barrier. In the event of potential differences, this can cause compensating currents or potential shift.

Current limiting

The current can be limited using a resistor. As an alternative, a diode can also be used to completely block the current in one direction. Channels with a diode are called "evaluation barriers".

Evaluation barriers can only be used for DC signals; with resistors there is no limitation.

Diodes only block the current in one direction and do not limit the current level. This means that evaluation barriers can only be used with an active field device (i.e. the energy comes from the field device) or in channel 2 if a limiting resistor is installed in channel 1 (power supply).

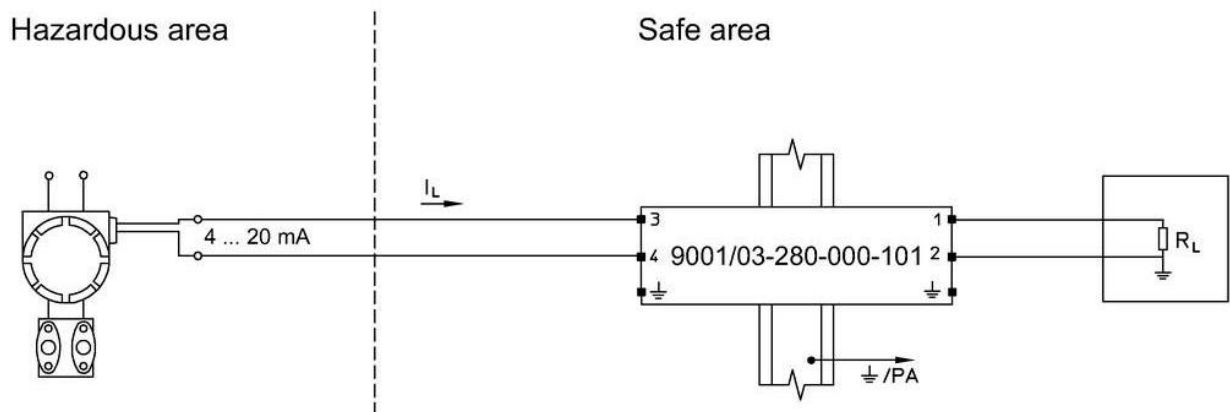

24498E_02

Active field device

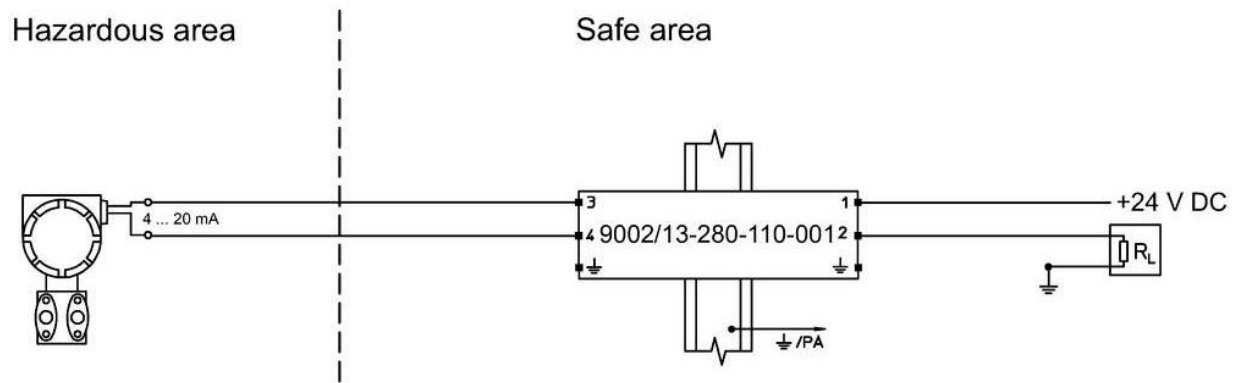

Channel 1: Resistor, channel 2: Evaluation barrier

11329E_02

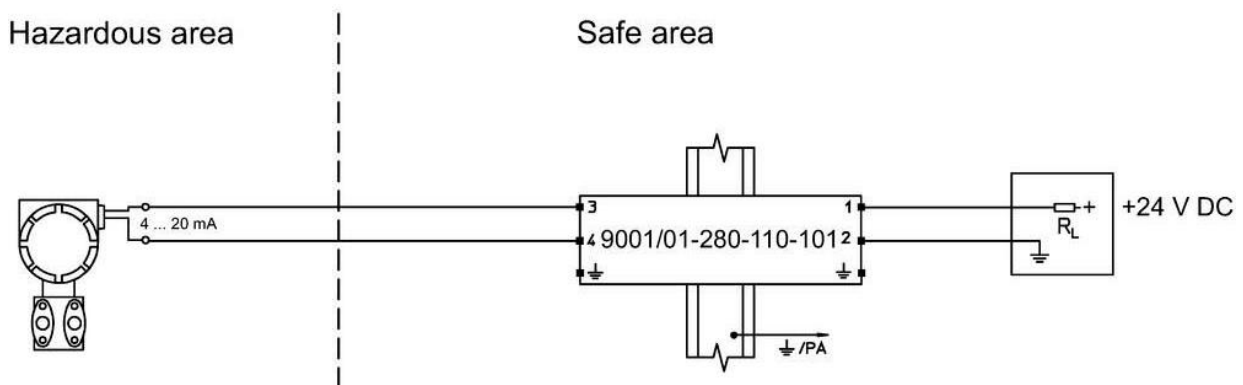

Evaluation barrier is not required as channel 2 is directly connected to ground

09952E02

It is always possible to replace an evaluation barrier with a resistor. However, evaluation barriers have far better safety characteristic values, which is why these should be used wherever possible. Since the diode completely blocks the current in the direction of the field device, I_o and P_o are greatly reduced.

With evaluation barriers, there is also a constant voltage drop across the diode, which simplifies the electrical calculations.

Safety barriers with electronic current limiting

The Series 9004 safety barriers feature electronic current limiting with a constant voltage drop instead of a resistor or diode.

Power supply

A distinction is made between regulated and unregulated power supplies. When using unregulated power supplies, a suitable safety barrier must be used.

Safety barriers for specific applications

Alongside the described standard safety barriers, there are also safety barriers which have been developed for a specific application or requirement. Some of these have additional circuits, which means that they might not behave as described above.

9001/51 for HART transmitters

These safety barriers have been designed specifically for HART transmitters. They enable bidirectional HART communication between the HART transmitter and the controller.

Single-channel safety barriers for potential-free contacts with switch

9001/01-252-060-141

This safety barrier is ideal for controlling relays.

A binary input (optocoupler) of an automation device can be operated as a load.

This safety barrier has a switching function and two electrical circuits:

If the intrinsically safe switching circuit is bridged, the non-intrinsically safe load circuit switches.

9002/77 star barriers

Star barriers (9002/77) are two-channel safety barriers with alternating polarity. Unlike standard two-channel safety barriers with alternating polarity (9002/22), the second Zener diode here has been moved to the shared connection, protecting both channels. As a result, connecting these two channels does not lead to the addition of the maximum voltage U_o (this only applies when the two channels of the star barrier are connected).

5.2 Function – electrical values

To select the right safety barrier, the electrical values that are to be used to operate the safety barrier must be determined.

- U_N : Nominal voltage
- I_N : Nominal current
- I_{max} : Maximum output current
- R_{min} : Minimum resistance value
- R_{max} : Maximum resistance value
- ΔU : Additional voltage drop (for evaluation barriers and electronic limiting)

It is important to calculate the current and voltage at the intrinsically safe field device and at the I/O assembly in the safe area. U_N is applied to the safety barrier. If the power supply is unregulated, the limited value must be used for calculations.

I_N and the resistance can be used to calculate the voltage drop across the safety barrier.

The resistance has a certain tolerance. R_{min} and R_{max} are the limits between which the resistance value lies. The most unfavourable value for the application must be used for the calculations.

For evaluation barriers and safety barriers with electronic current limiting, the voltage drop ΔU decreases regardless of the flowing current. If the applied voltage is less than ΔU , no current is flowing.

The safety barrier must be selected so that the current and voltage at the intrinsically safe field device and at the I/O assembly in the safe area are sufficient for them to work properly.



An improvement in the electrical values generally means a worsening of the safety characteristic values

5.3 Safety – Ex i values

The maximum safety characteristic values of an individual safety barrier (single-channel or two-channel) are defined by the certificate:

- Maximum voltage U_o
- Maximum current I_o
- Maximum power P_o
- Permissible external capacitance C_o
- Permissible external inductance L_o

However, it must be checked whether the selected safety barrier complies with the permissible maximum safety characteristic values of the intrinsically safe apparatus (i.e. the field device in the hazardous area).

Associated	U_o	\leq	U_i	Intrinsically safe apparatus (field device)
apparatus	I_o	\leq	I_i	
(safety barrier)	P_o	\leq	P_i	
	C_o	\geq	$C_i + C_c$	
	L_o	\geq	$L_i + L_c$	

The intrinsic safety rules as defined in the applicable standards must be followed.

5.4 Safety – connection

If multiple safety barriers are connected together, for safety reasons the possibility of current and voltage additions must be considered (examples 1 and 2). The maximum values for U_o , I_o and P_o permitted for a connection, as well as the resulting permissible maximum values for C_o and L_o , can be found in the ignition limit curves for the various explosion groups (see EN 60079-11). Alternatively, the value pairs for jointly occurring C_i and L_i can also be used. These can be ascertained from EN 60079-25.

For two-channel safety barriers, the values for connecting the two channels are already stated in the EC Type Examination Certificate wherever possible.

Example 1: Parallel connection

Connecting two safety barriers for positive potential.

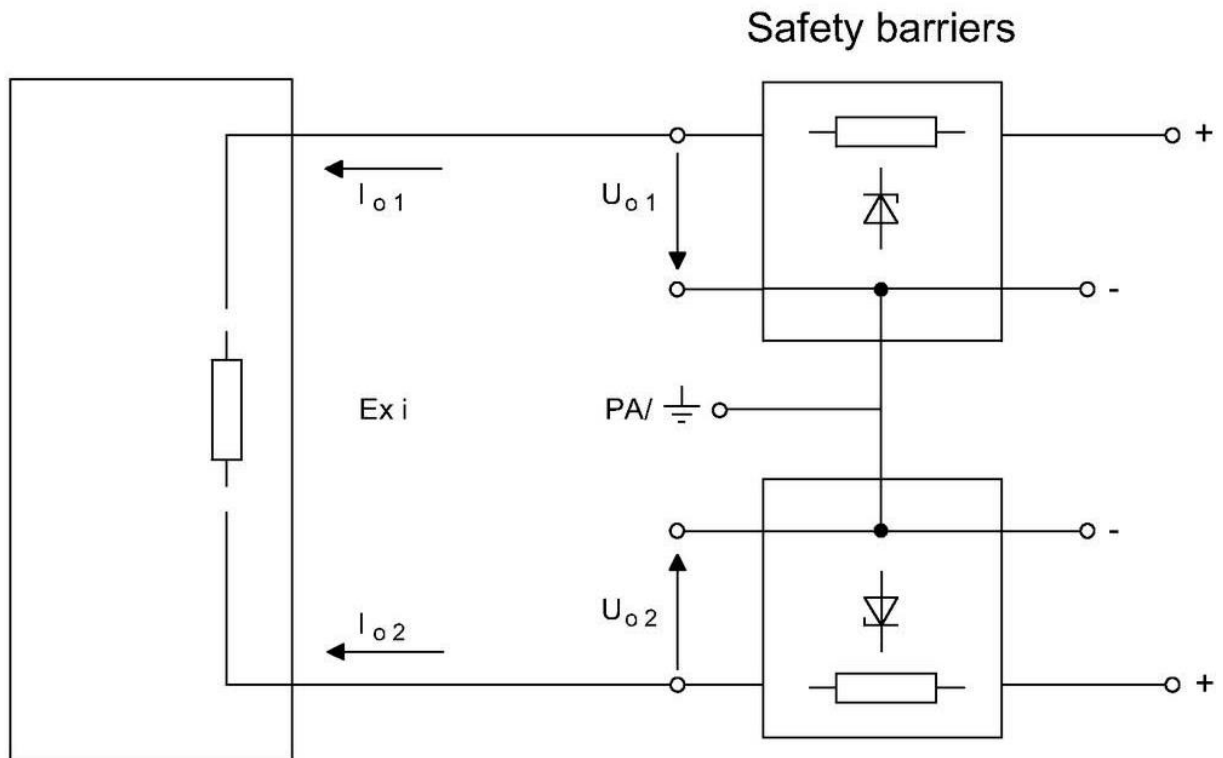

24499E_02

This results in a safety-relevant current addition, i.e. $I_o = I_{o1} + I_{o2}$

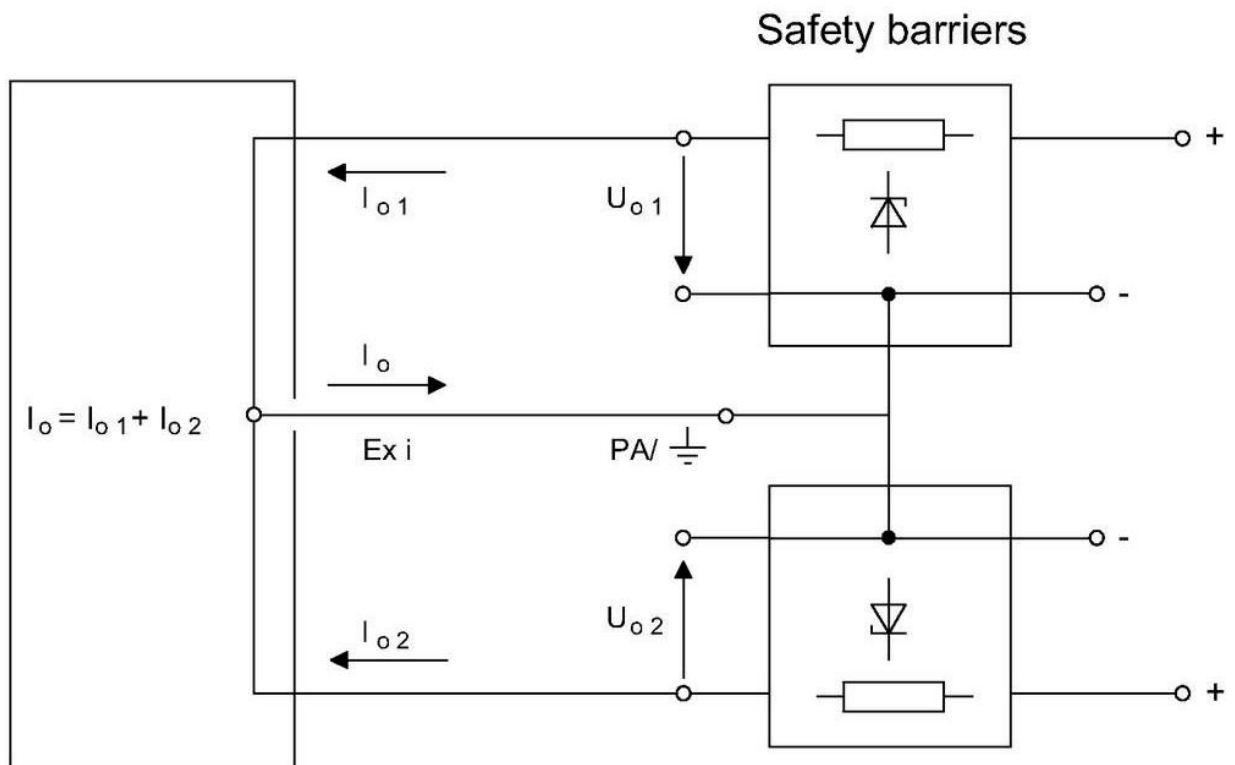

24500E_02

The new voltage U_o is the greater of the two values U_{o1} and U_{o2} , i.e. $U_o = \max. (U_{o1}, U_{o2})$

Example 2: Series connection

Connecting two safety barriers for positive and negative potential.

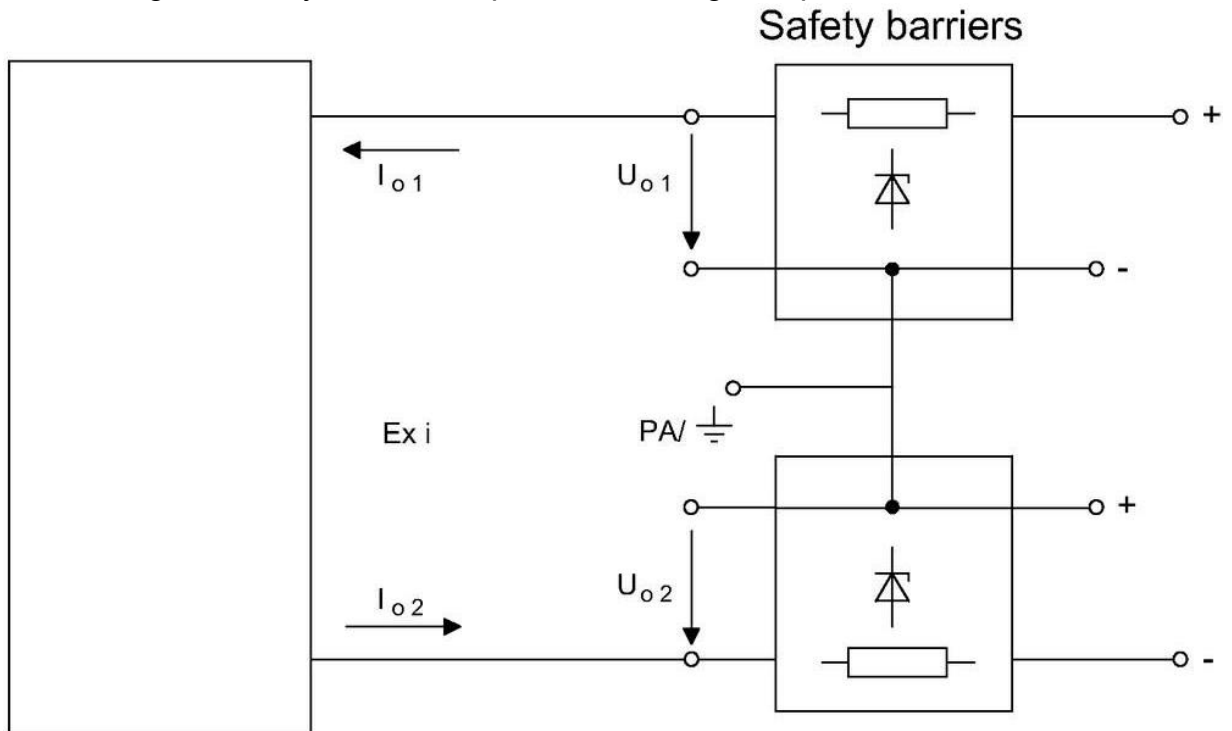

24563E_02

This results in a safety-relevant voltage addition, i.e. $U_o = U_{o1} + U_{o2}$

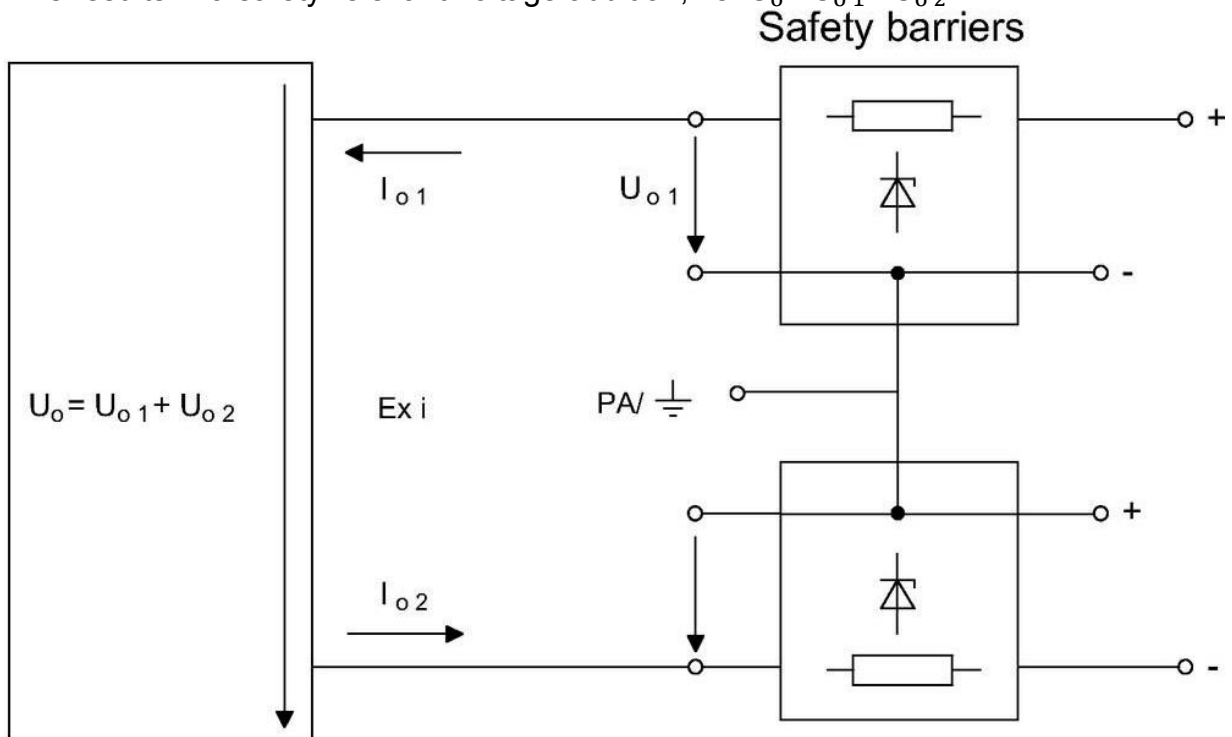

24501E_02

The new current is the greater of the two currents I_{o1} and I_{o2} , i.e.

$$I_o = \max. (I_{o1}, I_{o2})$$

Overview of addition options

Polarity	-	+	~
-	I	U	I and U
+	U	I	I and U
~	I and U	I and U	I and U

I = current addition

U = voltage addition

Connecting two barriers for alternating potential gives I and U, which means that a current addition as well as a voltage addition needs to be taken into consideration. The exception to this are star barriers (9002/77) in which the second Zener diode has been moved to the shared equipotential bonding connection, protecting both channels. As a result, connecting these two channels does not lead to the addition of the maximum voltage U_o (this only applies when the two channels of the star barrier are connected).

EN 60079-11, tables A.1 and A.2 and the ignition limit curve figures A.4 and A.6 contain the permissible maximum safety characteristic values for:

- Voltage U_o
- Current I_o
- External capacitance C_o
- External inductance L_o

Alternatively, the value pairs for jointly occurring C_i and L_i can be calculated from figures C.7 and C.8 in EN 60079-25. P_o results from $P_o = P_{o1} + P_{o2}$

Connecting safety barriers

The following procedure must be adopted:

1. Determining the new U_o and I_o values

Example: PT100 3-wire circuit

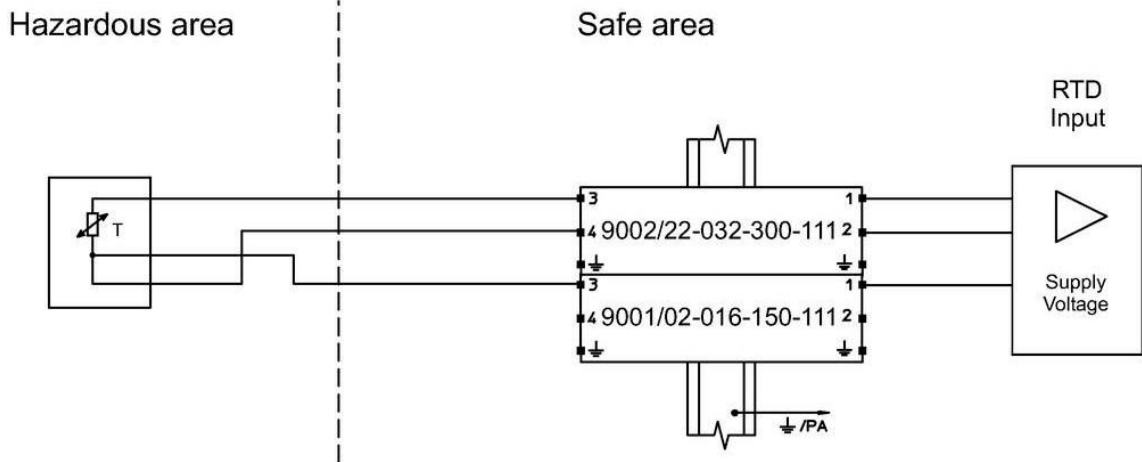

24499E_02

Since safety barriers with alternating potential are used, both the currents and the voltages at the intrinsically safe apparatus have to be added. Two wires are connected to the bottom connection, which is why the greater of the two voltages applies.

$$U_o = 1.6 \text{ V} + \max. (1.6 \text{ V}; 1.6 \text{ V}) = 3.2 \text{ V}$$

$$I_o = 300 \text{ mA} + 150 \text{ mA} = 450 \text{ mA}$$

2. Checking whether the determined value combination U_o and I_o is permissible

Example:

$$U_o = 24 \text{ V}$$

$$I_o = 210 \text{ mA}$$

According to 60079-11 table A.1:

$$\text{IIC, ia: max. } I_o = 174 \text{ mA}$$

$$\text{IIB, ia: max. } I_o = 433 \text{ mA}$$

The values are permissible for IIB but not for IIC.

3. Determining the capacitance C_o from the voltage U_o

Example:

$$U_o = 19.9 \text{ V}$$

Determining the values according to 60079-11 table A.2:

$$\text{IIC: } C_o = 0.223 \text{ } \mu\text{F}$$

$$\text{IIB: } C_o = 1.42 \text{ } \mu\text{F}$$

4. Determining the inductance L_o from the current I_o

Example:

$$U_o = 19.9 \text{ V}$$

$$I_o = 285 \text{ mA}$$

With $285 \text{ mA} * 1.5 = 427.5 \text{ mA}$

(multiplied by a safety factor of 1.5 due to ia)

Determining the values according to 60079-11 figure A.6

IIC: $L_o = 0.2 \text{ mH}$

Determining the values according to 60079-11 figure A.4

IIB: $L_o = 1.8 \text{ mH}$

5. Comparison with the intrinsically safe values of the field device (see section 5.3)

The ignition limit curves according to EN 60079-11 must not be used to assess intrinsic safety for interconnecting the barriers with electronic current limiting (Series 9004).

A suitable process is described in EN 60079-25.

Verification of intrinsic safety by R. STAHL

R. STAHL creates cost-effective verification and documentation of intrinsically safe circuits. R. STAHL also offers seminars on intrinsic safety including creating verification of intrinsic safety.

For more information, see:

<https://r-stahl.com/en/global/services-and-seminars/proof-of-intrinsic-safety/>

6 Example applications

2-wire 4/20 mA transmitters

Regulated power supply | Precision resistor in the supply line | Grounded field circuit

Safety barrier used: 9001/01-280-110-101

[Go to the quick selection](#)

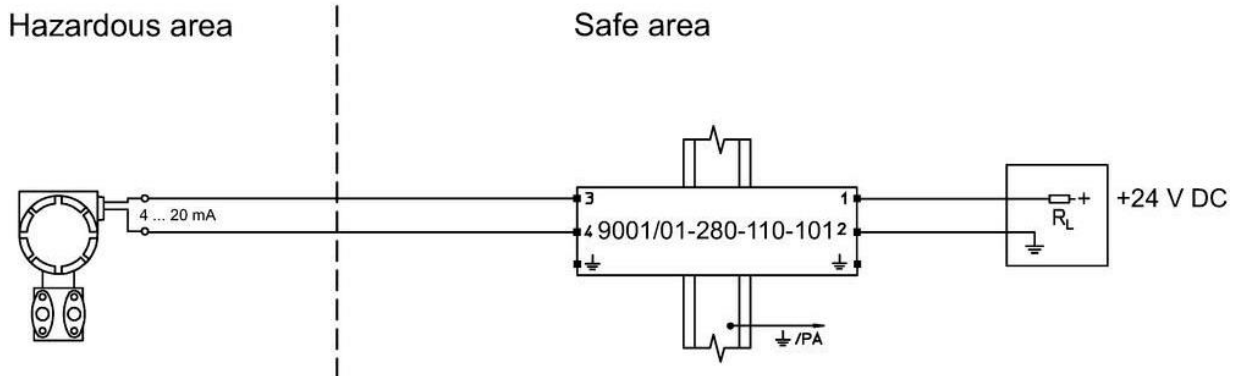

09952E02

Operating data

Operating voltage	$U_N = +24\text{ V}$
Operational current	$I_N = 0\text{ to }22\text{ mA}$
Maximum resistance of the safety barrier	$R_{\max} = 294\ \Omega$
Maximum voltage drop at the safety barrier	$\Delta U_{\max_S} \leq 22\text{ mA} * 294\ \Omega \approx 6.5\text{ V}$
Precision resistor R_L	Assumed: $R_L = 250\ \Omega$
Maximum voltage drop at the precision resistor	$\Delta U_{\max_R} \leq 22\text{ mA} * 250\ \Omega = 5.5\text{ V}$
Current/voltage at the field device	At 0 mA: +24 V At 22 mA: +12 V

Safety data

Maximum voltage	$U_o = 28\text{ V}$		
Maximum current	$I_o = 110\text{ mA}$		
Maximum power	$P_o = 770\text{ mW}$		
Maximum permissible external inductance	L_o	IIC 2.2 mH	IIB 9 mH
Maximum permissible external capacitance	C_o	IIC 0.08 μF	IIB 0.65 μF

Application note

Due to a total resistance of $\geq 230\ \Omega$, this safety barrier can transmit HART signals.

2-wire 4/20 mA transmitters

Regulated power supply | Precision resistor in the supply or return line | Grounded field circuit

Safety barrier used: 9002/13-280-110-001

⇒ [Go to the quick selection](#)

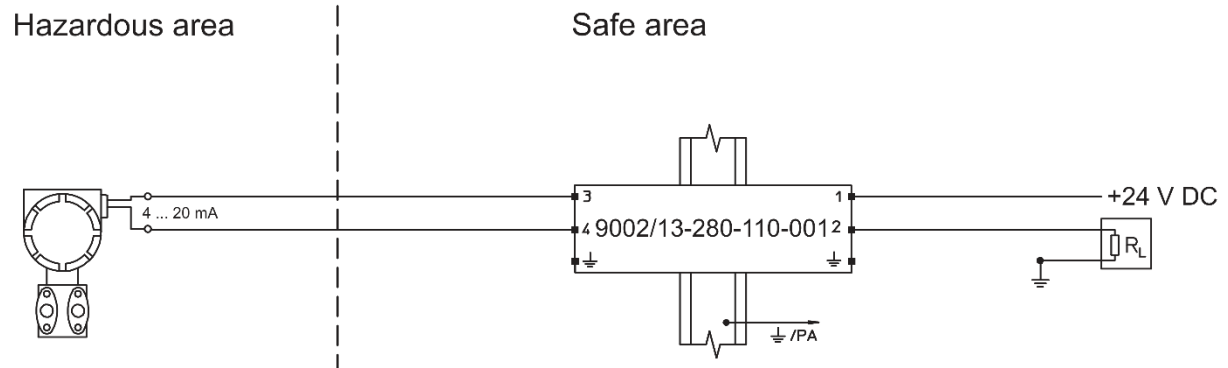

11329E_02

Operating data

Operating voltage	$U_N = +24\text{ V}$
Operational current	$I_N = 0\text{ to }22\text{ mA}$
Maximum resistance of the safety barrier	$R_{\max} = 296\ \Omega$
Maximum voltage drop at channel 1 of the safety barrier	$\Delta U_{\max_S} \leq 22\text{ mA} * 296\ \Omega \approx 6.51\text{ V}$
Additional voltage drop at the diode	$\Delta U = 2\text{ V}$
Precision resistor R_L	Assumed: $R_L = 100\ \Omega$
Maximum voltage drop at the precision resistor	$\Delta U_{\max_R} \leq 22\text{ mA} * 100\ \Omega = 2.2\text{ V}$
Current/voltage at the field device	At 0 mA: +24 V At 22 mA: +13.29 V

Safety data

Maximum voltage	$U_o = 28\text{ V}$		
Maximum current	$I_o = 110\text{ mA}$		
Maximum power	$P_o = 770\text{ mW}$		
Maximum permissible external inductance	L_o	IIC 1.25 mH	IIB 9 mH
Maximum permissible external capacitance	C_o	IIC 0.08 μF	IIB 0.635 μF

Application note

Due to a total resistance of $\geq 230\ \Omega$, this safety barrier can transmit HART signals.

2-wire 4/20 mA HART transmitters

Unregulated power supply | Precision resistor in the return line | Grounded field circuit

Safety barrier used: 9001/51-280-110-141

[Go to the quick selection](#)

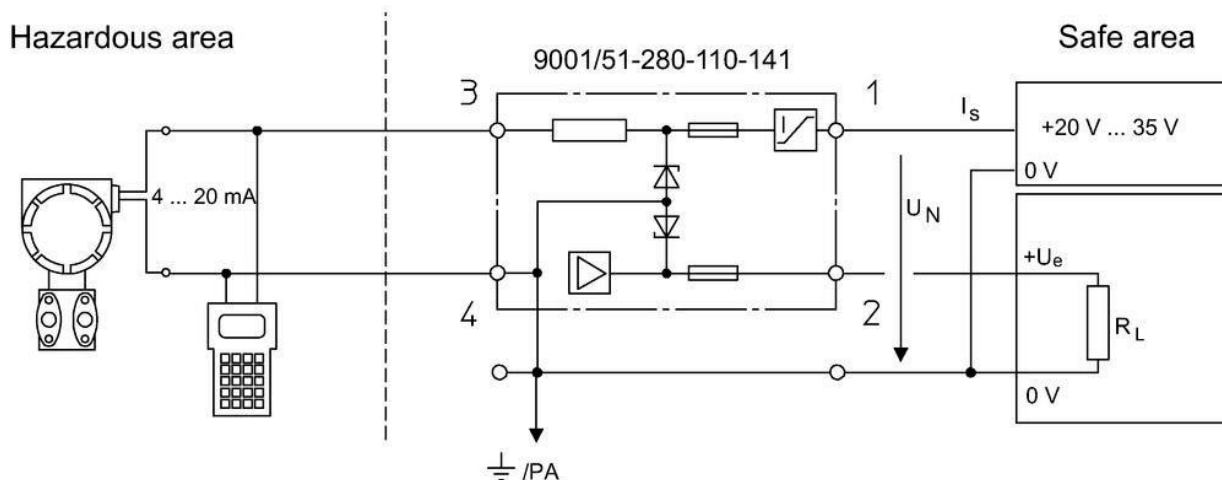

24502E_02

Operating data

Operating voltage	$U_N = +20 \text{ to } 35 \text{ V DC}$	
Supply current (terminal 1)	$I_S \leq 50 \text{ mA}$	
Operational current	$I_N = 3.6 \text{ to } 22 \text{ mA}$	
Maximum precision resistor	$U_N \leq 23.5 \text{ V}$	$U_N > 23.5 \text{ V}$
	$R_L \leq 500 \Omega$	$R_L \leq 750 \Omega$
Operating voltage of the transmitter	$U_N \leq 23.5 \text{ V}$	$U_N \geq 23.5 \text{ V}$
	At $I_N = 20 \text{ mA}$	
	$U_{\min} = U_N - 8.5 \text{ V}$	$U_{\min} = 15 \text{ V}$

Safety data

Maximum voltage	$U_o = 28 \text{ V}$		
Maximum current	$I_o = 110 \text{ mA}$		
Maximum power	$P_o = 770 \text{ mW}$		
Maximum permissible external inductance	L_o	IIC	IIB
		1.2 mH	9 mH
Maximum permissible external capacitance	C_o	IIC	IIB
		0.083 μF	0.65 μF

Application note

The 9002/13-280-110-001 safety barrier can be used with regulated operating voltages $U_N \leq 24 \text{ V}$. This safety barrier is designed specifically for HART signals.

3-wire 4/20 mA transmitters

Regulated power supply | Grounded field circuit
 Safety barrier used: 9002/13-280-110-001

⇒ [Go to the quick selection](#)

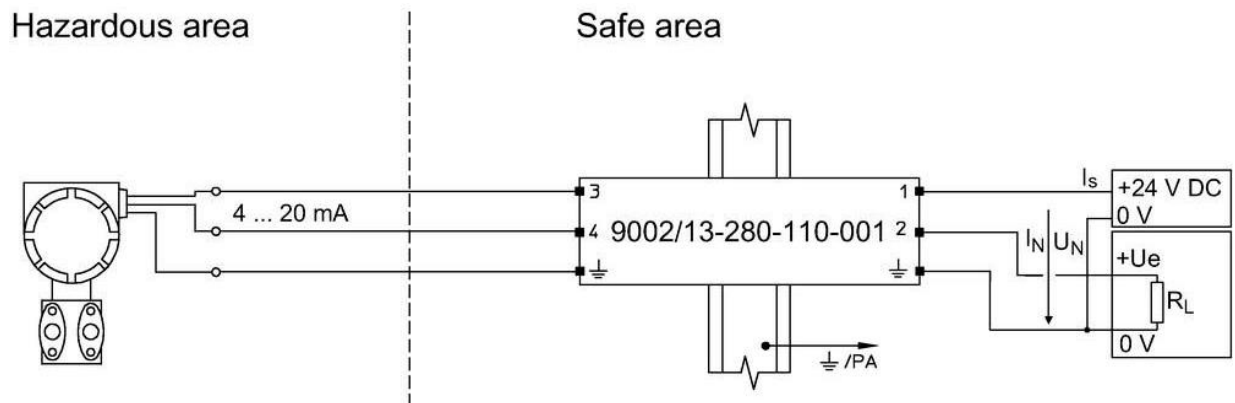

24503E_02

Operating data

Operating voltage	$U_N = + 24 \text{ V}$
Operational current	$I_N = 3.6 \text{ to } 22 \text{ mA}$
Maximum resistance of the safety barrier	$R_{\text{max}} = 296 \ \Omega$
Voltage drop in the signal path	$\Delta U = 2 \text{ V}$
Supply current (terminal 1)	$I_{S\text{max}} = 82 \text{ mA}$ $I_S = I_N + I_{\text{Field device}}$ [assumed $I_S = 30 \text{ mA}$]
Maximum voltage drop of auxiliary power	$\Delta U_{\text{max}} \leq 30 \text{ mA} * 296 \ \Omega \approx 8.9 \text{ V}$
Current/voltage at the field device	30 mA/15.1 V
Maximum load resistance	$R_L = (24 \text{ V} - 8.9 \text{ V} - 2 \text{ V})/22 \text{ mA} \approx 596 \ \Omega$

Safety data

Maximum voltage	$U_o = 28 \text{ V}$
Maximum current	$I_o = 110 \text{ mA}$
Maximum power	$P_o = 770 \text{ mW}$

According to EN 60079-11:

Maximum permissible external inductance	L_o	IIC	IIB
		1.25 mH	9 mH
Maximum permissible external capacitance	C_o	IIC	IIB
		0.08 μF	0.635 μF

2-wire 4/20 mA analogue output (power source) for I/P converters, etc.

Regulated power supply | Regulation in the supply line | Grounded field circuit

Safety barrier used: 9001/01-280-110-101

[Go to the quick selection](#)

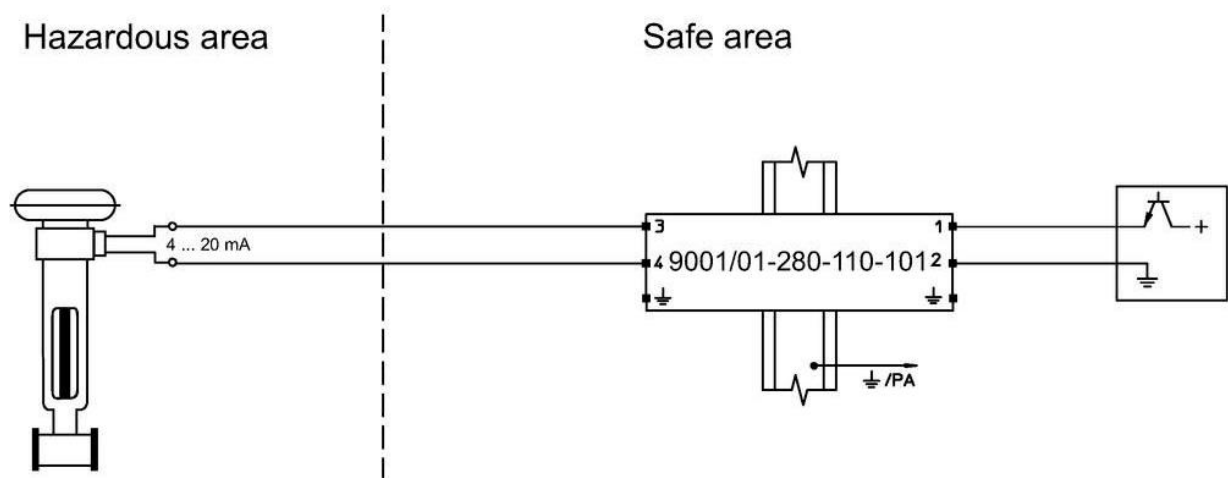

11331E02

Operating data

Operating voltage	$U_N = +24\text{ V}$
Operational current	$I_N = 0\text{ to }22\text{ mA}$
Maximum resistance of the safety barrier	$R_{\max} = 294\ \Omega$
Maximum voltage drop at the safety barrier	$\Delta U_{\max} \leq 22\text{ mA} * 294\ \Omega \approx 6.5\text{ V}$
Current/voltage at the field device	At 0 mA: +24 V At 22 mA: +17.5 V
Maximum load	$L_{\max} = 17.5\text{ V}/22\text{ mA} \approx 796\ \Omega$

Safety data

Maximum voltage	$U_o = 28\text{ V}$		
Maximum current	$I_o = 110\text{ mA}$		
Maximum power	$P_o = 770\text{ mW}$		
Maximum permissible external inductance	L_o	IIC 2.2 mH	IIB 9 mH
Maximum permissible external capacitance	C_o	IIC 0.08 μF	IIB 0.65 μF

2-wire 4/20 mA analogue output I/P converters/control valves – standard and HART

Regulated power supply | Regulation in the return line | Ungrounded field circuit

Safety barrier used: 9002/13-280-110-001

[Go to the quick selection](#)

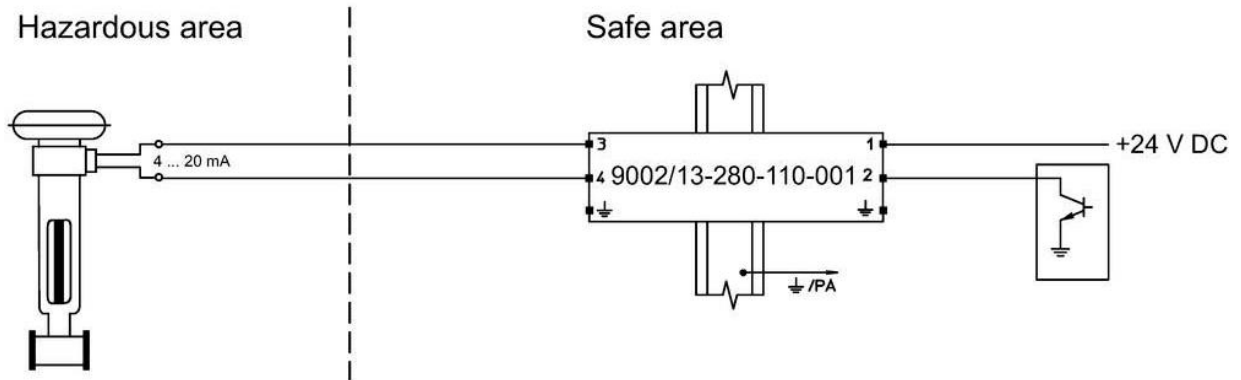

11334E02

Operating data

Operating voltage	$U_N = +24 \text{ V}$
Operational current	$I_N = 0 \text{ to } 22 \text{ mA}$
Maximum resistance of the safety barrier	$R_{\max} = 296 \ \Omega$
Maximum voltage drop at the safety barrier	$\Delta U_{\max_S} \leq 22 \text{ mA} * 296 \ \Omega + 2 \text{ V} \approx 8.5 \text{ V}$
Current/voltage at the field device	At 0 mA: +24 V At 22 mA: +15.5 V
Maximum load	$L_{\max} = 15.5 \text{ V}/22 \text{ mA} \approx 705 \ \Omega$

Safety data

Maximum voltage	$U_o = 28 \text{ V}$		
Maximum current	$I_o = 110 \text{ mA}$		
Maximum power	$P_o = 770 \text{ mW}$		
Maximum permissible external inductance	L_o	IIC 1.25 mH	IIB 9 mH
Maximum permissible external capacitance	C_o	IIC 0.08 μF	IIB 0.635 μF

Application note

This safety barrier is used if the automation system activates the analogue output signal in the return (negative) line.

2-wire binary output (power source) for solenoid valves, LEDs and audible alarm indicators

Regulated power supply | Regulation in the supply line | Grounded field circuit

Safety barrier used: 9001/01-280-110-101

[Go to the quick selection](#)

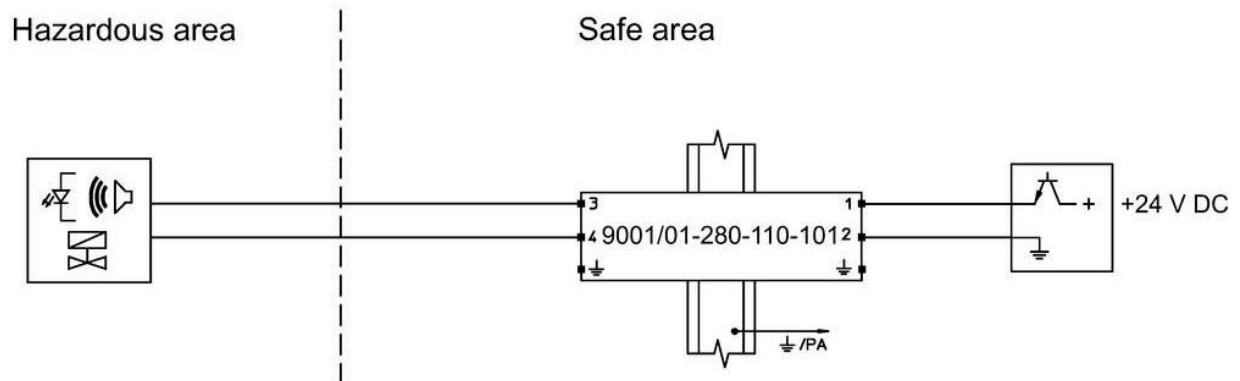

06603E_02

Operating data

Operating voltage

$$U_N = + 24 \text{ V}$$

Maximum resistance of the safety barrier

$$R_{\max} = 296 \ \Omega$$

Voltage at the field device

$$U = U_N - I * R_{\max}$$

Current/voltage at the field device

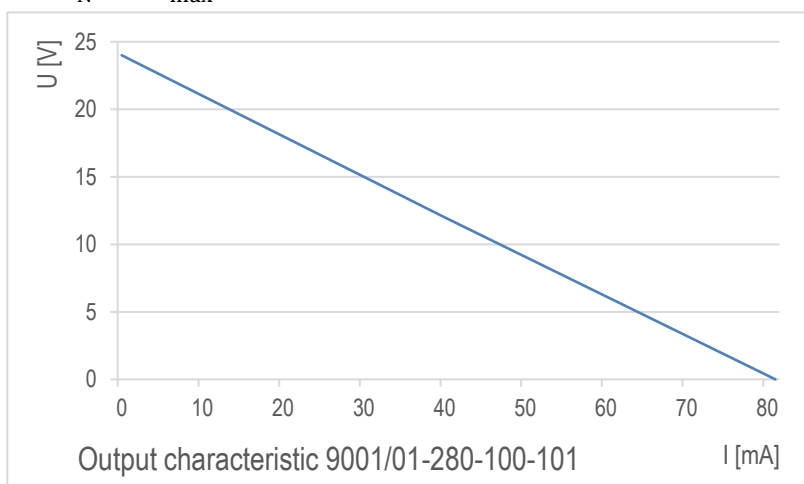

Safety data

Maximum voltage

$$U_o = 28 \text{ V}$$

Maximum current

$$I_o = 110 \text{ mA}$$

Maximum power

$$P_o = 770 \text{ mW}$$

Maximum permissible external inductance

L_o	IIC	IIB
	2.2 mH	9 mH

Maximum permissible external capacitance

C_o	IIC	IIB
	0.08 μF	0.65 μF

Application note

For applications which require a higher power and for general use in gas groups IIB and IIA, 9001/01-280-165-101 and 9001/01-280-280-101 should be used.

2-wire binary output (power source) for solenoid valves, LEDs and audible alarm indicators

Regulated power supply | Regulation in the return line | Ungrounded field circuit

Safety barrier used: 9002/13-280-110-001

[Go to the quick selection](#)

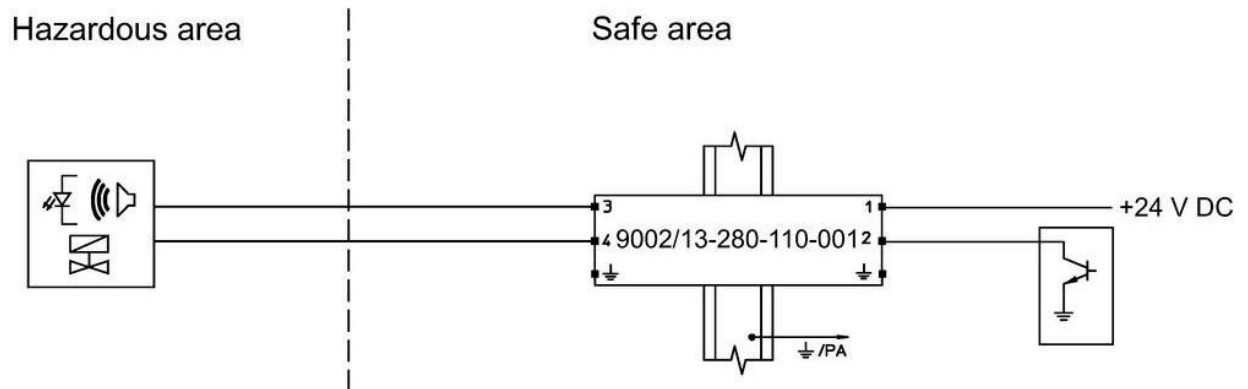

06605E_02

Operating data

Operating voltage	$U_N = +24\text{ V}$
Maximum resistance of the safety barrier	$R_{\max} = 296\ \Omega$
Additional voltage drop at the diode	$\Delta U = 2\text{ V}$
Voltage at the field device	$U = U_N - \Delta U - I * R_{\max}$
Current/voltage at the field device	

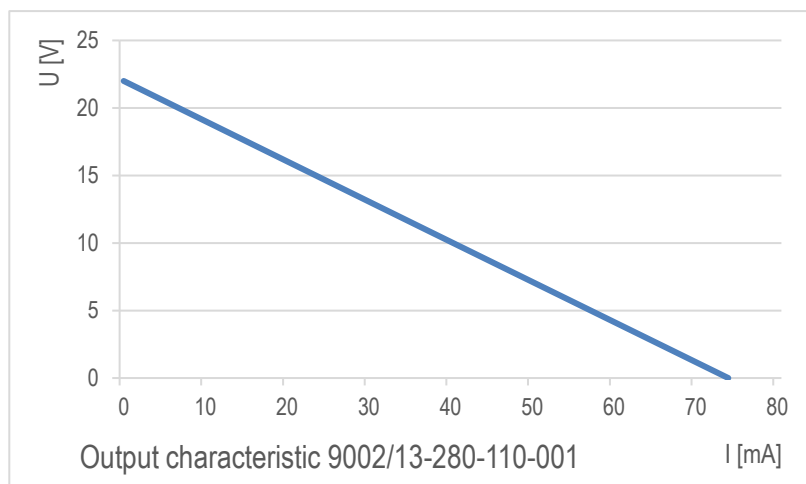

Safety data

Maximum voltage	$U_o = 28\text{ V}$		
Maximum current	$I_o = 110\text{ mA}$		
Maximum power	$P_o = 770\text{ mW}$		
Maximum permissible external inductance	L_o	IIC 1.25 mH	IIB 9 mH
Maximum permissible external capacitance	C_o	IIC 0.08 μF	IIB 0.635 μF

2-wire binary output (power source) for solenoid valves, LEDs and audible alarm indicators

Unregulated power supply | Regulation in the supply line | Grounded field circuit

Safety barrier used: 9001/01-252-100-141

[Go to the quick selection](#)

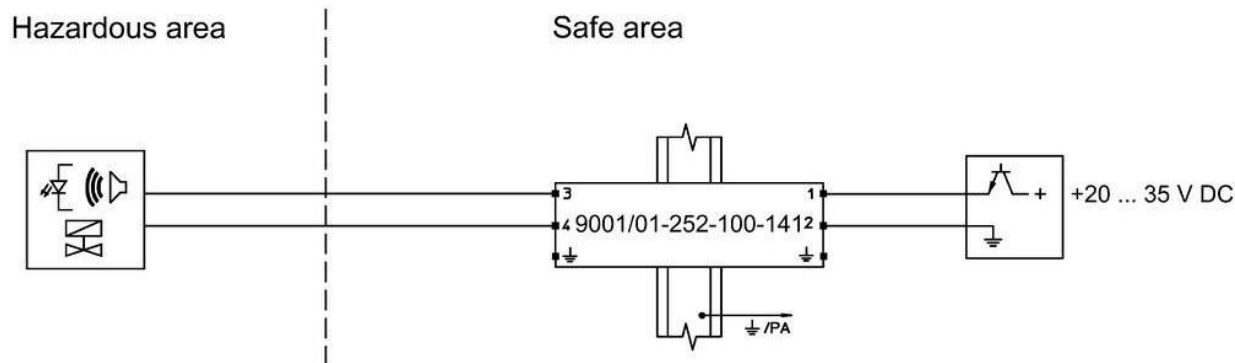

06602E_02

Operating data

Operating voltage	$U_N = + 20 \text{ to } 35 \text{ V DC}$	
Maximum resistance of the safety barrier	$R_{\max} = 268 \ \Omega$	
No-load output voltage (3 -> 4, $I_N = 0$)	$U_N \leq 24 \text{ V}$ $U_L = U_N - 3 \text{ V}$	$U_N > 24 \text{ V}$ $U_L = 21 \text{ V}$
Operational current	$I_N = U_L / (268 \ \Omega + R_L)$	

Safety data

Maximum voltage	$U_o = 25.2 \text{ V}$	
Maximum current	$I_o = 100 \text{ mA}$	
Maximum power	$P_o = 630 \text{ mW}$	
Maximum permissible external inductance	L_o	IIC: 2 mH IIB: 11 mH
Maximum permissible external capacitance	C_o	IIC: 0.107 μF IIB: 0.82 μF

Application note

Channel 1: Leakage current from 1 mA to max 10 mA. Voltage is limited to 21 V.

2-wire binary output (power source) for solenoid valves, LEDs and audible alarm indicators

Unregulated power supply | Regulation in the return line | Ungrounded field circuit

Safety barrier used: 9002/13-252-121-041

[Go to the quick selection](#)

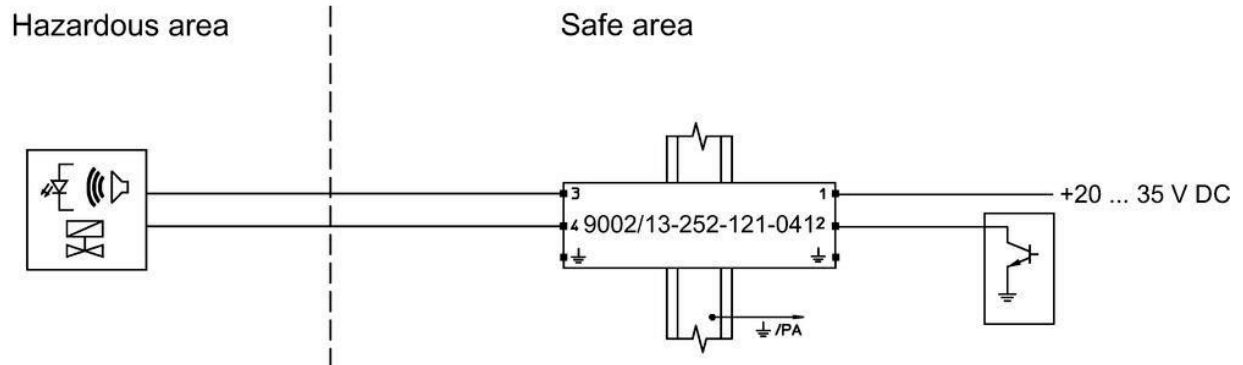

06604E_02

Operating data

Operating voltage	$U_N = + 20 \text{ to } + 35 \text{ V}$	
Maximum resistance of the safety barrier	$R_{\max} = 244 \ \Omega$	
No-load output voltage (3 -> 4, $I_N = 0$)	$U_N \leq 24 \text{ V}$	$U_N > 24 \text{ V}$
	$U_L = U_N - 3.5 \text{ V}$	$U_L = 21 \text{ V}$
Operational current	$I_N = U_L / (244 \ \Omega + R_L + R_{\text{Switch}})$	

Safety data

Maximum voltage	$U_o = 25.2 \text{ V}$		
Maximum current	$I_o = 121 \text{ mA}$		
Maximum power	$P_o = 760 \text{ mW}$		
Maximum permissible external inductance	L_o	IIC 1.25 mH	IIB 7.35 mH
Maximum permissible external capacitance	C_o	IIC 0.104 μF	IIB 0.8 μF

Application note

This barrier is suitable for use with an unregulated power supply and ungrounded return lines. Only for channel 1: Leakage current from 1 mA to max 10 mA. Voltage is limited to 21 V, additional voltage drop ΔU increases to up to 3.5 V as the voltage decreases.

2-wire binary output (power source) for multiple solenoid valves, LEDs and audible alarm indicators

Regulated power supply | Regulation in the supply line | Grounded field circuit

Safety barrier used: 9002/11-280-186-001

[Go to the quick selection](#)

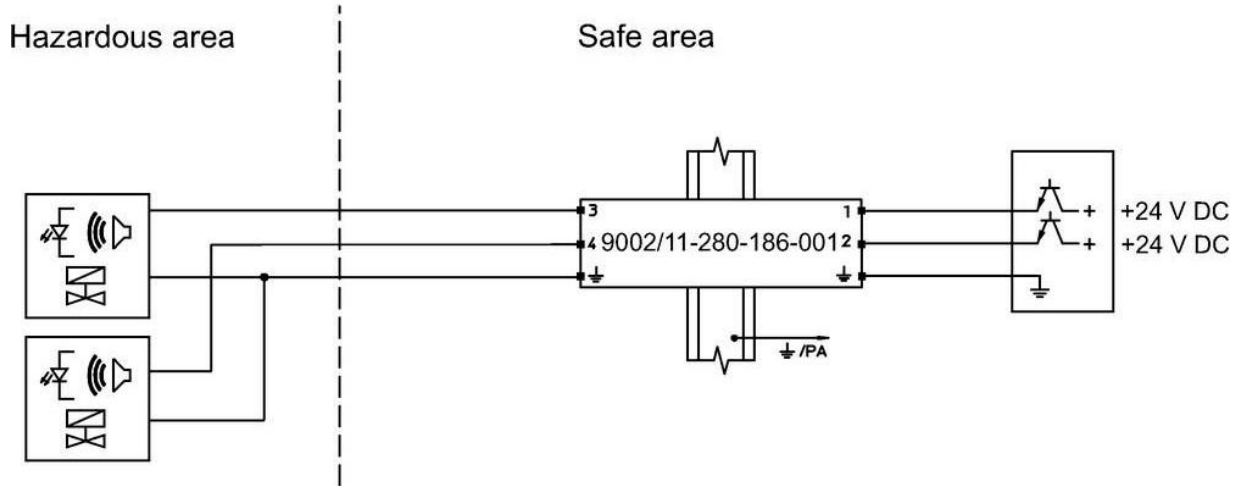

06606E_02

Operating data

Operating voltage

$$U_N = +24 \text{ V}$$

Maximum resistance of the safety barrier per channel

$$R_{\max} = 359 \Omega$$

Voltage at the field device

$$U = U_N - \Delta U - I * R_{\max}$$

Current/voltage at the field device

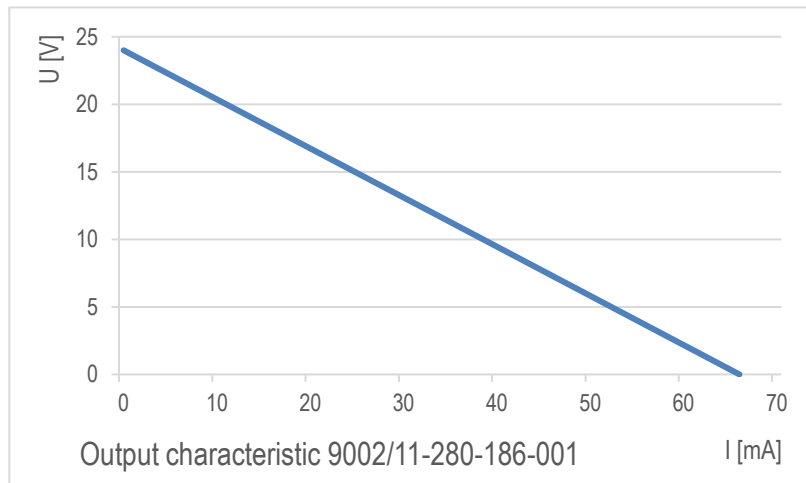

Safety data

Maximum voltage

$$U_o = 28 \text{ V}$$

Maximum current

$$I_o = 186 \text{ mA}$$

Maximum power

$$P_o = 1300 \text{ mW}$$

Maximum permissible external inductance

L_o	IIC	IIB
-	-	2.8 mH

Maximum permissible external capacitance

C_o	IIC	IIB
-	-	0.551 μF

3-wire PNP inputs (positive circuit) of proximity switches, photoresistors and encoders

Regulated power supply | Grounded field circuit

Safety barrier used: 9002/13-280-110-001

[Go to the quick selection](#)

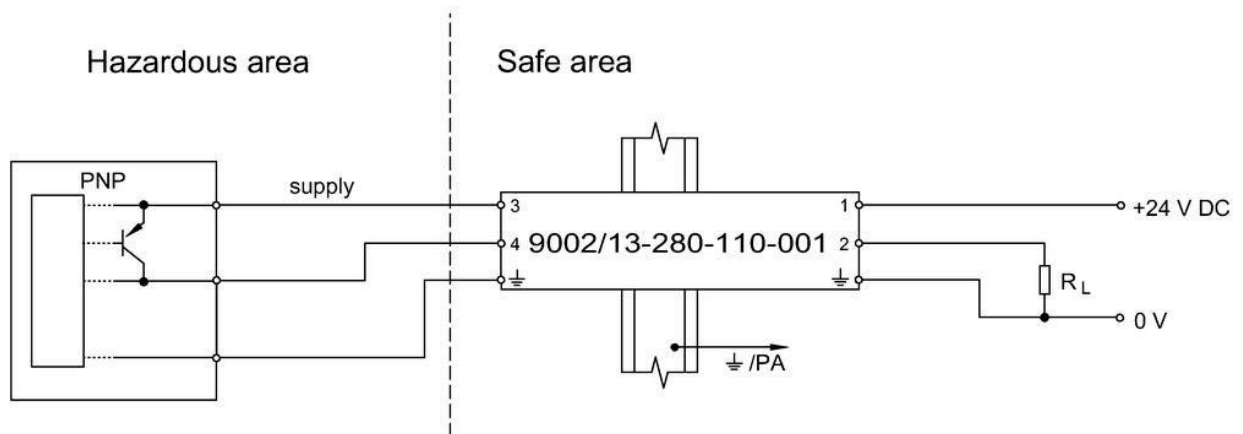

24504E_02

Operating data

Operating voltage	$U_N = + 24 \text{ V}$
Maximum resistance of the safety barrier	$R_{\text{max}} = 296 \ \Omega$
Additional voltage drop	Safety barrier diode: $\Delta U = 2 \text{ V}$ Assumed: Field device: $\Delta U \leq 2 \text{ V}$
Field device no-load current	Assumed: $I_{\text{Field device}} \leq 10 \text{ mA}$
Current through the load	Assumed: $I_L = 20 \text{ mA}$
Voltage at the load	$U_L = 24 \text{ V} - (296 \ \Omega * 30 \text{ mA}) - 2 \text{ V} - 2 \text{ V} \approx 11.1 \text{ V}$
Maximum load (at $I_L = 20 \text{ mA}$)	$L_{\text{max}} = 11.1 \text{ V} / 20 \text{ mA} \approx 557 \ \Omega$

Safety data

Maximum voltage	$U_o = 28 \text{ V}$		
Maximum current	$I_o = 110 \text{ mA}$		
Maximum power	$P_o = 770 \text{ mW}$		
Maximum permissible external inductance	L_o	IIC -	IIB 2.8 mH
Maximum permissible external capacitance	C_o	IIC -	IIB 0.551 μF

Application note

With this barrier, all loop voltages must be checked to ensure correct functioning.

3-wire NPN inputs (negative circuit) of proximity switches, photoresistors and encoders

Regulated power supply | Grounded field circuit

Safety barrier used: 9002/11-280-186-001

[Go to the quick selection](#)

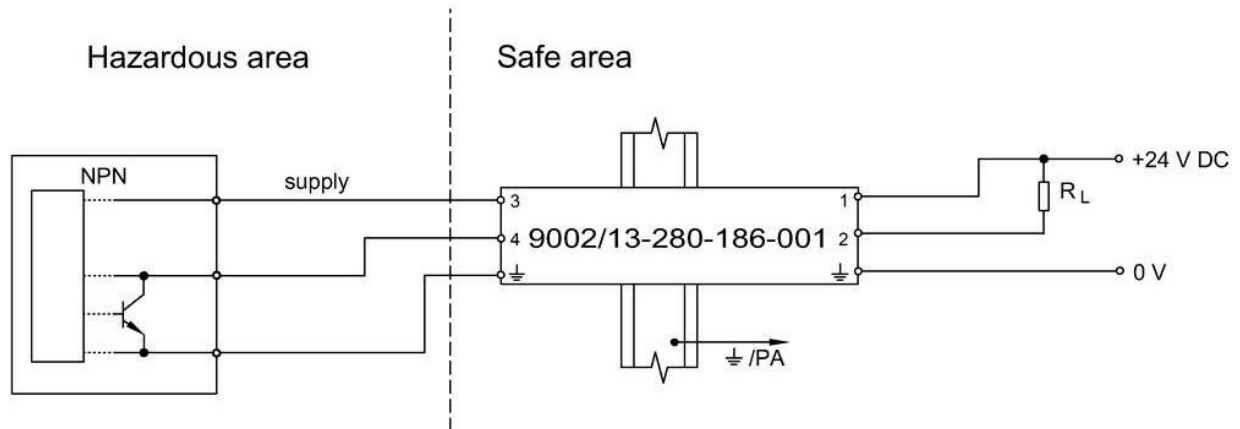

24505E_02

Operating data

Operating voltage	$U_N = +24 \text{ V}$
Maximum resistance of the safety barrier	$R_{\max} = 359 \Omega$
Additional voltage drop	Assumed: Field device: $\Delta U \leq 2 \text{ V}$
Current through the load	Assumed: $I_L = 20 \text{ mA}$
Voltage at the load	$U_L = 24 \text{ V} - (359 \Omega \cdot 20 \text{ mA}) - 2 \text{ V} = 14.82 \text{ V}$
Maximum load (at $I_L = 20 \text{ mA}$)	$L_{\max} = 14.82 \text{ V} / 20 \text{ mA} \approx 741 \Omega$

Safety data

Maximum voltage	$U_o = 28 \text{ V}$		
Maximum current	$I_o = 186 \text{ mA}$		
Maximum power	$P_o = 1300 \text{ mW}$		
Maximum permissible external inductance	L_o	IIC -	IIB 2.8 mH
Maximum permissible external capacitance	C_o	IIC -	IIB 0.551 μF

Application note

With this barrier, all loop voltages must be checked to ensure correct functioning.

Thermocouples and mV transmitters

Ungrounded field circuit

Safety barrier used: 9002/77-093-300-001

[Go to the quick selection](#)

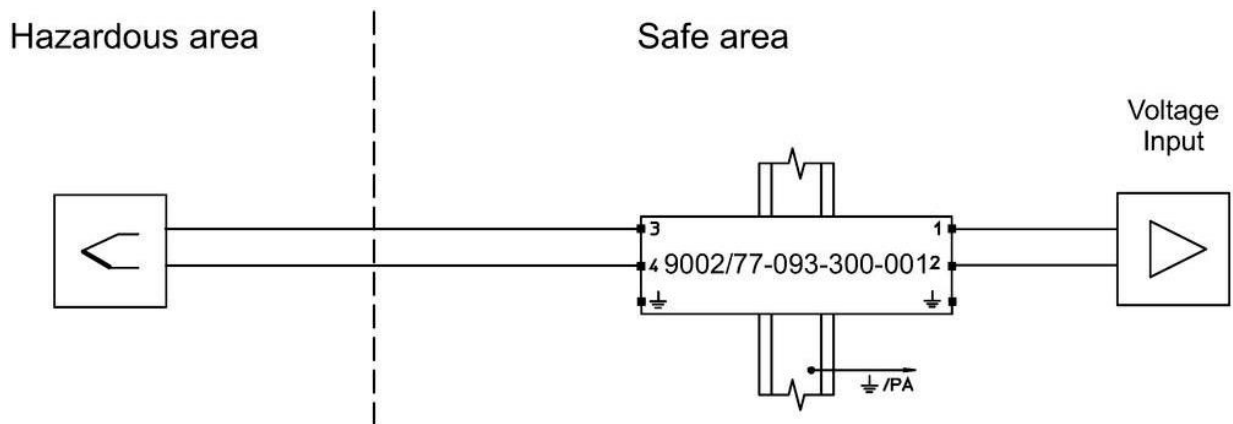

09958E02

Operating data

Maximum series resistance of the safety barrier	$R_{\max} = 2 \times 81.5 \Omega$
Sensor voltage	$U \leq 6 V_{pp}$

Safety data

Maximum voltage	$U_o = 9.3 V$		
Maximum current	$I_o = 300 mA$		
Maximum power	$P_o = 700 mW$		
Maximum permissible external inductance	L_o	IIC 0.2 mH	IIB 1.8 mH
Maximum permissible external capacitance	C_o	IIC 4.1 μF	IIB 31 μF

Application note

Ungrounded thermocouples are recommended for use with safety barriers. Galvanic isolators are recommended if grounded thermocouples are used.

It is recommended that you use a compensating line on both sides of the safety barrier connection. A suitable electrostatic shield should also be provided to discharge any noise in the electrical circuit. The low resistance of this safety barrier makes it possible to connect any type of thermocouple.

Pt100, 2-wire circuit

Pt100 | 2-wire circuit | Ungrounded field circuit

Safety barrier used: 9002/22-032-300-111

⇒ [Go to the quick selection](#)

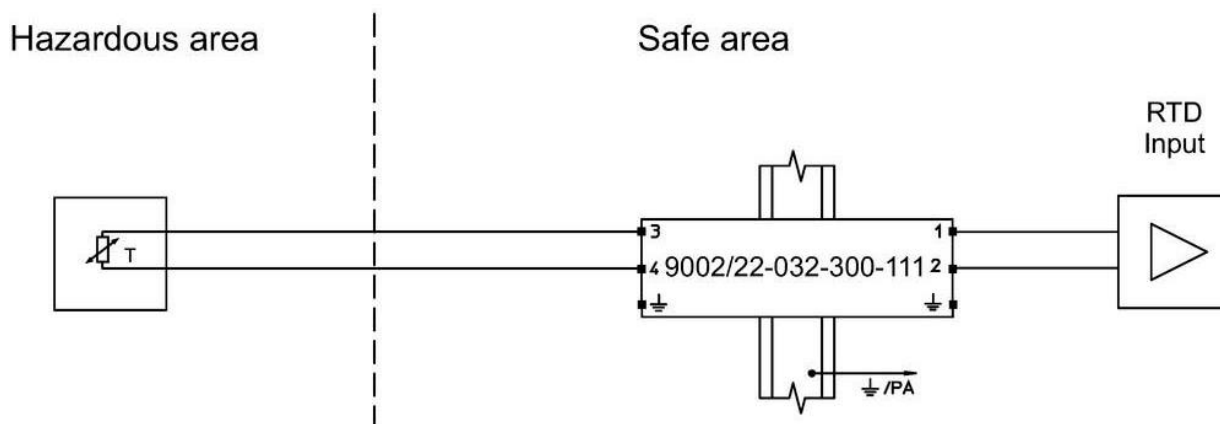

09959E02

Operating data

Operating voltage	$U_N \leq 1.4 \text{ V}$
Series resistance of the safety barrier	$R = 2 \times (20 \Omega \pm 0.1 \Omega)$

Safety data

Maximum voltage	$U_o = 3.2 \text{ V}$		
Maximum current	$I_o = 300 \text{ mA}$		
Maximum power	$P_o = 120 \text{ mW}$		
Maximum permissible external inductance	L_o	IIC 0.2 mH	IIB 1.8 mH
Maximum permissible external capacitance	C_o	IIC 100 μF	IIB 1000 μF

Application note

Although 2-wire RTD circuits are the least accurate when using safety barriers due to the additional resistor of the safety barrier, the aforementioned safety barrier has a precision resistor with a tolerance of $\pm 0.1 \Omega$ to minimise the loss of accuracy. Line compensation must be performed in the evaluation device. Using 3- or 4-wire RTD circuits is recommended, with 4-wire ones being the most accurate.

Pt100, 3-wire circuit

Pt100 | 3-wire circuit | Ungrounded field circuit

Safety barrier used: 9002/22-032-300-111
9001/02-016-150-111

⇒ [Go to the quick selection](#)

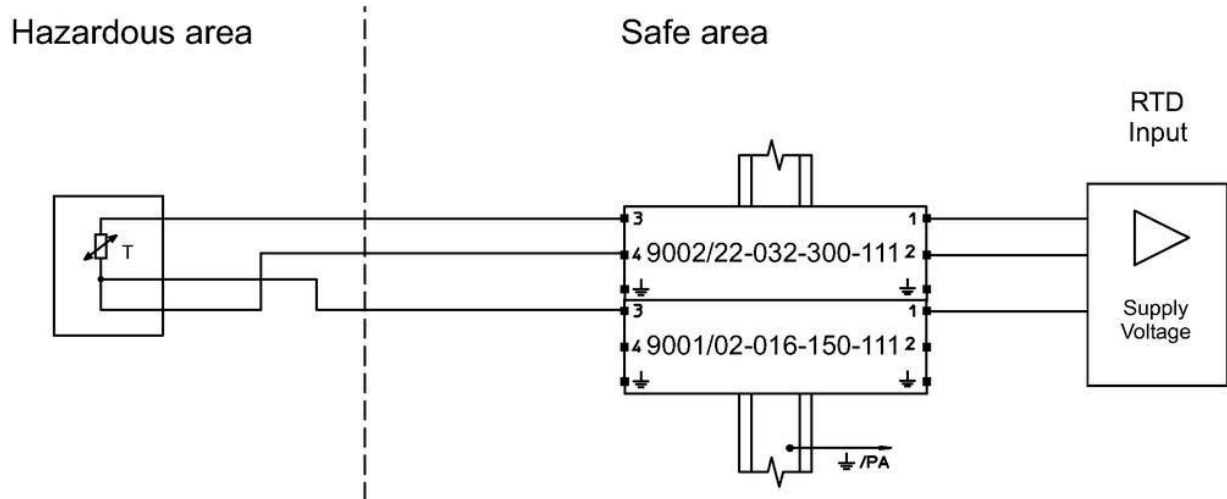

09960E02

Operating data

Operating voltage	$U_N \leq 1.4 \text{ V}$
Series resistance of the safety barrier	$R = 3 \times (20 \Omega \pm 0.1 \Omega)$

Safety data (connecting safety barriers)

Maximum voltage	$U_o = 1.6 \text{ V} + \max. (1.6 \text{ V}; 1.6 \text{ V}) = 3.2 \text{ V}$
Maximum current	$I_o = 300 \text{ mA} + 150 \text{ mA} = 450 \text{ mA}$
Maximum power	$P_o = 120 \text{ mW} + 60 \text{ mW} = 180 \text{ mW}$

According to EN 60079-11:

Maximum permissible external inductance	L_o	IIC	IIB
		0.12 mH	0.5 mH
Maximum permissible external capacitance	C_o	IIC	IIB
		0.100 μF	1000 μF

Application note

This safety barrier has a precision resistor with a tolerance of $\pm 0.1 \Omega$ to limit the loss of accuracy. Line compensation must be performed in the evaluation device. Using 3- or 4-wire RTD circuits is recommended, with 4-wire ones being the most accurate.

Pt100, 4-wire circuit

Pt100 | 4-wire circuit | Ungrounded field circuit

Safety barrier used: 9002/22-032-300-111
9002/77-093-040-001

⇒ [Go to the quick selection](#)

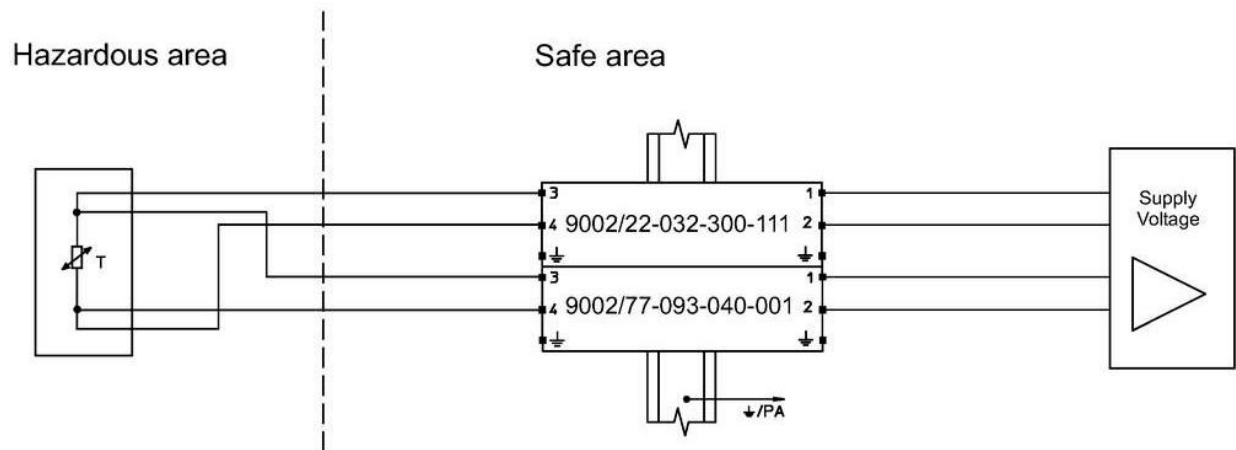

09961E_02

Operating data

Operating voltage	$U_N \leq 1.4 \text{ V}$
Series resistance of the safety barrier	Signal: 9002/22-032-300-111: $R = 2 \times (20 \Omega \pm 0.1 \Omega)$ Sense: 9002/77-093-040-001: $R = 2 \times 545 \Omega$

Safety data (connecting safety barriers)

Maximum voltage	$U_o = 1.6 \text{ V} + 9.3 \text{ V} = 10.9 \text{ V}$
Maximum current	$I_o = 300 \text{ mA} + 40 \text{ mA} = 340 \text{ mA}$
Maximum power	$P_o = 120 \text{ mW} + 90 \text{ mW} = 210 \text{ mW}$

According to EN 60079-11:

Maximum permissible external inductance	L_o	IIC	IIB
		0.28 mH	1.5 mH
Maximum permissible external capacitance	C_o	IIC	IIB
		2.05 μF	14.4 μF

Application note

This safety barrier for the signal has a precision resistor with a tolerance of $\pm 0.1 \Omega$ to limit the loss of accuracy. Line compensation must be performed in the evaluation device. Using 3- or 4-wire RTD circuits is recommended, with 4-wire ones being the most accurate.

Binary input (potential-free contact) with switch

Regulated power supply | Switch (load in the supply line) | Grounded field circuit
 Safety barrier used: 9001/01-280-110-101

[Go to the quick selection](#)

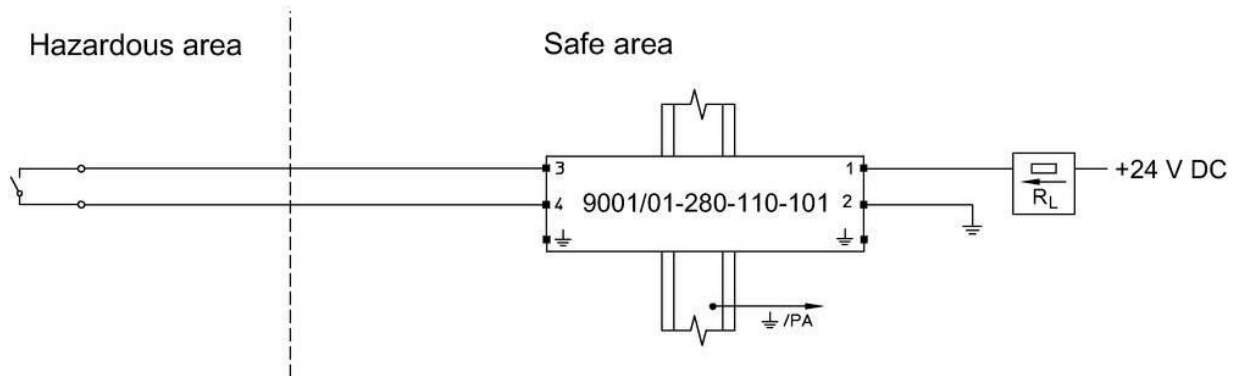

24506E_02

Operating data

Operating voltage	$U_N = + 24 \text{ V}$
Maximum operational current	$I_{\max} = 81 \text{ mA}$
Maximum resistance of the safety barrier	$R_{\max} = 294 \Omega$
Current/voltage at the load resistor R_L	$I_L = 24 \text{ V} / (R_{\max} + R_L)$ $U_L = R_L \cdot I_L$

Current and voltage at the load resistor R_L as a function of the load resistor R_L

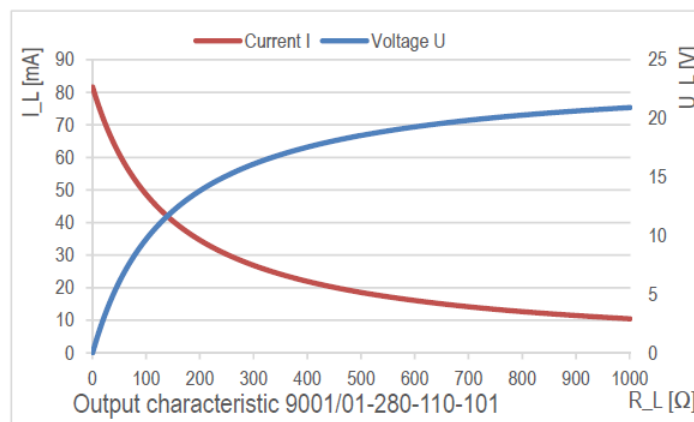

Safety data

Maximum voltage	$U_o = 28 \text{ V}$		
Maximum current	$I_o = 110 \text{ mA}$		
Maximum power	$P_o = 770 \text{ mW}$		
Maximum permissible external inductance	L_o	IIC 1.2 mH	IIB 9 mH
Maximum permissible external capacitance	C_o	IIC 0.083 μF	IIB 0.65 μF

Application note

This safety barrier is ideal for controlling relays.
 A binary input (optocoupler) of an automation device can be operated as a load.

Binary input (potential-free contact) with switch

Regulated power supply | Switch (load in the return line) | Ungrounded field circuit
 Safety barrier used: 9002/13-280-093-001

[Go to the quick selection](#)

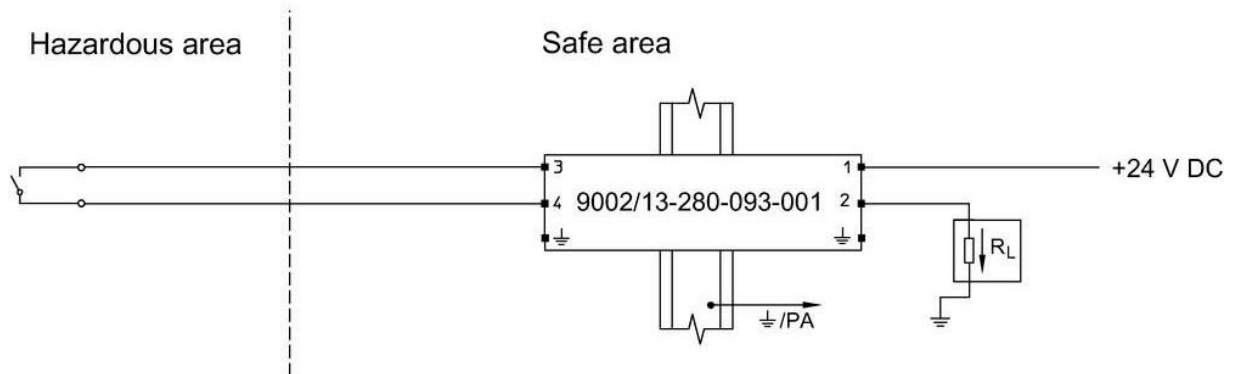

24507E_02

Operating data

Operating voltage	$U_N = +24 \text{ V}$
Maximum operational current	$I_{\max} = 67 \text{ mA}$
Maximum resistance of the safety barrier	$R_{\max} = 359 \Omega$
Additional voltage drop at the diode	$\Delta U = 2 \text{ V}$
Current/voltage at the load resistor R_L	$I_L = (U_N - \Delta U) / (R_{\max} + R_L)$ $U_L = R_L \cdot I_L$

Current and voltage at the load resistor R_L as a function of the load resistor R_L

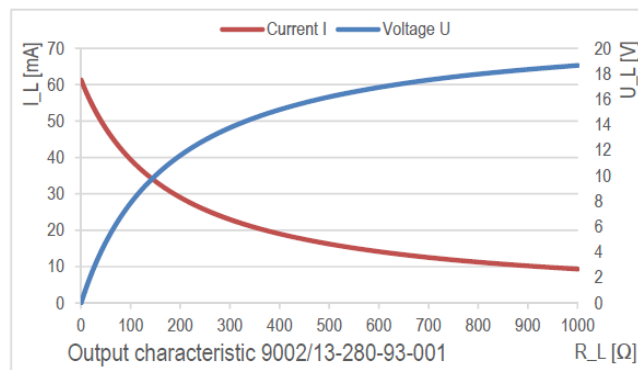

Safety data

Maximum voltage	$U_o = 28 \text{ V}$		
Maximum current	$I_o = 93 \text{ mA}$		
Maximum power	$P_o = 651 \text{ mW}$		
Maximum permissible external inductance	L_o	IIC 2.2 mH	IIB 14 mH
Maximum permissible external capacitance	C_o	IIC 0.083 μF	IIB 0.65 μF

Application note

With the 9002/33-280-000-001, additional contacts can be connected in parallel.

Binary input (potential-free contact) with switch

Unregulated power supply | Switch (load in the return line) | Grounded field circuit
 Safety barrier used: 9001/01-252-060-141

[Go to the quick selection](#)

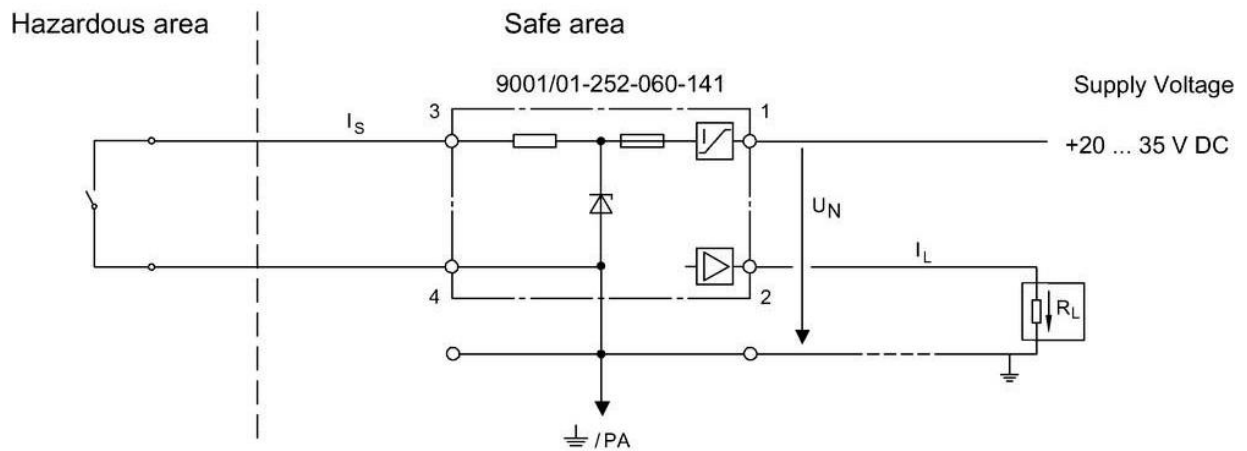

24508E_02

Operating data

Supply voltage $U_N = +20$ to 35 V DC

Switching circuit:

Additional voltage drop of current limiting $\Delta U = 3$ V

No-load output voltage (3 -> 4, $I_N = 0$)
 $U_N \leq 24$ V $U_N > 24$ V
 21 V $< U_S \leq U_N - 3$ V $U_S = 21$ V

Maximum resistance of the safety barrier $R_{max} = 506$ Ω

Switching current $I_S = U_S / R_{max}$

Load circuit:

Limited load current $I_L \leq 40$ mA

Additional voltage drop of current limiting $\Delta U = 3$ V

Voltage at the load $U_L = U_N - 3$ V

Current and voltage at the load resistor R_L as a function of the load resistor R_L (at $U_L = 21$ V)

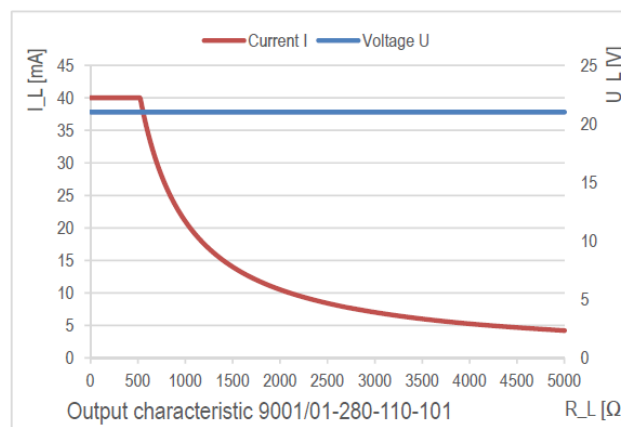

Safety data

Maximum voltage	$U_o = 25.2 \text{ V}$		
Maximum current	$I_o = 60 \text{ mA}$		
Maximum power	$P_o = 378 \text{ mW}$		
Maximum permissible external inductance	L_o	IIC 6.2 mH	IIB 25 mH
Maximum permissible external capacitance	C_o	IIC 0.107 μF	IIB 0.82 μF

Application note

This safety barrier is ideal for controlling relays.

A binary input (optocoupler) of an automation device can be operated as a load.

This safety barrier has a switching function and two electrical circuits: The switching circuit (through the intrinsically safe apparatus or the switch) and the load circuit (through the load). If terminals 3 and 4 are bridged, the safety barrier switches and the load circuit is closed.

The switching circuit is intrinsically safe and is limited by the voltage limiting and the series resistance of the safety barrier.

The load circuit is non-intrinsically safe and is not limited by the series resistance either. Instead, the load current is limited to $I_L \leq 40 \text{ mA}$.

The load circuit is designed as Ex ec and must not lead into Zone 1 or Zone 0.

Load cell (strain gauge) 350 Ω 6 wires + 10 V

350 Ω | 6 wires + 10 V | Ungrounded field circuit

Safety barrier used: 9002/11-130-360-001
 9002/11-120-024-001
 9002/11-120-024-001

⇒ [Go to the quick selection](#)

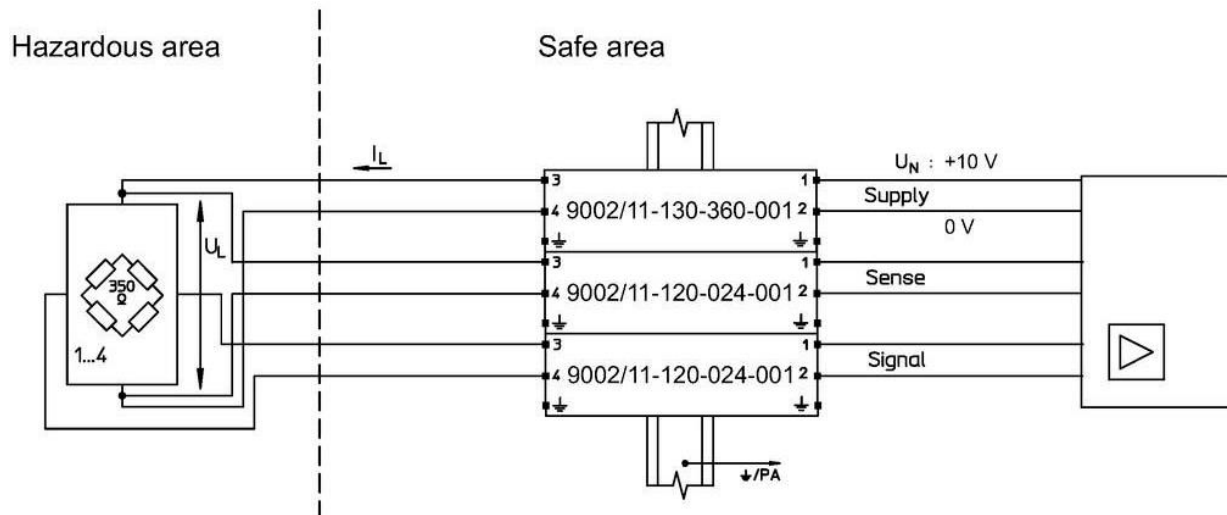

11010E_02

Operating data

Operating voltage $U_N = 10\text{ V}$
 Maximum resistance of the safety barrier $R_{\max} = 2 * 52\ \Omega = 104\ \Omega$

Number of load cells connected in parallel	350 Ω		
	$R_{\text{total}}\ (\Omega)$	$U_L\ (\text{V})$	$I_L\ (\text{mA})$
1	454.0	7.7	22.0
2	279.0	6.3	35.8
3	220.7	5.3	45.3
4	191.5	4.6	52.2

Safety data

Maximum voltage $U_o = \max. (13\text{ V}; 12\text{ V}; 12\text{ V}) = 13\text{ V}$
 Maximum current $I_o = 360\text{ mA} + 24\text{ mA} + 24\text{ mA} = 408\text{ mA}$
 Maximum power $P_o = 1060\text{ mW} + 70\text{ mW} + 70\text{ mW} = 1200\text{ mW}$

According to EN 60079-11:

Maximum permissible external inductance	L_o	IIC	IIB
		0.18 mH	1.45 mH
Maximum permissible external capacitance	C_o	IIC	IIB
		0.270 μF	1.64 μF

Application note

For 4-wire circuits (without sense), there is no need for the corresponding safety barrier. The operating data remains unchanged. The safety-relevant maximum current is reduced to $I_o = 384\text{ mA}$, the maximum power to $P_o = 1130\text{ mW}$.

Load cell (strain gauge) 350 Ω or 700 Ω 6 wires + 16 V

350 Ω or 700 Ω | 6 wires + 16 V | Ungrounded field circuit

⇒ [Go to the quick selection](#)

Safety barrier used:
 9002/13-199-225-001
 9002/11-199-030-001
 9002/11-199-030-001

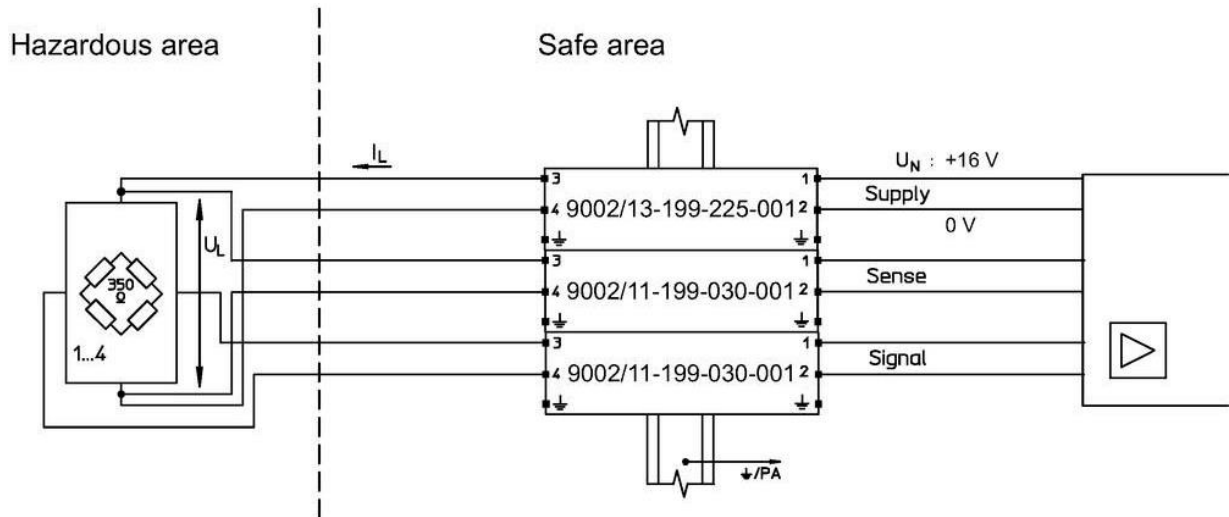

09963E02

Operating data

Operating voltage $U_N = 16 \text{ V}$
 Additional voltage drop at the diode $\Delta U = 2 \text{ V}$
 Maximum resistance of the safety barrier $R_{\max} = 109 \Omega$

Number of load cells connected in parallel	350 Ω			700 Ω		
	$R_{\text{total}} (\Omega)$	$U_L (\text{V})$	$I_L (\text{mA})$	$R_{\text{total}} (\Omega)$	$U_L (\text{V})$	$I_L (\text{mA})$
1	459.0	10.7	30.5	809.0	12.1	17.3
2	284.0	8.6	49.3	459.0	10.7	30.5
3	225.7	7.2	62.0	342.3	9.5	40.9
4	196.5	6.2	71.3	284.0	8.6	49.3

Safety data

Maximum voltage $U_o = \max. (19.9 \text{ V}; 19.9 \text{ V}; 19.9 \text{ V}) = 19.9 \text{ V}$
 Maximum current $I_o = 225 \text{ mA} + 30 \text{ mA} + 30 \text{ mA} = 285 \text{ mA}$
 Maximum power $P_o = 1120 \text{ mW} + 150 \text{ mW} + 150 \text{ mW} = 1420 \text{ mW}$

According to EN 60079-11:





Maximum permissible external inductance	L_o	IIC 0.2 mH	IIB 1.8 mH
Maximum permissible external capacitance	C_o	IIC 0.223 μF	IIB 1.42 μF

Application note

For 4-wire circuits (without sense), there is no need for the corresponding safety barrier. The operating data remains unchanged. The safety-relevant maximum current is reduced to $I_o = 255 \text{ mA}$, the maximum power to $P_o = 1270 \text{ mW}$.

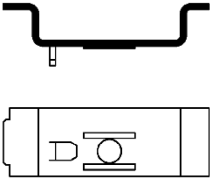
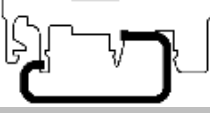
7 Appendix

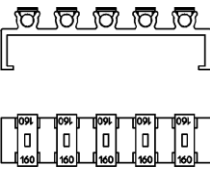
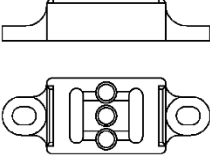
7.1 Accessories and spare parts

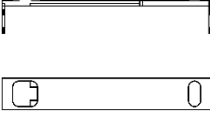
Figure	Description	Item no.	Weight kg
<p>Adaptor</p> 	The adaptor enables a Series 900x safety barrier to be installed on a mounting plate from a previous series.	158826	0.006
<p>Clamping base made of moulded material</p> 	Enables the safety barrier to be mounted on a G-rail.	165283	0.004
<p>Terminal block</p> 	Phoenix Contact terminal block UT 4- PE	113057	0.012
	Phoenix Contact terminal block UT 6- PE	113058	0.022
<p>Fuse holder</p> 	Fuse holder is clipped onto the side of a safety barrier and can be equipped with up to five back-up fuses (spare).	158834	0.020
<p>Insulation and fastening material</p> 	Suitable for the NS 35/15 DIN rail, makes it possible to install the DIN rail such that it is electrically isolated from the mounting plate.	158828	0.023
<p>Back-up fuse</p> 	For all Series 9001, 9002 and 9004 safety barriers Packaging unit: 5 pieces	158964	0.008
<p>Label carrier</p> 	Transparent cover for the label	158977	0.002