

# Applications of low-voltage systems

Light circuit distribut. board With miniature circuit breaker



8146/5-ExV-04-24L16C1P-T Art. No. 137130



- Standard variants with short delivery times, customer-specific options possible
- With miniature circuit breaker, tripping characteristic C
- With residual current circuit breaker with overcurrent release, tripping characteristic C
- Nominal currents of 10, 16, 20 and 25 A

MY R. STAHL 8146D



R. STAHL Series 8146 lighting and heating circuit distribution boards are modular and are therefore available in a large number of standard variants which are ready for rapid delivery. Custom-specific options are also possible. The moulded case circuit breakers are installed beneath a hinged inspection glass and can be actuated from the outside, even when live. The switching position is visible at all times.

## Technical Data

### Explosion Protection

Application range (zones)	1, 2, 21, 22
IECEX gas certificate	IECEX PTB 06.0090
IECEX gas explosion protection	Ex db eb IIC T6 Gb
IECEX dust certificate	IECEX PTB 06.0090
IECEX dust explosion protection	Ex tb IIIC T80 °C Db
ATEX gas certificate	PTB 01 ATEX 1024
ATEX gas explosion protection	Ex II 2 G Ex db eb IIC T6 Gb
ATEX dust certificate	PTB 01 ATEX 1024
ATEX dust explosion protection	Ex II 2 D Ex tb IIIC T80 °C Db
Certificates	ATEX (PTB), Canada (FM), China (NEPSI), IECEX (PTB), India (PESO), Korea (KGS), Taiwan (ITRI), USA (FM)
Declaration of conformity	ATEX (EUK), China (CCC)
Explosion protection note	Product label may vary. Series devices are labelled with ATEX and IECEX.

### Electrical Data

Rated operational voltage AC	230 ... 400 V
Rated operational current	80 A (T6)
Layout No.	04
Frequency range	50 – 60 Hz
Notes	Depending on the terminal type and the explosion-protected components used

### Ambient Conditions

Ambient temperature	-20 °C ... +40 °C
---------------------	-------------------

### Mechanical Data

Degree of protection (IP)	IP66
Degree of protection (IP) (IEC 60529)	IP66
Enclosure material	Polyester resin, Glass fibre reinforced
Enclosure colour	Grey

# Applications of low-voltage systems

Light circuit distribut. board With miniature circuit breaker



8146/5-ExV-04-24L16C1P-T Art. No. 137130

## Mechanical Data

Flame retardant acc.	IEC/EN 60695, UL 94, ASTM D635
Max. finely stranded connection terminals	35 mm <sup>2</sup>
Width	1236 mm
Height	684 mm
Depth	240 mm
Impact strength (IEC 60079)	7 J
Weight	70 kg
Weight	154.32 lb

## Components

Locking device present	Yes
Built-in unit 2	24 x Miniature circuit breaker 1-pole 16 A/C/6 kA
Entry 1	1 x 8161/7-M50-3516
Entry 2	24 x 8161/7-M25-1707
Entry 3	1 x 8161/7-M16-0902
Type of terminals PE 1	1 x Phoenix UT 2-conductor, 35 mm <sup>2</sup> , green-yellow
Earth rail	12 x 10 mm <sup>2</sup> (3x)

## Technical Drawings – Subject to Alterations

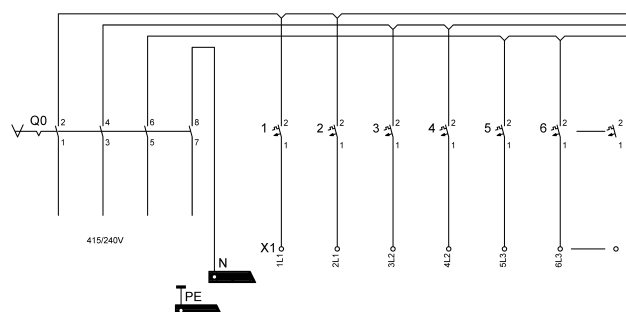

Circuit diagram 8146/5-ExV-.....1P-T

## Dimensional Drawings (All Dimensions in mm [inches]) – Subject to Alterations

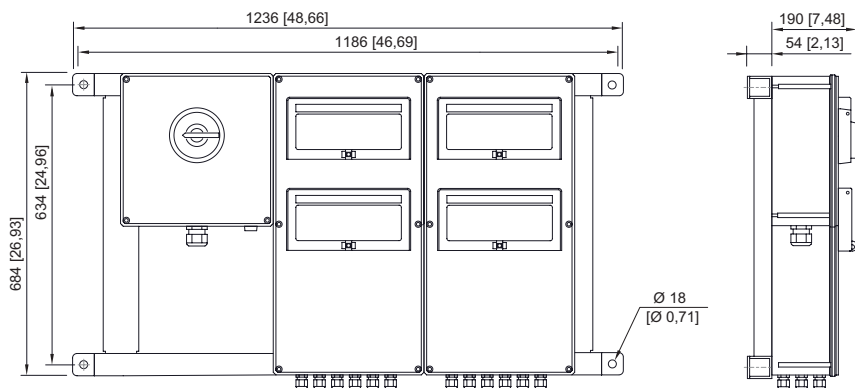

Layout 04

We reserve the right to make alterations to the technical data, dimensions, weights, designs and products available without notice. The illustrations cannot be considered binding.