



- For connection of 4, 8 or 12 fieldbus devices in Zone 2
- Ex ec or ic spurs
- Operation on the high-power trunk
- Reduced start-up current thanks to power management and short-circuit limiting with disconnection

### MY R. STAHL 9410A



The Ex ec field device coupler series 9410 for Zone 2 are used for reaction-free connection of up to 12 FOUNDATION Fieldbus H1 or PROFIBUS PA field devices to the high-power trunk. The spurs with ec or ic type of protection can be used for fieldbus devices in Zones 2 (ic, ec) and 1 (d, q, m) and are short-circuit limited.

The integrated power management minimises start-up and short-circuit currents.

## Technical Data

### Explosion Protection

Application range (zones)	2
Ex interface zone	1, 2
IECEX gas certificate	IECEX BVS 11.0015X
IECEX gas explosion protection	Ex ec [ic] IIC T4 Gc
ATEX gas certificate	BVS 11 ATEX E 031 X
ATEX gas explosion protection	Ⓔ II 3 G Ex ec [ic] IIC T4 Gc
FMus certificate	3026646
cFM certificate	3026646C
Marking cFMus	NI, Class I, Div. 2, Groups A,B,C,D; T4, ANI Class I,II,III, Div. 2, Groups A,B,C,D,E,F,G; Class I, Zone 2, AEx/Ex nA [ic] IIC T4 T4 at Ta = 75°C See Doc. 9410 6 031 001 1
Certificates	ATEX (BVS), Canada (FM), IECEX (BVS), International (FF), USA (FM)
Declaration of conformity	ATEX (EUK)

### Safety Data

Max. voltage $U_o$ note	$U_o$ of the connected fieldbus power supply
Max. current $I_o$	54 mA
Max. power $P_o$ note	$P_o = 1.35 \text{ W}$ (reduces when $U_i < 25 \text{ V}$ corresponding to $P = U * I$ )
Max. permissible external capacity $C_o$ for IIC	80 nF
Max. permissible external inductance $L_o$ for IIC	0.27 mH
Internal capacitance	110 pF
Internal capacitance	110 nF
Internal inductance	0 mH

#### Electrical Data

Max. number of field devices per segment	16 (FF H1) 32 (Profibus PA)
Data transmission trunk and spurs	Passive No repeater function
Max. number of field device couplers	4 per trunk
Power Management	If the voltage on the trunk exceeds 9 V, the spurs are switched on consecutively in order to avoid a high start-up current through the field devices. If a spur short circuit is detected, the affected spur is disconnected until the short circuit is removed. The trunk is loaded with max. one short-circuit current, regardless of how many spurs are short-circuited. This minimises the current drawn by the trunk and the power dissipation under all operating conditions.
Fieldbus termination	The field device couplers in the 9410 series have no terminator installed. An external terminator from the 9418 series must be connected in the trunk B connection.

#### Auxiliary Power

Max. power dissipation	1.2 W
Auxiliary power	Not required; the field device coupler is supplied from the trunk.

#### Galvanic Isolation

Galvanic separation spur/trunk	No galvanic separation
Galvanic separation spur/spur	No galvanic separation

#### Input

Trunk connections	2 (IN/OUT) Bridged internally
Trunk version	High power trunk/Ex ec
Min. input voltage	10.7 V according to FF-846
Input voltage note	This ensures that the output voltage (spurs) is 9.3 V under full load.
Voltage range	9 – 32 V
Input undervoltage monitoring	< 9 V, spurs de-energised
Max. trunk voltage IN/OUT	≤ 2 A
Max. trunk voltage drop IN/OUT	≤ 10 mV at 2 A/25 °C
Trunk polarity reversal protection	Yes
Trunk earthing	At "S" terminal
Max. current consumption	0 mA per spur: 25 mA 20 mA per spur: 185 mA 41 mA per spur: 353 mA 7 spurs with 41 mA each, 1 spur per short circuit: 362 mA Short circuit all spurs: 75 mA

#### Output

Spurs Note	Spurs ic only in connection with a voltage-limited fieldbus power supply (e.g. R. STAHL type 9412/01).
Max. number of field devices per spur	1
Max. cable length	120 m
Max. continuous output current DC	41 mA
Max. voltage drop trunk/spur	≤ 1 V
Output max. short-circuit current	50 mA
Spurs earthing	At "S" terminal

#### Field Device Interface

Spurs version	Ex ec / ic
---------------	------------

#### Field Device Interface

Spurs connections	8
Spurs connection type	Detachable screw terminal with fuse

#### Device Specific Data

Trunk LED operating conditions	"PWR" LED, green
Spurs operating condition LED	"SPUR 1" to "SPUR 8" LED, red
LED error indication	"SPUR 1" to "SPUR 8" LED Red, off
Error detection	Short circuit $\geq 42$ to 50 mA
Short circuit indication	"SPUR 1" to " SPUR 8" LED Red, lights up
Note	The R. STAHL "Fieldbus wizard" tool (r-stahl.com) must be used for correct project engineering.

#### Ambient Conditions

Ambient temperature	-40 °C ... 75 °C
Ambient temperature	-40°F ... +167°F
Storage temperature	-40 °C ... 80 °C
Storage temperature	-40°F ... +176°F
Max. operating altitude	< 2000 m
Max. operating altitude	2000 m
Max. operating altitude, ft	< 6562 ft
Max. relative humidity	95% (without condensation)
Max. relative humidity	95 %
Electromagnetic compatibility	Tested to the following standards and regulations: EN 61326 (IEC/EN 61000-4-1 to 61000-4-6 and 61000-4-11; EN 55022 class B), NAMUR NE21

#### Mechanical Data

Field enclosure	without
Trunk connection type	detachable screw terminal with fuse
Connection terminals	3-pole (+, -, shield)
Rigid single-wire connection	Trunk 0.2 to 2.5 mm <sup>2</sup> Spurs 0.2 to 2.5 mm <sup>2</sup>
Flexible single-wire connection	Trunk 0.2 to 2.5 mm <sup>2</sup> Spurs 0.2 to 2.5 mm <sup>2</sup>
Flexible single-wire connection with sleeve	Trunk 0.25 to 2.5 mm <sup>2</sup> Spurs 0.25 to 2.5 mm <sup>2</sup>
Degree of protection (IP) (IEC 60529)	IP30 enclosure IP30 Ex e terminals
Module enclosure	PVC, PA
Fire resistance (UL 94)	V0
Pollutant class	Corresponds to G3
Width	154 mm
Width, inches	6.06 in
Height	94 mm
Height in inches	3.7 in
Depth	64 mm
Depth in inches	2.52 in

# Network technology

ISbus fieldbus technology Field device coupler, 8 spurs

for Zone 2 Ex ec

9410/34-330-40 Art. No. 207905



## Mechanical Data

Mounting depth in inches	3.7 in
Spurs oper. status LED desig.	SPUR 1 ... SPUR 8
Weight	883 g

## Mounting / Installation

Mounting type	on NS 35/15 DIN rail (DIN EN 60715)
Mounting orientation	Horizontal Vertical

## Components

Trunk oper. status LED desig.	PWR
Trunk op. status LED colour	green

## Technical Drawings – Subject to Alterations

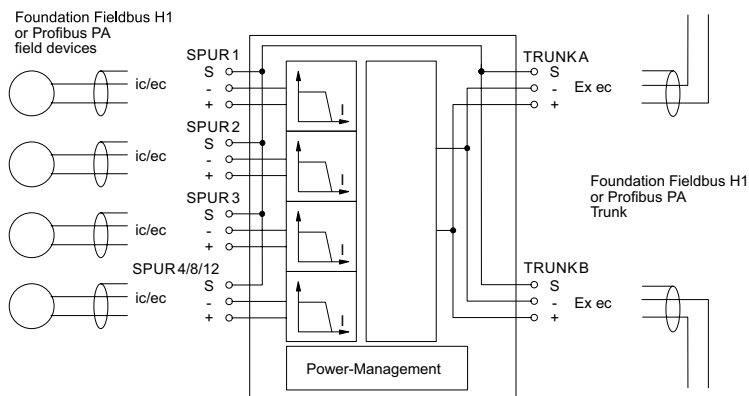

## Dimensional Drawings (All Dimensions in mm [inches]) – Subject to Alterations

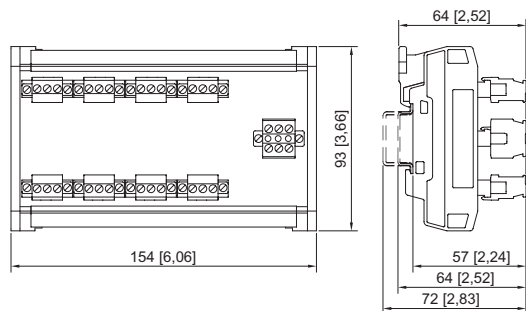

Field device coupler, 8 spurs, without enclosure

## Accessories

### Cable for FOUNDATION Fieldbus, PROFIBUS PA

Art. No.



Cable type: O2YS(St+Ce)Y-fl  
 Colour (sheath): Orange  
 Application area: Universal use  
 FISCO, UL listed, sunlight-resistant, oil-resistant, flame retardant

169329

## Network technology

ISbus fieldbus technology Field device coupler, 8 spurs

for Zone 2 Ex ec

9410/34-330-40 Art. No. 207905



### End-of-line resistor

Art. No.



"Ex m" fieldbus terminator

168062

### Fieldbus power supply

Art. No.



For supplying a non-intrinsically safe trunk. Advanced version (with integrated diagnostics and alarm).

200589

### Fieldbus wizard engineering tool

Art. No.

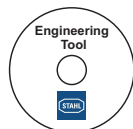

Engineering tool for project engineering for Foundation Fieldbus or PROFIBUS PA fieldbus segments  
Download from [r-stahl.com](http://r-stahl.com)

We reserve the right to make alterations to the technical data, dimensions, weights, designs and products available without notice. The illustrations cannot be considered binding.