

Isolator Barriers

Ex i power supply

Ex i field circuit ISpac

9143/10-124-150-10s Art. No. 159823



- For the intrinsically safe supply of power to three- or four-conductor transmitters, solenoid valves, light barriers and controllers
- Stable, adjustable output voltage
- Extensive portfolio with either DC or AC auxiliary power

MY R. STAHL 9143A



The 9143 series compact I.S. power supply is used for the intrinsically safe supply of power to field devices, e.g. three- or four-conductor transmitters, solenoid valves, light barriers and controllers. It delivers stable, adjustable output voltage via intrinsically safe outputs.

Technical Data

Explosion Protection

Application range (zones)	2
Ex interface zone	1, 2, 21, 22
IECEX gas certificate	IECEX BVS 12.0009 X
IECEX gas explosion protection	Ex nA [ib Gb] IIC/IIB T4 Gc
IECEX dust certificate	IECEX BVS 12.0009 X
IECEX dust explosion protection	[Ex ib Db] IIIC
IECEX firedamp certificate	IECEX BVS 12.0009 X
IECEX firedamp protection	[Ex ib Mb] I
ATEX gas certificate	BVS 05 ATEX E 152 X
ATEX gas explosion protection	⊕ II 3 (2) G Ex nA [ib Gb] IIC/IIB T4 Gc
ATEX dust certificate	BVS 05 ATEX E 152 X
ATEX dust explosion protection	⊕ II (2) D [Ex ib Db] IIIC
ATEX firedamp certificate	BVS 05 ATEX E 152 X
ATEX firedamp protection	⊕ I (M2) [Ex ib Mb] I
cCSAus certificate	1570027
Marking cCSAus	Class I, Zone 2, AEx Ex/nA [ib Gb] IIB 1 Gc Class I, Zone 1, Ex nA [ib Gb] Group IIB T4 Gc See doc. 91 436 01 32 2
Certificates	Canada / USA (CSA), Korea (KGS)
Ship approval	CCS, EU RO MR (DNV)
Declaration of conformity	ATEX (EUK)
Installation	In Zone 2 and safe areas
Further information	see respective certificate and operating instructions

Safety Data

Max. voltage U_o/V_{oc}	12.4 V
Max. current I_o/I_{sc}	150 mA
Max. power P_o	1.86 W

Isolator Barriers

Ex i power supply

Ex i field circuit ISpac

9143/10-124-150-10s Art. No. 159823



Safety Data

Max. permissible external capacitance C_e/C_a for IIC	1.24 μ F	
Max. permissible external inductance L_e/L_a for IIC	0.17 mH	
Max. permissible external capacitance C_e/C_a for IIB	7.9 μ F	
Max. permissible external inductance L_e/L_a for IIB	2.08 mH	
Max. permissible ext. capac. I	34 μ F	
Max. permissible external inductance L_e for I	20 mH	
Internal capacitance	Negligible	
Internal inductance	Negligible	
Safety-related max. voltage	253 V	
Intrinsically safe limiting values inductance L_o /capacitance C_o	Jointly connectable inductance L_o /capacitance C_o	
IIC	L_o [mH]	0.100 mH
	C_o [μ F]	1.100 μ F
IIB	L_o [mH]	1 mH
	C_o [μ F]	2.900 μ F
I	L_o [mH]	0.500 mH
	C_o [μ F]	7 μ F

Functional Safety

Further information	See test report
---------------------	-----------------

Electrical Data

Type of signal	Ex i power supply
----------------	-------------------

Auxiliary Power

Auxiliary power	24 V AC / DC
Min. nominal DC voltage	18 V
Max. nominal DC voltage	35 V
Auxiliary power voltage range	20 ... 28 V AC, 18 ... 35 V DC
Auxiliary power frequency range AC	48 – 62 Hz
Auxiliary power consumption	3.3 W
Polarity reversal protection	Yes (DC)
Auxiliary power indication	Green LED

Galvanic Isolation

Test voltage	Acc. to IEC EN 60079-11
Output to power supply	1.5 kV

Output

Min. nominal voltage output	9.5 V
Max. nominal voltage output	11.8 V
Max. nominal current I_n output	130 mA
Current limiting	If the max. nominal current is reached, the output voltage is linearly regulated down to 0 V.

Ambient Conditions

Ambient temperature $^{\circ}$ C	-20 $^{\circ}$ C ... +65 $^{\circ}$ C (Single device) -20 $^{\circ}$ C ... +60 $^{\circ}$ C (Group assembly)
----------------------------------	---

Isolator Barriers

Ex i power supply

Ex i field circuit ISpac

9143/10-124-150-10s Art. No. 159823



Ambient Conditions

Ambient temperature °F	-4°F ... +158°F (Single device) -4°F ... +140°F (Group assembly)
Note	Installation conditions influence the ambient temperature. Please observe the "Cabinet installation guide".
Storage temperature °C	-40 °C ... +80 °C
Storage temperature °F	-40°F ... +176°F
Max. relative humidity	< 85% at Ta > 40 °C
Use at the height of	< 2000 m
Electromagnetic compatibility	Tested to the following standards and regulations: EN 61326-1 For use in industrial areas; NAMUR NE 21

Mechanical Data

Degree of protection (IP)	IP30
Degree of protection (IP) terminals	IP20
Fire resistance (UL 94)	V0
Enclosure material	PA 6.6
Min. rigid conductor cross section	0.2 mm ²
Max. rigid conductor cross section	2.5 mm ²
Min. flexible conductor cross section	0.2 mm ²
Max. flexible conductor cross section	2.5 mm ²
Width	35.2 mm
Width, inches	1.39 in
Height	114.5 mm
Height in inches	4.51 in
Length	108 mm
Length in inches	4.25 in
Weight	190 g

Mounting / Installation

Mounting type	DIN rail (NS35/15, NS35/7.5)
Grid dimension	35.2 mm
Mounting orientation	Horizontal Vertical
Connection type	Screw terminal
Connection cross-section AWG	24 ... 14

Technical Drawings – Subject to Alterations

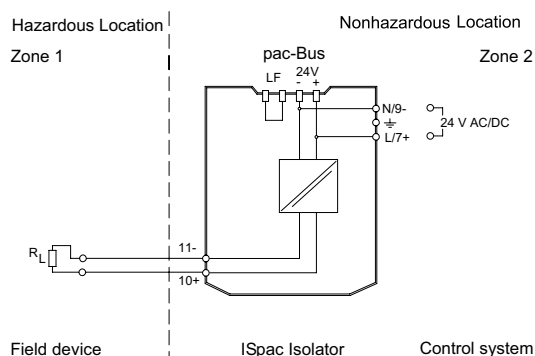

Connection diagram 9143/.....-10.

Isolator Barriers

Ex i power supply

Ex i field circuit ISpac

9143/10-124-150-10s Art. No. 159823



Dimensional Drawings (All Dimensions in mm [inches]) – Subject to Alterations

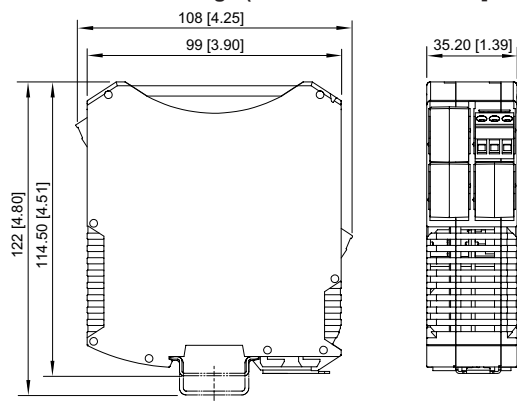

ISpac Series 9185, 9192 with screw terminal

We reserve the right to make alterations to the technical data, dimensions, weights, designs and products available without notice. The illustrations cannot be considered binding.