

Isolator Barriers

Frequency transmitter

Ex i field circuit

9146/20-11-11k Art. No. 159887



- Compact Ex i frequency transmitter for monitoring rotational speed in hazardous areas
- Limit value analysis + frequency-current conversion + pulse divider function over a width of just 17.6 mm
- Parameterization made easy by "ISpac Wizard" software

MY R. STAHL 9146A



9146 series Ex i- frequency transmitters monitor the speed of rotating parts on one or two channels, e.g. the speed of fans or centrifuges. The frequency measured at the intrinsically safe input (between 0.001 Hz and 20 kHz) is issued as a unit signal (0/4 mA to 20 mA) or processed by a frequency divider. In single-channel devices, these frequency transmitters check whether speeds have exceeded or fallen below the limit values.

Technical Data

Explosion Protection

Application range (zones)	2
Ex interface zone	0, 1, 2, 20, 21, 22
IECEX gas certificate	IECEX BVS 13.0095 X
IECEX gas explosion protection	Ex ec nC [ia Ga] IIC T4 Gc
IECEX dust certificate	IECEX BVS 13.0095 X
IECEX dust explosion protection	[Ex ia Da] IIIC
IECEX firedamp certificate	IECEX BVS 13.0095 X
IECEX firedamp protection	[Ex ia Ma] I
ATEX gas certificate	BVS 05 ATEX E 0171 X
ATEX gas explosion protection	⊕ II 3 (1) G Ex ec nC [ia Ga] IIC T4 Gc
ATEX dust certificate	BVS 05 ATEX E 0171 X
ATEX dust explosion protection	⊕ II (1) D [Ex ia Da] IIIC
ATEX firedamp certificate	BVS 05 ATEX E 0171 X
ATEX firedamp protection	⊕ I (M1) [Ex ia Ma] I
FMus certificate	FM16US0122X
cFM certificate	FM16CA0067X
Marking cFMus	Class I, Div. 2, Groups A,B,C,D; Class I, Zone 2, AEx/Ex nA nC Group IIC AIS Class I,II,III, Div. 1, Groups A,B,C,D,E,F,G; Class I, Zone 0, [AEx ia]/[Ex ia] IIC T4 at Ta = 70°C See Doc. 9146 6 031 001 1
Certificates	ATEX (BVS), Canada (FM), IECEX (BVS), India (PESO), USA (FM)
Ship approval	CCS, EU RO MR (DNV)
Declaration of Conformity	ATEX (EUK)

Safety Data

Max. voltage U_o/V_{oc}	10.5 V
---------------------------	--------

Isolator Barriers

Frequency transmitter

Ex i field circuit

9146/20-11-11k Art. No. 159887



Safety Data

Max. current I_o/I_{sc}	23.4 mA				
Max. power P_o	61.4 mW				
Max. permissible external capacity C_o for I	95 μ F				
Max. permissible external inductance L_o for I	600 mH				
Max. permissible external capacitance C_o/C_a for IIC	2.41 μ F				
Max. permissible external capacitance C_o/C_a for IIB	16.8 μ F				
Max. permissible external capa.IIA	75 μ F				
Max. permissible external inductance L_o/L_a for IIC	63 mH				
Max. permissible external inductance L_o/L_a for IIB	230 mH				
Max. permissible external inductance L_o for IIA	450 mH				
Max. permissible external capacity C_o for IIIC	16.8 μ F				
Max. permissible external inductance L_o for IIIC	230 mH				
Internal capacitance	Negligible				
Internal inductance	Negligible				
Safety-related max. voltage	253 V				
Intrinsically safe limiting values inductance L_o /capacitance C_o	Jointly connectable inductance L_o /capacitance C_o				
IIC	L_o [mH]	20 mH	5 mH	1 mH	0.200 mH
	C_o [μ F]	0.490 μ F	0.670 μ F	0.960 μ F	1.400 μ F
IIB	L_o [mH]	100 mH	20 mH	2 mH	0.500 mH
	C_o [μ F]	1.900 μ F			
IIA	L_o [mH]	100 mH	10 mH	1 mH	0.100 mH
	C_o [μ F]	2.900 μ F	4.500 μ F	7.300 μ F	14 μ F
IIIC	L_o [mH]	100 mH	20 mH	2 mH	0.500 mH
	C_o [μ F]	1.900 μ F	2.700 μ F	4.500 μ F	6.400 μ F
I	L_o [mH]	100 mH	10 mH	2 mH	0.100 mH
	C_o [μ F]	4 μ F	5.700 μ F	7.800 μ F	17 μ F

Electrical Data

Number of channels	2
LFD relay	Yes
Parameterisation	With parameterising set 9199/20-02

Auxiliary Power

Auxiliary power	24 V DC
Auxiliary power voltage range	18 to 31.2 V
Voltage range residual ripple	$\leq 3,6 V_{SS}$
Nominal current	75 mA
Power consumption	1.8 W
Max. power dissipation	1.5 W

Isolator Barriers

Frequency transmitter

Ex i field circuit

9146/20-11-11k Art. No. 159887



Auxiliary Power

Polarity reversal protection	Yes
Undervoltage monitoring	Yes
Operation indication	Green "PWR" LED

Galvanic Isolation

Test voltage as per standard	IEC EN 60079-11
Ex i input to output	1.5 kV AC
Ex i input to auxiliary power	1.5 kV AC
Ex i input to fault message contact	1.5 kV AC
Test voltage as per standard	EN 50178
Output to auxiliary power	350 V AC
Output to output	350 V AC
Fault message contact to auxiliary power	350 V AC
Fault message contact to output	350 V AC

Input

Input signal	As per EN 60947-5-6 (NAMUR)
Input current for ON	≥ 2.1 mA
Input current for OFF	≤ 1.2 mA
Hysteresis	Approx. 0.2 mA
Input internal resistance R_i	1000 Ω
Input for open-circuit voltage U_a	8,5 V
Short-circuit current	≤ 8.5 mA
Input frequency	0.0010-20000 Hz
Input for centre resolution note	< 0.1 % of measuring range
Pulse length/pause	25 μ s

Output

Output per channel	0/4 to 20 mA
Output signal	0/4 to 20 mA
Function range output	0.0-20.5 mA
Load resistance R_L	0 ... 600 Ω
Average measurement fault	$\leq 0,1\%$
Temperature influence	$\leq 0,05\%$ / 10 K
Operating modes	Counter, period measurement, variable gate time
Limit contact (per channel)	without
Pulse output	without
Fault message contact switching capacity	30 V / 100 mA
Wire breakage error detection input	$I_E < 0.05$ to 0.35 mA
LF switch user adjustment	Activated/deactivated
Indication of line fault	Red "LF" LED
Deviations / error note	Information in % of the measuring range (20 mA) at $U_N, 23$ °C
Short circuit error detection input	$R_E < 100$ to 360 ohm
Behaviour of the output at line fault	configurable
Behaviour of the output at line fault note	with deactivated line fault: Short circuit: 3.8 mA, wire breakage: 20.5 mA
Line fault and loss of power signalization	- Contact (30 V/100 mA), closed against earth in case of error - pac-Bus, potential-free contact (30 V/100 mA)

Isolator Barriers

Frequency transmitter

Ex i field circuit

9146/20-11-11k Art. No. 159887



Ambient Conditions

Ambient temperature °C	-40 °C ... +70 °C (Single device) -40 °C ... +60 °C (Group assembly)
Ambient temperature °F	-40 °F ... +158 °F (Single device) -40 °F ... +140 °F (Group assembly)
Note	The installation conditions affect the ambient temperature. Observe the "Cabinet installation guide".
Storage temperature °C	-40 °C ... +80 °C
Storage temperature °F	-40 °F ... +176 °F
Max. relative humidity	95%
Use at the height of	< 2000 m
Electromagnetic compatibility	Tested to the following standards and regulations: EN 61326-1 For use in industrial areas; NAMUR NE 21

Mechanical Data

Degree of protection (IP)	IP30
Degree of protection (IP) terminals	IP20
Fire resistance (UL 94)	V0
Enclosure material	Polyamide
Grid dimension	17.6 mm
Width	17.6 mm
Width, inches	0.69 in
Height	114.5 mm
Height, inches	4.51 in
Length	128 mm
Length, inches	5.04 in
Weight	135 g
Weight	0.3 lb

Mounting / Installation

Mounting type	DIN rail NS35/15, NS35/7.5
Mounting orientation	Vertical Horizontal
Connection type	Spring clamp terminal
Min. rigid conductor cross section	0.2 mm ²
Max. rigid conductor cross section	2.5 mm ²
Min. flex conductor cross section	0.2 mm ²
Max. flex conductor cross section	2.5 mm ²
Connection cross-section AWG	24 ... 14

Isolator Barriers

Frequency transmitter



Ex i field circuit

9146/20-11-11k Art. No. 159887

Technical Drawings – Subject to Alterations

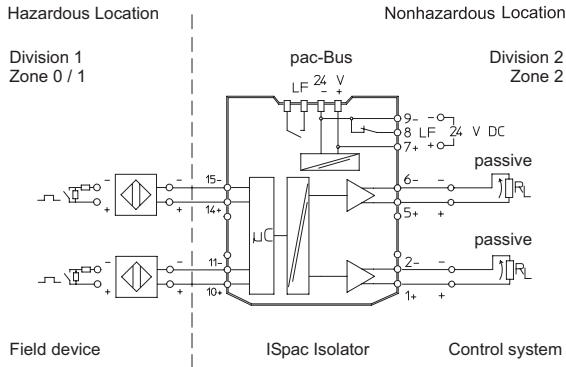

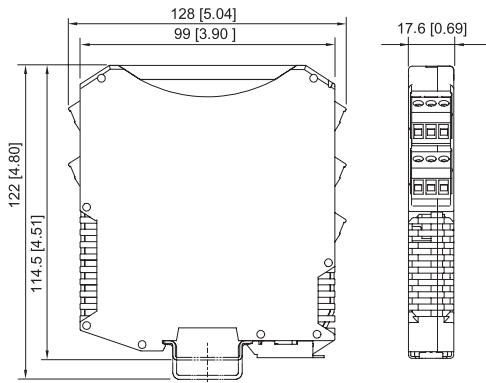

Connection diagram 9146/20-11-11

Dimensional Drawings (All Dimensions in mm [inches]) – Subject to Alterations



ISpac Series 9146, 9147, 9160, 9162, 9163, 9165, 9167, 9170, 9172, 9175, 9176, 9180, 9182, 9193, Fieldbus Power Supply Series 9412 with spring clamp terminal

Accessories

9146 Parameterisation		Art. No.
	Parameterisation ex works optionally available for all variants.	270534
Parameterization set ISpac - Wizard		Art. No.
	The software serves for commissioning, configuring and diagnosing the ISpac isolators Series 9146, 9162, 9182 and 9282. For further information, see operating instructions. Form of delivery: USB stick; parameterization software incl. parameterization cable / adaptor System requirements: IBM compatible PC with MS XP, Vista, Windows 7, 10 RS 232 C interface RS 232 / USB adaptor	202595
Resistive coupling element		Art. No.
	The 0/4 to 20 mA signal of channel 1 is converted to a 0/2 to 10 V signal. The resistive coupling element replaces the existing connection terminal. (Set with 5 pieces)	273968

Isolator Barriers

Frequency transmitter

Ex i field circuit

9146/20-11-11k Art. No. 159887

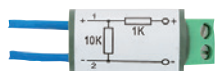

Additional connection of contacts also in hazardous areas to enable short-circuit and wire breakage detection

105944

We reserve the right to make alterations to the technical data, dimensions, weights, designs and products available without notice. The illustrations cannot be considered binding.