

# Isolator Barriers

Loop-powered binary output

Ex i field circuit

9176/20-15-00s Art. No. 222180



- Suitable for solenoid valves and signalling devices
- Two-channel variants reduce the amount of space required
- No need for a separate auxiliary power supply

MY R. STAHL 9176A



9176 series binary outputs issue binary signals for the intrinsically safe operation of Ex i solenoid valves, indicator lamps or horns. The devices do not require a separate auxiliary power supply as they are powered by the control circuit. The intrinsically safe outputs are galvanically separated from the inputs. The two-channel variants are characterised by galvanically separated channels.

## Technical Data

Explosion Protection	
Application range (zones)	2
Ex interface zone	0, 1, 2, 20, 21, 22
IECEX gas certificate	IECEX BVS 13.0012 X
IECEX gas explosion protection	Ex nA [ia Ga] IIC T4 Gc
IECEX dust certificate	IECEX BVS 13.0012 X
IECEX dust explosion protection	[Ex ia Da] IIIC
ATEX gas certificate	BVS 04 ATEX E 075 X
ATEX gas explosion protection	⊕ II 3 (1) G Ex nA [ia Ga] IIC T4 Gc
ATEX dust certificate	BVS 04 ATEX E 075 X
ATEX dust explosion protection	⊕ II (1) D [Ex ia Da] IIIC
FMus certificate	FM16US0122X
cFM certificate	FM16CA0067X
Marking cFMus	Class I, Div. 2, Groups A,B,C,D; Class I, Zone 2, Group IIC AIS Class I,II,III, Div. 1, Groups A,B,C,D,E,F,G; Class I, Zone 0, [AEx/Ex ia] IIC T4 Mounting vert. at Ta = 70°C , or horizontal Ta = 60°C See Doc. 91 766 01 31 1
Certificates	ATEX (BVS), Brazil (ULB), Canada (FM), IECEX (BVS), SIL (exida), USA (FM)
Ship approval	CCS, EU RO MR (DNV)
Declaration of conformity	ATEX (EUK), China (CCC)
Safety Data	
Max. voltage $U_o/V_{oc}$	27.6 V
Max. current $I_o$ (Ex ia)	86.5 mA
Max. current $I_o$ (Ex ib)	44 mA
Max. power $P_o$	596 mW

# Isolator Barriers

Loop-powered binary output

Ex i field circuit

9176/20-15-00s Art. No. 222180



## Safety Data

Max. permissible external capacitance $C_o/C_a$ for IIC	0.085 $\mu$ F
Max. permissible external inductance $L_o/L_a$ for IIC	1.8 mH
Max. permissible external capacitance $C_o/C_a$ for IIB	0.667 $\mu$ F
Max. permissible external inductance $L_o/L_a$ for IIB	17 mH
Internal capacitance	1.1 nF
Internal capacitance	1.1 nF
Internal inductance	Negligible
Max. voltage $U_o$ parallel	27.6 V
Max. power $P_o$ parallel	1192 mW
Max. current $I_o$ (Ex ia) paral.	173 mA
Max. current $I_o$ (Ex ib) paral.	88 mA
Internal capacitance parallel	2.2 nF
Internal inductance parallel	negligible
Safety-related max. voltage	253 V
Intrinsically safe limiting values inductance $L_o$ /capacitance $C_o$	Max. connectable inductance $L_o$ /capacitance $C_o$ 2 parallel channels
IIC	$L_o$ [mH] $C_o$ [ $\mu$ F]
IIB	$L_o$ [mH] $C_o$ [ $\mu$ F]
IIIC	$L_o$ [mH] $C_o$ [ $\mu$ F]

## Electrical Data

Number of channels	2
Internal resistance $R_i$	320 $\Omega$

## Auxiliary Power

Auxiliary power	without
Auxiliary power consumption	0.5 W + ( $I_a$ x 37 mW/mA)
Polarity reversal protection	Yes

## Galvanic Isolation

Test voltage as per standard	EN IEC 60079-11
Ex i input to Ex i input	500 V AC
Test voltage as per standard	EN 50178
Input to input	350 V AC

## Input

Input	In accordance with EN 61131-2
Input voltage for ON	18 – 31.2 V
Input voltage for OFF	0 – 5 V
Control Power $P_E$	0.5 W+ ( $I_A$ x 37 mW/mA) (with $I_A$ = max. required output current)

## Output

Output open-circuit voltage $U_a$	25 V
-----------------------------------	------

# Isolator Barriers

Loop-powered binary output

Ex i field circuit

9176/20-15-00s Art. No. 222180



## Output

Max. output current $I_{a\max}$	29 mA
Max. output current $I_a$ note	Parallel channels: 58 mA
Internal resistance $R_i$ note	320 $\Omega$ /parallel: 160 $\Omega$
Output residual ripple	< 100 mV
Output switching frequency	$\leq$ 10 Hz
Switching delay ON/OFF	$\leq$ 50 ms
Switching delay OFF/ON	$\leq$ 18 ms
Switching state indication	Yellow "OUT"; LED

9176/0-15-00 output characteristic

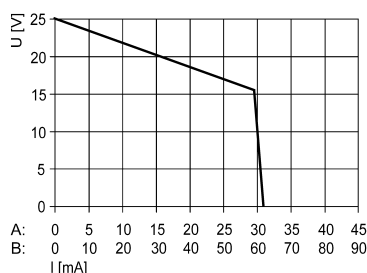

At  $U_N$ ; -20 to +60 °C

X axis (I [mA])

A: Characteristic curve for each channel

B: Characteristic curve for channel 1, parallel channel 2 (only types 9176/20-...-...)

## Ambient Conditions

Ambient temperature °C	-20 °C ... 70 °C (Single device) -20 °C ... 60 °C (Group assembly)
Ambient temperature °F	-4 °F ... +158 °F (Single device) -4 °F ... +140 °F (Group assembly)
Note	The installation conditions affect the ambient temperature. Observe the "Cabinet installation guide".
Storage temperature °C	-40 °C ... 80 °C
Storage temperature °F	-40 °F ... +176 °F
Max. relative humidity	95%
Use at the height of	< 2000 m
Electromagnetic compatibility	Tested to the following standards and regulations: EN 61326-1 For use in industrial areas; NAMUR NE 21

## Mechanical Data

Degree of protection (IP)	IP30
Degree of protection (IP) terminals	IP20
Fire resistance (UL 94)	V0
Enclosure material	Polyamide
Min. rigid conductor cross section	0.2 mm <sup>2</sup>
Max. rigid conductor cross section	2.5 mm <sup>2</sup>
Min. flexible conductor cross section	0.2 mm <sup>2</sup>
Max. flexible conductor cross section	2.5 mm <sup>2</sup>
Width	17.6 mm
Width	17.6 mm
Width, inches	0.69 in
Height	114.5 mm
Height	114.5 mm
Height in inches	4.51 in
Length	108 mm
Length in inches	4.25 in

# Isolator Barriers

Loop-powered binary output

Ex i field circuit

9176/20-15-00s Art. No. 222180



## Mechanical Data

Weight	185 g
--------	-------

## Mounting / Installation

Mounting type	DIN rail NS35/15, NS35/7.5
Grid dimension	17.6 mm
Mounting orientation	Vertical Horizontal
Connection type	Screw terminal
Connection cross-section AWG	24 ... 14

## Technical Drawings – Subject to Alterations

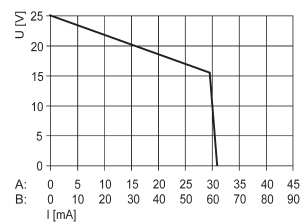

9176/0-15-00 output characteristic

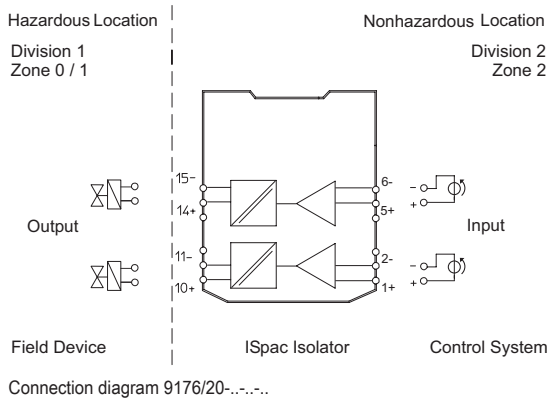
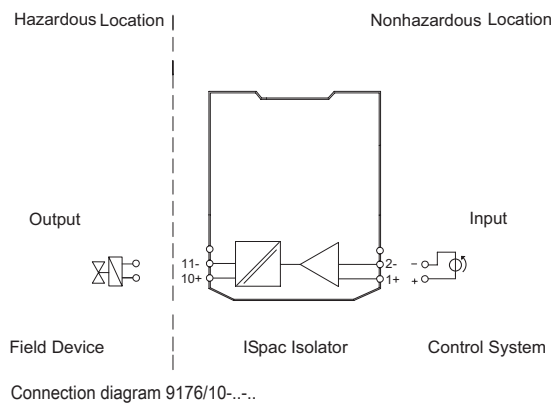

## Accessories

### Ex i/Ex e relay module for Zone 1



The Ex i/Ex e relay module is used for the galvanically isolated switching of intrinsically safe (Ex i) and non-Ex i (Ex e) electrical circuits.  
 Coil circuit: Ex i or non-Ex i (Ex e)  
 Contact circuit: Ex i or non-Ex i (Ex e)  
 Thanks to the integrated safeguarding for the contact and coil circuit, additional safeguarding is not necessary.

Usable with the following ISpac isolators: 9175/10-16-11, 9175/20-16-11, 9176/20-15-00, 9176/10-16-00, 9176/20-16-00, 9275/10-24-48-11, 9276/10-21-60-00, 9276/10-24-48-00  
 Usable with the following IS1+ modules: 9475/32-04-22, 9475/32-08-62, 9475/33-08-60

Art. No.

273000

# Isolator Barriers







Loop-powered binary output

Ex i field circuit

9176/20-15-00s Art. No. 222180



## Spare Parts

Screw terminal		Art. No.
	3-pole plug, screw connector thread: M3 stripping length: 7 mm color: green	112817
	3-pole plug, screw connector thread: M3 stripping length: 7 mm color: black	112816
	3-pole plug, screw connector thread: M3 stripping length: 7 mm color: blue	112818
Spring clamp terminal		Art. No.
	3-pole plug with test tap, spring clamp connection stripping length: 10 mm color: green	112825
	3-pole plug with test tap, spring clamp connection stripping length: 10 mm color: black	112824
	3-pole plug with test tap, spring clamp connection stripping length: 10 mm color: blue	112826

We reserve the right to make alterations to the technical data, dimensions, weights, designs and products available without notice. The illustrations cannot be considered binding.