

Isolator Barriers

Transmitter supply unit With limit contact

Ex i field circuit

9162/13-11-14s Art. No. 238251



- Compact limit value switch with 2 configurable limiting values and 4 ... 20 mA output
- Suitable for 2-, 3-wire transmitter, 2-wire HART transmitter and mA-sources
- Intrinsically safe input [Ex ia] IIC
- Open-circuit and short-circuit monitoring and messaging
- For use up to SIL 2 (IEC 61508)

MY R. STAHL 9162A



9162 series Ex i transmitter power supply units with limit values can be used for the intrinsically safe operation of two- and three-conductor transmitters or for connecting to intrinsically safe mA sources. Two limit values can be easily set using the "ISpac Config" software. If the value exceeds or falls below these limit values, these units will issue an alert. A wire-breakage and short-circuit monitoring system provides increased availability.

Technical Data

Explosion Protection	
Application range (zones)	2
Ex interface zone	0, 1, 2, 20, 21, 22
IECEX gas certificate	IECEX BVS 15.0013 X
IECEX gas explosion protection	Ex nA nC [ja Ga] IIC T4 Gc
IECEX dust certificate	IECEX BVS 15.0013 X
IECEX dust explosion protection	[Ex ia Da] IIIC
ATEX gas certificate	BVS 15 ATEX E018 X
ATEX gas explosion protection	⊕ II 3 (1) G Ex nA nC [ja Ga] IIC T4 Gc
ATEX dust certificate	BVS 15 ATEX E018 X
ATEX dust explosion protection	⊕ II (1) D [Ex ia Da] IIIC
FMus certificate	FM16US0122X
cFM certificate	FM16CA0067X
Marking cFMus	Class I, Div. 2, Groups A,B,C,D; Class I, Zone 2, nA nC Group IIC AIS Class I,II,III, Div. 1, Groups A,B,C,D,E,F,G; Class I, Zone 0, [AEx/Ex ia] IIC T4 at Ta = 70°C See Doc. 9162 6 031 001 1
Certificates	ATEX (BVS), Canada (FM), China (NEPSI), IECEX (BVS), SIL (exida), USA (FM)
Ship approval	CCS, EU RO MR (DNV)
Declaration of conformity	ATEX (EUK), China (CCC)
Safety Data	
Max. voltage U_o/V_{oc}	27 V
Max. current I_o/I_{sc}	87.9 mA
Max. power P_o	574 mW
Max. permissible external capacitance C_o/C_a for IIC	0.09 μ F

Isolator Barriers

Transmitter supply unit With limit contact

Ex i field circuit

9162/13-11-14s Art. No. 238251



Safety Data

Max. permissible external inductance L_o/L_a for IIC	2.3 mH			
Max. permissible external capacitance C_o/C_a for IIB	0.705 μ F			
Max. permissible external inductance L_o/L_a for IIB	14 mH			
Max. perm. ext. capacit. IIIC	0.705 μ F			
Max. permis. ext. induct. IIIC	14 mH			
Max. voltage U_o (3-wire)	27 V			
Max. current I_o (3-wire)	88.3 mA			
Max. power P_o (3-wire)	574 mW			
Max. permissible external capacity C_o for IIC (3-wire)	0.09 μ F			
Max. permissible external inductance L_o for IIC (3-wire)	2.3 mH			
Max. permissible external capacity C_o for IIB (3-wire)	0.705 μ F			
Max. permissible external inductance L_o for IIB (3-wire)	14 mH			
Max. permissible external capacity C_o for IIIC (3-wire)	0.705 μ F			
Max. permissible external inductance L_o for IIIC (3-wire)	14 mH			
Internal capacitance (3-conductor)	negligible			
Internal inductance (3-conductor)	negligible			
Max. voltage U_o isolation amplifier	4.1 V			
Max. current I_o isolation amplifier	\approx 0 mA			
Max. power P_o isolation amplifier	\approx 0 mW			
Internal capacitance isolation amplifier	Negligible			
Internal inductance L_i isolation amplifier	Negligible			
Max. voltage U_i	30 V			
Max. current I_i	100 mA			
Internal capacitance	Negligible			
Internal inductance	Negligible			
Safety-related max. voltage	253 V			
Intrinsically safe limiting values inductance L_o /capacitance C_o	Jointly connectable inductance L_o /capacitance C_o			
IIC	L_o [mH]	1 mH	0.500 mH	0.200 mH
	C_o [μ F]	0.056 μ F	0.072 μ F	0.090 μ F
IIB	L_o [mH]	10 mH	1 mH	0.200 mH
	C_o [μ F]	0.290 μ F	0.380 μ F	0.600 μ F
IIIC	L_o [mH]	10 mH	1 mH	0.200 mH
	C_o [μ F]	0.290 μ F	0.380 μ F	0.600 μ F

Electrical Data

Number of channels	1
Transmitter feed operation	Yes
Isolation amplifier operation	Yes

Isolator Barriers

Transmitter supply unit With limit contact

Ex i field circuit

9162/13-11-14s Art. No. 238251



Electrical Data

LFD relay	Yes
Communication signal	HART, 0.5 to 10 kHz
Limiting values configuration	Using ISpac Config

Auxiliary Power

Auxiliary power	24 V DC
Auxiliary power nominal voltage	24 V DC
Auxiliary power voltage range	18 ... 31.2 V
Auxiliary pwr nom. voltage DC	24 V
Voltage range residual ripple	$\leq 3,6 V_{SS}$
Nominal current	85 mA
Max. power dissipation	1.5 W
Power consumption	2 W
Polarity reversal protection	Yes
Undervoltage monitoring	Yes
Operation indication	Green "PWR" LED

Galvanic Isolation

Test voltage as per standard	EN IEC 60079-11
Ex i input to output	1.5 kV AC
Ex i input to auxiliary power	1.5 kV AC
Ex i input to fault message contact	1.5 kV AC
Test voltage as per standard	EN 50178
Output to auxiliary power	350 V AC
Output to output	350 V AC
Galvanic separation FMC to HE and output	350 V AC

Input

Input function	Isolation amplifier Transmitter power unit
Input	4 to 20 mA with HART
Input signal	4 to 20 mA with HART
Function range input	2 – 22 mA
Max. input current, mA sources	50 mA
Input for open-circuit voltage U_a	$\leq 26 V$
Short-circuit current	$\leq 35 mA$
Supply voltage for transmitter	$\geq 16 V$ at 20 mA
Note about supply voltage	($T < -10 ^\circ C$: US - 0.2 V / 10K)
HART input resistance (AC)	$> 250 \Omega$
Input resistance	30Ω

Output

Output	4 to 20 mA with HART
Output signal	4 to 20 mA with HART
Function range output	2 – 22 mA
Behaviour of the output	= input signal
Output residual ripple	$\leq 40 \mu A_{eff}$
Load resistance R_L	0 to 600 Ω (terminal 1+/2-)

Isolator Barriers

Transmitter supply unit With limit contact

Ex i field circuit

9162/13-11-14s Art. No. 238251



Output	
Load resistance influence	≤ 0,02 %
Analog signal delay	< 30 ms
Settling time 10-90%	< 45 ms
Limit contact (per channel)	2 NO
Switching voltage limiting values	≤ ± 30 V
Switching current limiting values	≤ 170 mA
Limit value contact switching current (max. 1 ms)	≤ 500 mA
Switch-on resistance	≤ 2.5 ohm (typical < 1 ohm)
Switching state indication	Yellow "OUT" LED
Switching delay	< 80 ms
Switch-back delay	< 100 ms
Reclosing lockout	Reset using DIP switch or "Power off" (configurable)
LF switch user adjustment	Activated/deactivated
Wire breakage error detection input	< 3.6 mA
Short circuit error detection input	> 21 mA
Line fault indication	Red "LF" LED
Fault message contact switching capacity	30 V / 100 mA
Line fault and loss of power signalization	- Contact (30 V/100 mA), closed against earth in case of error - pac-Bus, potential-free contact (30 V/100 mA)
Deviations / error note	Information in % of the measuring range (20 mA) at U _N , 23 °C
Deviation	≤ 0,2 %
Temperature influence error limits	≤ 0.1%/10 K
Auxiliary power influence error limits	≤ 0,01 %
Linearity error	≤ 0,1 %
Offset error	≤ 0,1 %
Behaviour of the output	= input signal
Device Specific Data	
LED operating conditions	LED "PWR", green
Ambient Conditions	
Ambient temperature °C	-40 °C ... 70 °C (Single device) -40 °C ... 60 °C (Group assembly)
Ambient temperature °F	-40 °F ... +158 °F (Single device) -40 °F ... +140 °F (Group assembly)
Note	"The installation conditions affect the ambient temperature. Observe the "Cabinet installation guide""
Storage temperature °C	-40 °C ... 80 °C
Storage temperature °F	-40 °F ... +176 °F
Max. relative humidity	95%
Use at the height of	< 2000 m
Max. operating altitude	2000 m
Electromagnetic compatibility	Tested to the following standards and regulations: EN 61326-1 For use in industrial areas; NAMUR NE 21
Mechanical Data	
Degree of protection (IP)	IP30
Degree of protection (IP) terminals	IP20

Isolator Barriers

Transmitter supply unit With limit contact

Ex i field circuit

9162/13-11-14s Art. No. 238251



Mechanical Data

Fire resistance (UL 94)	V0
Enclosure material	Polyamide
Min. rigid conductor cross section	0.2 mm ²
Max. rigid conductor cross section	2.5 mm ²
Min. flexible conductor cross section	0.2 mm ²
Max. flexible conductor cross section	2.5 mm ²
Connection cross-section	0.2 to 2.5 mm ² flexible 0.25 to 2.5 mm ² flexible with core end sleeve
Width	17.6 mm
Width, inches	0.69 in
Height	114.5 mm
Height in inches	4.51 in
Length	108 mm
Length in inches	4.25 in
Weight	225 g

Mounting / Installation

Mounting type	DIN rail NS35/15, NS35/7.5
Grid dimension	17.6 mm
Mounting orientation	Vertical Horizontal
Connection type	Screw terminal
Connection cross-section AWG	24 ... 14

Technical Drawings – Subject to Alterations

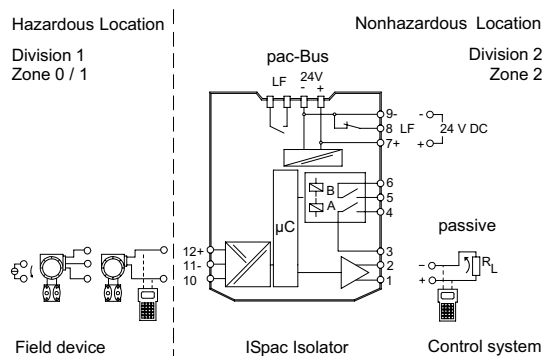

Connection diagram 9162/13-11-14

Isolator Barriers

Transmitter supply unit With limit contact

Ex i field circuit

9162/13-11-14s Art. No. 238251



Dimensional Drawings (All Dimensions in mm [inches]) – Subject to Alterations

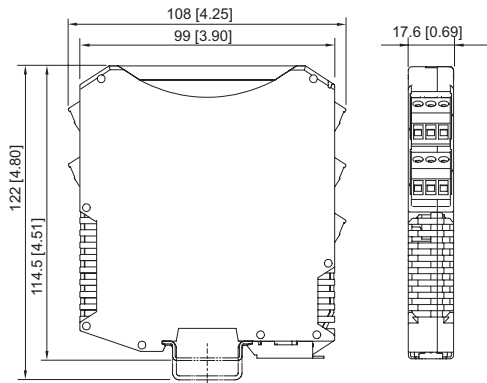

ISpac Series 9143, 9146, 9147, 9160, 9162, 9163, 9165, 9167, 9170, 9172, 9175, 9176, 9180, 9182, 9193, ISbus Series 9412 with screw terminal

Accessories

Parameterization set Series 9199 for ISpac isolators Series 9146, 9162, 9182 and 9282

Art. No.



Used for parameterization and diagnostics on 9146, 9162, 9182 and 9282 series ISpac isolators.
Interface to PC: USB
Scope of delivery: Adapter and cable (software is available to download online at r-stahl.com, Websites of the specified devices or MY R. STAHL: 9282A)

261507

Resistive coupling element

Art. No.



The 0/4 to 20 mA signal of channel 1 is converted to a 0/2 to 10 V signal. The resistive coupling element replaces the existing connection terminal. (Set with 5 pieces)

273968

Spare Parts

Screw terminal

Art. No.



3-pole plug, screw connector
thread: M3
stripping length: 7 mm
color: green

112817



3-pole plug, screw connector
thread: M3
stripping length: 7 mm
color: black

112816



3-pole plug, screw connector
thread: M3
stripping length: 7 mm
color: blue

112818

Spring clamp terminal

Art. No.



3-pole plug with test tap, spring clamp connection
stripping length: 10 mm
color: green

112825

Isolator Barriers



Transmitter supply unit With limit contact

Ex i field circuit

9162/13-11-14s Art. No. 238251



Spring clamp terminal

		Art. No.
	3-pole plug with test tap, spring clamp connection stripping length: 10 mm color: black	112824
	3-pole plug with test tap, spring clamp connection stripping length: 10 mm color: blue	112826

We reserve the right to make alterations to the technical data, dimensions, weights, designs and products available without notice. The illustrations cannot be considered binding.