

Description of

PROFINET Interface

for

IS1+ field stations



PROFINET interface description

Content

Historical development of remote I/O technology at R. STAHL.....	4
1 System overview	5
2 Commissioning	6
2.1 Overview	6
2.2 Supported PROFINET Functions	7
2.3 System requirements	7
2.4 Engineering limits	7
2.5 Configuration of IS1+ in the PROFINET controller	8
2.6 Compatibility of new IS1+ IO modules	9
2.7 PROFINET Network Topology	10
2.7.1 MRP Ring (Media Redundancy Protocol)	10
2.7.2 System Redundancy	11
2.7.3 Shared Device	12
2.7.4 Shared Input	12
2.8 Addressing and Protocol selection 9442 CPUs	13
2.8.1 DP/RS485 + SB Address setting	13
2.8.2 Protocol Selection	13
2.8.3 IP Address setting	13
2.8.3.1 PROFINET Address of IS1+ field station	14
2.8.3.2 IS1+ Detect	15
2.8.3.3 IS1+ Web Server	16
2.9 System start-up behavior	17
2.10 PROFINET functions	18
2.11 RIO Profile functions	18
2.11.1 Mode handling	19
2.11.2 Signal inversion	20
2.11.3 Scaling for AI and AO signals	20
2.11.4 Failsafe Function	22
2.11.4.1 Behavior of the input signals in case of errors	23
2.11.4.2 Behavior of the output signals in case of errors	23
2.12 Module revision mapping	23
3 Data traffic	24
3.1 Parameterization	24
3.1.1 CPU parameters	24
3.1.2 I/O module parameters	25
3.1.2.1 AIM / AIMH 9461	25
3.1.2.2 AUMH 9468	26
3.1.2.3 UMH 9469	27
3.1.2.4 TIMR 9480	29
3.1.2.5 TIM mV 9481	31
3.1.2.6 TIM 9482	32
3.1.2.7 DIM (9470/3x in compatible mode)	34
3.1.2.8 DIOM 9470/3x, 9471/35, 9472/35 (IS1+)	35
3.1.2.9 AOM / AOMH 9466	36
3.1.2.10 DOM	37
3.2 Data word structure of the I/O modules	38
3.2.1 Analogue modules	38
3.2.1.1 Analog format with status according PI specification	40
3.2.2 DIM, DIM+CF (9470/.. 9471/.. 9472/..)	45
3.2.3 DOM (9475/.., 9477/.., 9478/..)	51
3.3 HART variables	52
3.3.1 Data format	52
3.3.2 Selection of HART Variables	52
3.4 HART Maintenance via IS1 DTM	53

PROFINET interface description

3.5	Alarm- and diagnosis data	54
3.6	I&M Identification & Maintenance Functions	55
3.7	Webserver in IS1+ CPU	56
3.8	LED and LCD displays of the 9441 CPU	57
3.9	Online behavior of the IS1+ field station.	57
3.10	Transmission time:	58
4	List of abbreviations:.....	59
5	Release notes:.....	60
6	Further reading	60
7	Support address	60

Historical development of remote I/O technology at R. STAHL

As one of the innovators in remote I/O technology, R. STAHL recognized the advantages that remote I/O technology offers for hazardous areas and has been developing innovative products and solutions for over 30 years since that time. The benefits to users are always the focus here. All communication, power supply and input/output modules in the system can be connected and disconnected during operation in hazardous areas. Thanks to an intrinsically safe system design, the installation process is almost identical to this process in safe areas. No special Ex d or Ex p enclosures are required. Remote I/O can be used to integrate conventional and HART-capable field devices into modern, digital network structures easily and affordably. Comprehensive diagnostics options using a separate ServiceBus or the process bus enable integration in modern plant asset management systems and increase the availability of systems.

- 1987 The "ICS MUX fieldbus system" from R. STAHL is the first intrinsically safe bus system for sensors and actuators in hazardous areas (Zone 1) on the market. A master station installed in the control room establishes the connection to the automation systems. Intrinsically safe communication with explosion-protected on-site or field stations (VOS) installed in Zone 1 is carried out using a single coaxial cable.
- 1993 The system variant "VOS 200", which is based on ICS MUX, is presented. The "VOS 200" is better suited to smaller signal quantities or decentralized automation units. A master station is no longer required. Multi-drop is supported and couplings are also available in redundant designs.
- 1997 "VOS 200" can now also communicate with the PROFIBUS DP, which was new at the time. R. STAHL achieved this by being the first to develop an intrinsically safe design which, with a few modifications, is part of the PNO standard today under the name RS485-IS.
- 2000 Drawing from experience with the ICS MUX and VOS 200, a completely new Remote I/O – IS1 is developed. This system is substantially more flexible, easier to use, more powerful and extremely affordable. Over the years, the IS1 has become the market leader in Zone 1 and is still used around the globe. IS1 supports open bus protocols such as PROFIBUS DP or Modbus RTU and is available in different versions for Zone 1, Zone 2 and even Division 1 and 2.
- 2009 A new communication unit for Ethernet is added to IS1. With this, IS1 is the first remote I/O system that operates at 100 Mbps/Ethernet in Zone 1. A fibre optic cable with the 'op is' type of protection is used as a communication medium. Modbus TCP, EtherNet/IP and PROFINET are supported protocols.
- 2013 The I/O level is completely modernised and introduced on the market as IS1+. The new multifunctional I/O modules have configurable inputs/outputs and an innovative diagnostics function that reports potential module failures up to 12 months before they would occur. IS1+ is even better suited to extreme ambient conditions from -40 to +75 °C. The new IS1+ modules are fully compatible with their IS1 predecessors.
- 2018 The new Zone 2 head assembly consists of a CPU, power module and socket makes IS1+ even more flexible and has expanded its application range. The previously supported protocols PROFIBUS DP, Modbus TCP+RTU, EtherNet/IP and PROFINET are now all supported by one CPU and can be selected by the user. The new assembly has the same predictive diagnostic functions and the extended temperature range of -40 to 75 °C that are features of the IS1+ modules.

The description below shows the system features of the IS1+ system when connecting to an automation system via PROFINET.

PROFINET interface description

1 System overview

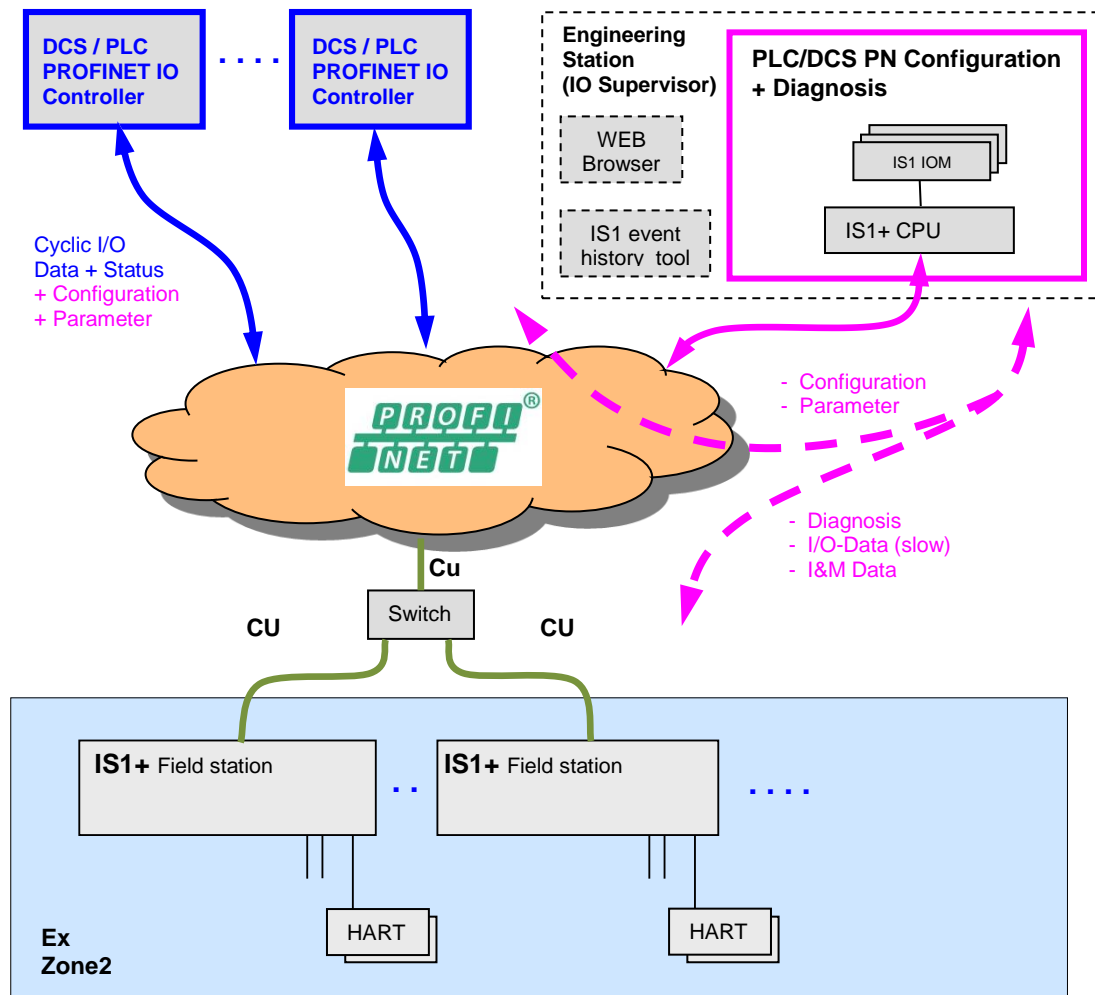

As an off-the-shelf explosion protected unit, the IS1+ field station can be installed directly in the potentially explosive atmosphere (Zone 1 or Zone 2). It can also be installed in the safe area. The diagram above shows a Zone 2 solution.

The IS1+ field station operates as PROFINET I/O device.

Configuration, parameter setting and diagnostics for the IS1+ field station and its I/O modules are carried out via GSDML description in the PROFINET Host configuration software.

A webserver is integrated in the IS1+ CPUs which offers additional diagnostic functions.

2 Commissioning

2.1 Overview

Planning of the complete PROFINET network:

- Which controller are in the network
- Which PN I/O devices are in the network
- Selection of network topology and network physics (switches, repeaters, glass fiber links ...)
- Unique allocation of the IP addresses or device names in the network.

Perform the commissioning:

- Mechanical installation of the IS1+ field station.
- Mechanical installation of the PROFINET switches
- Mechanical installation of all other bus users.

- Set up the bus connections.

- Set up the voltage supply of the IS1+ field station.
- Set up the voltage supply of the switches and other network components

- Set up the IP addresses and network device names using the configuration software of the controller.

- Configure the IS1+ field stations with its I/O modules using the GSDML File and the configuration software of the controller.

- Programming of the controller

- Set the network into operation.

- Check Ethernet connection using:
 - LED's on Ethernet Switches
 - Link LED's of CPU on IS1+ Fieldstation
 - „Ping“ command. Ping is responding in any CPU state.

- Check communication on the PROFINET using the following tools:
 - Diagnostics information from the controller and the network management software
 - LEDs on the CPU of the IS1+ field station
 - Webserver in IS1+ CPU

- Check I/O signals using the following tools:
 - Signal- and diagnosis information of the controller.

General Information regarding PROFINET see following PNO documents:

- | | |
|--|----------------|
| - PROFINET Design Guideline | PNO Doc. 8.062 |
| - PROFINET Installation Guideline for Cabling and Assembly | PNO Doc. 8.072 |
| - PROFINET Installation Guideline for Commissioning | PNO Doc. 8.082 |

PROFINET interface description

2.2 Supported PROFINET Functions

- PROFINET RT V2.3 including legacy mode
- Device accordant Conformance Class B
- Application Class “High Availability” with the focus on System Redundancy and Dynamic Reconfiguration.
- MRP Client Media redundancy protocol (Ring)
- System redundancy S2 – Support of redundant PLC/DCS *1)
- Shared Device - Distribution of device functions to various controllers *1)
- Shared Input - Multiple access to inputs by various controllers *1)
- 1024 Byte I/O data (inclusive IOPS/IOCS)
- Max. 16 physical Slots for IO-modules
- 4 ms Minimum Device Interval
- I&M 0 ... 3 (Identification and Maintenance Data)
- MIB support (IF MIB, LLDP MIB, LLDP EXT MIB, MAU MIB, PNIO MIB)
Remote mismatch detection (neighbor MRP data, peer partner port)
- SNMP V2 Topology detection and cable length measurement
Allows Simple Network Management Protocol and topology information to be read out
- NumberOfAR=3 -> max. number of application relationships (ARs) for e.g. Shared Device, System Redundancy and Supervisor AR.

*1) **Attention!** Shared Device and Shared Input cannot be used in combination with system redundancy S2!

2.3 System requirements

Hardware requirements:

- IS1+ field station with CPU 9441/12-00-00
Single socket 9492/12-11-31 or redundant socket 9492/12-11-32
- IS1+ field station with CPU 9442/35-10-00 and Socket 9496/.. and Power Module PM 9445/..

Software requirements:

IO Module	IO Module Firmware	9441 CPU		9442 CPU	
		Firmware	GSDML	Firmware	GSDML
IS1 IOM	from 02-00	from V51-05	from GSDML-V2.3-Stahl-RIO-20140206.xml	from V1.0.20	from GSDML-V2.34-Stahl-RIO9442-20200427.xml
IS1+ IOM (94xx/3x....)	from 03-01				

Siemens S7 Systems: STEP7 from V5.5 SP3 required !

2.4 Engineering limits

The general regulations according to the IS1+ operating instructions apply to the engineering of an IS1+ field station.

Maximum 1024 byte cyclic input + output data + Submodule Status IOPS/IOCS are allowed. This limits possible IO module configurations such as 16 IOM with many additional sub modules for HART and Counter Frequency (CF).

The limits and requirements on the PROFINET hosts and network components used must also be taken into account during the engineering.

PROFINET interface description

2.5 Configuration of IS1+ in the PROFINET controller

The documentation of the controller will describe the exact procedure for the configuration and parameterization of your master. As a result of the high degree of standardization of the PROFINET, the configuration and parameterization of the network and the devices is performed in a very similar fashion - even for the products of different manufacturers. Device descriptions as GSDML files are available for the IS1+ field stations. This files contain all the information important for the controller on the communication behavior, signals and parameter of the IS1+ field station. GSD files are read by the configuration software of the controller. The configuration Software of the controller takes the information on the module types possible in an IS1+ field station from the GSDML file.

The following table shows the supported I/O module types.

Typ Nummer	Kurzbezeichnung	Submodul1	Submodul2	Module ID	Generation	
9460/12-08-11	AIM 8	8 AI	-	IDM_AIM_03	IS1	
9461/12-08-11	AIMH 8		8 HV	IDM_AIM_05		
9461/12-08-21	AIMH 8			IDM_AIM_06		
9461/15-08-12	AIMH 8			IDM_AIM_07		
9465/12-08-11	AOM 8	8 AO	-	IDM_AOM_09	IS1	
9466/12-08-11	AOMH 8		8 HV	IDM_AOM_11		
9466/15-08-12	AOMH 8			IDM_AOM_12		
9468/3x-08-xx	AUMH 8	8AI + 8AO	8 HV	IDM_AUIM_43	IS1+	
9469/35-08-xx	UMH 8 Exn *1)	8AI + 8AO	8 HV	IDM_UIM_50	IS1+	
9470/22-16-11	DIM 16	16 DI	2 CF	IDM_DIM_13	IS1	
9470/25-16-12	DIM 16			IDM_DIM_14		
9470/3x-16-xx	DIOM 16	16 DI+16 DO	8 CF	IDM_DIOM_IM_44	IS1+	
9471/15-16-12	DIM 16	16 DI	2 CF	IDM_DIM_17	IS1	
9471/35-16-xx	DIOM 16 Exn *1)	16 DI+16 DO	8 CF	IDM_DIOM_IM_48	IS1+	
9472/35-16-xx	DIOM 16 24V Exn *1)	16 DI+16 DO	8 CF	IDM_DIOM_IM_49		
9475/12-04-11	DOM 4	4 DO	-	IDM_DOM_18	IS1	
9475/12-04-21	DOM 4			IDM_DOM_19		
9475/12-04-31	DOM 4			IDM_DOM_20		
9475/12-08-41	DOM 8	8 DO		IDM_DOM_22		
9475/12-08-51	DOM 8			IDM_DOM_23		
9475/12-08-61	DOM 8			IDM_DOM_24		
9475/22-04-21	DOM 4	4 DO		IDM_DOM_36		
9475/22-08-51	DOM 8	8 DO		IDM_DOM_32		
9475/22-08-61	DOM 8			IDM_DOM_33		
9475/3x-04-xx	DOM 4	4 DO		IDM_DOM_45		IS1+
9475/3x-08-xx	DOM 8	8 DO		IDM_DOM_46		
9477/12-08-12	DOM 8 60V Rel Z1	8 DO		IDM_DOM_34		IS1
9477/12-06-12	DOM 6 250VRel Z1	6 DO		IDM_DOM_35		
9477/15-08-12	DOM 8 Rel Z2	8 DO		IDM_DOM_30		
9478/22-08-51	DOMV8 OD			IDM_DOM_42		
9480/12-08-11	TIM 8 R	8 TI		IDM_TIM_26		
9481/12-08-11	TIM 8 mV	8 TI		IDM_TIM_28		
9482/3x-08-xx	TIM 8	8 TI		IDM_TIM_47	IS1+	

*1) Exn IO modules are permitted in Ex zone 1 only and are supported with the 9442 CPU only. This IOM can be used with 9441 CPUs in compatible mode, see [Compatibility of new IS1+ IO modules](#).

PROFINET interface description

2.6 Compatibility of new IS1+ IO modules

New IS1+ IO modules can be used in existing plants for compatible replacement of previous IS1 IO modules. No change of GSD File or configuration is required in such case.

The IS1+ IO module switch to a compatible mode in case of detection of an allowed configuration of the previous IO module.

If new features of the IS1+ IO modules shall be used which are not supported by the previous IO module new configuration according type number of the IS1+ IO module is required.

Overview of compatible IO module:

IS1 IO module		compatible IS1+ IO module	Remark
9460/12-08-11	AIM 8	9468/32-08-11 AUMH Zone 1 9468/33-08-10 AUMH Zone 2	-
9461/12-08-11	AIMH 8		-
9461/12-08-21			9164 additionally required
9465/12-08-11	AOM 8		-
9466/12-08-11	AOMH 8		-
9461/15-08-12	AIMH 8 Exn	9469/35-08-xx UMH Exn	-
9466/15-08-12	AOMH 8 Exn		-
9470/22-16-11	DIM 16	9470/32-16-11 DIOM Zone 1	-
9475/12-08-41	DOM 8	9470/33-16-10 DIOM Zone 2	
9470/25-16-12	DIM 16 Nam Exn	9471/35-16-xx DIOM Zone 2 Exn 9472/35-16-xx DIOM 24V Exn (from IOM Firmware V03-06)	-
9471/15-16-12	DIM 16 24V Exn		-
9471/10-16-11	DIM 16 24V		-
9475/12-04-11	DOM 4	9475/32-04-12 DOM Zone 1	-
9475/12-04-21		9475/32-04-22 DOM Zone 1	-
9475/12-04-31		-	discontinued
9475/12-08-41	DOM 8	see above 9470/3x DIOM	-
9475/12-08-51		9475/32-08-52 DOM Zone 1 9475/33-08-50 DOM Zone 2	-
9475/12-08-61		9475/32-08-62 DOM Zone 1 9475/33-08-60 DOM Zone 2	-
9475/22-04-21		DOM 4 OD	9475/32-04-22 DOM Zone 1
9475/22-08-51	DOM 8 OD	9475/32-08-52 DOM Zone 1	-
9475/22-08-61		9475/32-08-62 DOM Zone 1	-
9480/12-08-11	TIM R	9482/3x-08-xx 8TIM	-
9481/12-08-11	TIM mV		-

Note: The real plugged IO module type will be reported about I&M functions. Thus the plugged IO module type for IO modules in compatible mode will be shown in online diagnosis only. Offline, the configured type will be shown.

PROFINET interface description

2.7 PROFINET Network Topology

The IS1 + 9442 CPU has two Ethernet ports (X2, P1, as well as X2, P2) which are internally connected via an Ethernet switch. Thus, it is possible to build Ethernet star-, line- (daisy chains) as well as MRP Ring topologies (Media Redundancy Protocol). The IS1+ 9441 CPU has only one Ethernet port. Star topologies are possible with this CPU only.

To build up ring topologies MRP enabled components in accordance with PROFINET specification are to be used and configured.

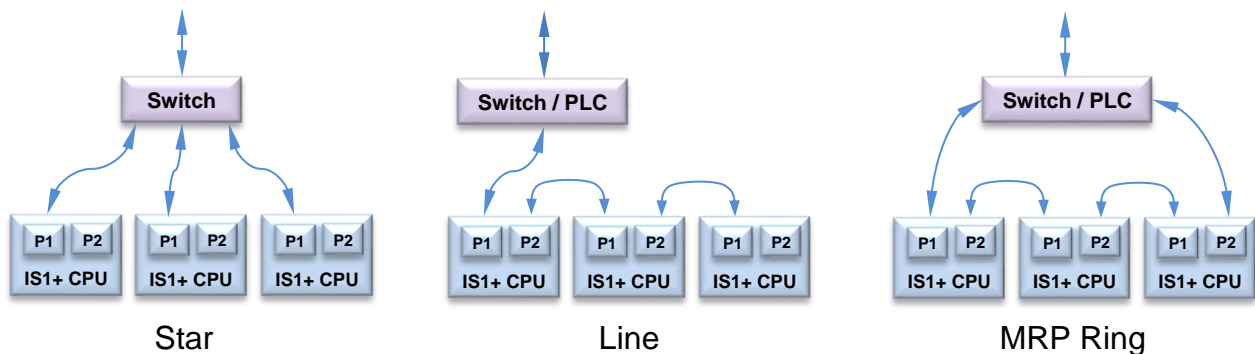

Maintenance Note: The internal switch and the Port P2 of a 9442 CPU are disabled during a software update. Following Network participants connected on port P2 are therefore unavailable in this phase of the operation.

2.7.1 MRP Ring (Media Redundancy Protocol)

Preconditions for trouble-free operation with media redundancy MRP

- The maximum number of devices per ring limited (such as typical 50 devices). Details see the operating instructions of the ring Manager. Exceeding the number of devices can lead to the loss of traffic.
- The ring, in which you want to use MRP, shall consist of devices that support this feature.
- All devices must be connected to each other through their ring ports.
- For all devices in the ring "MRP" must be enabled - all devices as "MRP Client" except for a device with the "Manager" role.
- Alternatively, multiple devices in the ring can have a role "Manager (Auto)". The devices with the role "Manager (Auto)" will arrange the task of the redundancy Manager automatically. In this case, no device may hold the "Manager" role.
- The IS1+ 9442 CPU has the role of "MRP Client".
- Reconfiguration time of a MRP ring after error: typ. 200 ms
- MRP according to IEC 62439-2

PROFINET interface description

Rule for loading the devices of a MRP domain

- Loading devices of a MRP domain (a ring) can come to circular frames (broadcast storm) and thus the loss of the network if there is an invalid MRP project planning.
- Example: You change the MRP roles from multiple devices and load the configuration in the participating devices one at a time. Configurations may arise which conflict with the above rules, such as devices with the "Manager" role and "Manager (auto)" could exist at the same time in the ring.
- Open the MRP ring before downloading to avoid an invalid configuration which will lead to a failure of the network.
- Proceed as follows:
 1. Open the ring.
 2. Download the healthy and consistent MRP project planning of your project to all participating devices and make sure that the devices are in data exchange.
 3. Close the ring.

MRP and Realtime (RT)

RT operation is possible with the use of MRP. During the reconfiguration time of the ring after a failure, the I/O data will be frozen.

Caution! Select the Watchdog time of the IO devices large enough.

Typical > = 200 ms.

The RT communication is interrupted (station failure) if the reconfiguration time of the ring is greater than the Watchdog time of the IO devices.

Example:

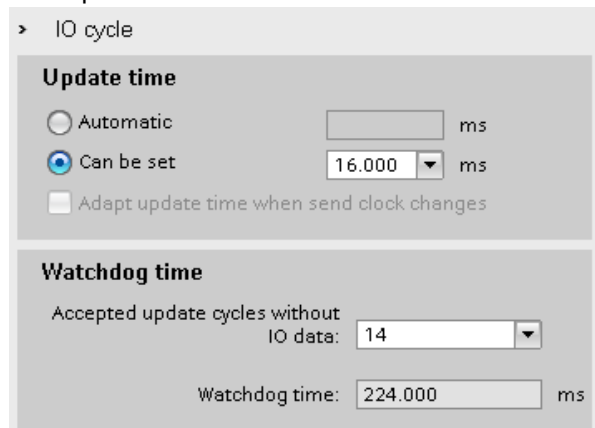

2.7.2 System Redundancy

Single Network Access Point NAP with two IO Controller – S2

The IS1+ 9442 CPU supports PROFINET S2 system redundancy according PNO Spec. (PNO doc. 7.122). Redundant IO controllers with support of this feature are required for konfiguration and operation.

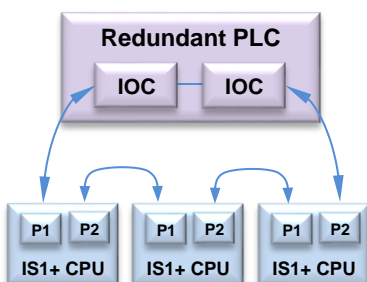

Example for S2 System Redundancy:

- Redundant IO Controller
- Single IS1+ CPUs (NAP)
- MRP Ring

PROFINET interface description

2.7.3 Shared Device

The IS1+ 9442 CPU supports the PROFINET function 'Shared Device' Modules and Submodules of an IO-device can be logically allocated between various IO-Controllers (IOC). Every Submodule of a shared device is exclusively associated with an IO-controller. For use the function 'shared device' must also be supported by the used IO controllers. Some particularities must be observed in the project planning of IO-Controllers using shared devices. For details refer to the operating instructions of the IO controller.

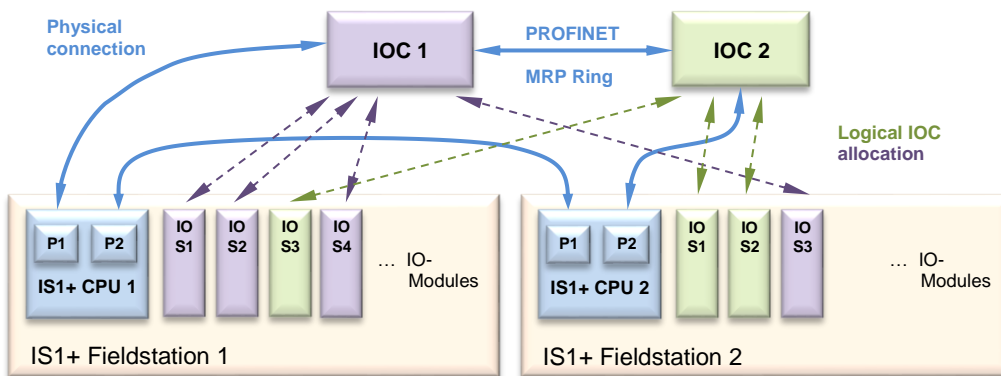

2.7.4 Shared Input

The IS1+ 9442 CPU supports the PROFINET function 'shared input' which allows multiple access to inputs by various controllers. For details refer to the operating instructions of the IO controller.

Attention!

Shared Device and Shared Input cannot be used in combination with system redundancy S2!

PROFINET interface description

2.8 Addressing and Protocol selection 9442 CPUs

2.8.1 DP/RS485 + SB Address setting

A common station address is used from the 9442 CPU for the protocols PROFIBUS DP as well as the STAHL service bus via USB/RS485, which is adjustable via two rotary switches S2, S3 on the first IS1+ socket (Bank 0).

The switch is located under the left CPU.

This has the advantage that the switches can not accidentally be changed during operation.

Changed switch settings will be accepted after CPU boot only.

Address Range (0 – 99)

Address = S2 x 10 + S3



2.8.2 Protocol Selection

The required AS Protocol can be set by a rotary switch S1 on the IS1+ 9442 CPU socket.

In case of CPU exchange this settings keep unchanged.

After changes of the selected Protocol, matching configuration and parameter data must be created and loaded to the IS1+ field station.

AS-Protocol	S1 switch setting
Reserved	0
PROFIBUS PNO Red.	1
PROFIBUS Stahl Red. Addr. Offs. 1	2
PROFIBUS Stahl Red. Addr. Offs. 0	3
PROFINET	4
Reserved	5
Modbus TCP	6
EtherNet/IP	7
Reserved	8
Reserved	9

2.8.3 IP Address setting

Two separate IP addresses for the Ethernet communication are available for the 9442 IS1 CPU:

- IP-AS: Realtime bus to automation system (MODBUS TCP, PROFINET, EtherNet/IP,)
- IP-SB: Service Bus Functions: Web-Server, IS1 DTM, HART, Standard TCP Traffic, SW-Update

This separation of IP Addresses allows enhanced independence of the different data streams also if both data streams are transmitted via the same Ethernet ports. A change of IP addresses is blocked during active data exchange to the Automation System.

Caution! IP-AS, IP-SB addresses and Devicenames of CPUs must be unique as all addresses of an Ethernet network.

The IP address information is stored in the socket backup memory as well. Configuration and address information of an IS1+ field station are therefore preserved in case of exchange of CPUs.

PROFINET interface description

2.8.3.1 PROFINET Address of IS1+ field station

The following information is required to address an IS1+ field station on PROFINET:

- Devicename (Allocation via PN IO-Supervisor)
- IP address (Usually done automatically by PN IO-Supervisor)
- SubNet mask
- optional: Gateway (only necessary for communication via routers)

The addresses for an IS1+ field station can be set via:

- Preferred during operation of PROFINET
 - from Network configuration software of the controller (PN IO-Supervisor)
- Optional possible (e.g. for operation without PN IO-Supervisor during commissioning)
 - Buttons and display on IS1 9441 CPU.
 - BOOTP Server (9441 CPU only)
 - IS1+ Webserver
 - IS1+ Detect Tool (9442 CPU only)

PROFINET name conventions:

- Limit of a total of 127 characters (letters "a" to "z", numbers "0" to "9", hyphens, periods).
- A name component within the device name, a character string between two periods, for example, must not be longer than 63 characters.
- No special characters like umlauts, parentheses, underscore, slash, space etc. The hyphen is the only special characters allowed.
- The device name must not contain uppercase letters.
- The device name must not begin nor end with the "-" or "." character.
- The device name must not begin with a number.
- The device name must not have the form "n.n.n.n" (n = 0...999).
- The device name must not begin with the character string "port-xyz-" (x,y,z = 0...9).

PROFINET interface description

2.8.3.2 IS1+ Detect

The 'IS1+ Detect' tool can scan the Ethernet Network for connected IS1+ field stations with 9442 CPUs and display the IP addresses of the found CPUs. This applies also to stations which are outside of the IP-addressable address range of the network.

IP-SB addresses of found IS1+ 9442 CPUs can be changed if necessary and must be inside of the IP-addressable address range of the network.

Thus the IS1+ CPUs are accessible via the integrated Web server. Diagnostic information can be displayed here and further adjustments can be made.

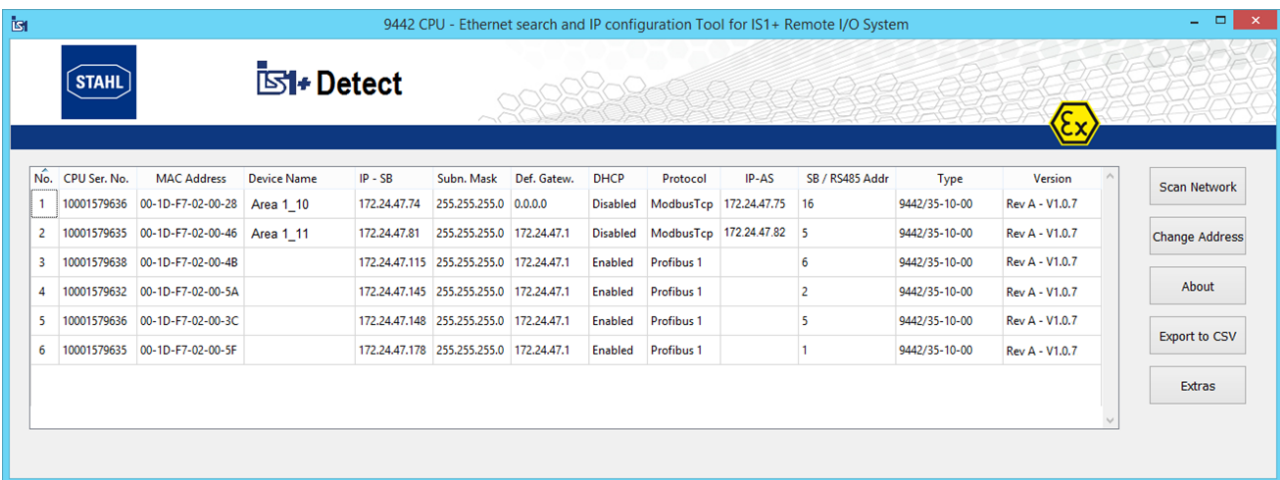

PROFINET interface description

2.8.3.3 IS1+ Web Server

The IP-AS address for the PROFINET interface and the IP-SB Address can be adjusted via the Web server of 9442 CPU optionally.

The IP-AS, IP-SB addresses and the Device Name of both CPUs (left - and right CPU) of a redundant pair are displayed in the IS1 Webserver while the Web server is connected with one of the two CPUs (connected).

The IP-SB as well as IP-AS address can only be changed in the CPU, with which the Web server is currently connected. A valid user login is required for change.

A manual change is only possible with a valid user login and without DataExchange with an MODBUS TCP client. DHCP must be disabled. An existing connection to the Web server is closed after a change of IP SB address and must be reopened to the modified IP SB address.

The screenshot shows the IS1+ Web Server interface with the following configuration details:

CPU 9442 - Left (connected)		CPU 9442 - Right	
Device Name: Station22.3		Device Name: -	
	IP-AS	IP-SB	
IP-Address:	172.24.47.75	172.24.47.74	IP-Address: 0.0.0.0
Subnet	255.255.255.0	255.255.255.0	Subnet 0.0.0.0
Default GW:	0.0.0.0	0.0.0.0	Default GW: 0.0.0.0
MAC Address:	00:1d:f7:02:00:28	00:1d:f7:02:00:2b	MAC Address: 00:00:00:00:00:00

IP Address change is disabled during AS Data Exchange.	Service Bus / RS485 Addr. 16
	AS Protocol PROFINET
	SB-DHCP <input type="button" value="Disable"/>

Warning! Use for authorized personal only! Changing address data during operation may cause loss of concerned ethernet communication connections.

PROFINET interface description

2.9 System start-up behavior

After power on the entire data range of the IS1+ internal output register is initialized with the value 0x8000. All output signals therefore remain in the safe setting.
The remaining data areas are initialized with 0x0000.

The IS1+ CPU remains in the state "No data exchange (after power on)", until Data Exchange is started by the IO controller.

The output signals remain in safe setting until valid output data (IOPS=Good) is written by the AS.

The start-up behavior of the cyclic communication between a PROFINET controller and a PROFINET slave (IS1+) is standardized and is handled automatically by the controller. During the start-up process, the PN controller and the IS1+ CPU automatically exchange information on data block length, structure of data blocks (assignment to modules), parameters

Changing I/O modules during operation is possible. After pull out of an I/O module and plugging in of a new module of the same module type, parameters are automatically transferred from IS1+ CPU to the I/O module, followed by an automatic restart of the I/O module. -> Hot swap I/O module.

Exception: Module TIM R 9480/.. : The calibration value for 2 wire operation is stored in the I/O module. After changing of I/O modules a new calibration is required.

PROFINET interface description

2.10 PROFINET functions

GSDML (Generic Station Description Markup Language) is used in PROFINET and has extended functionality compared to PROFIBUS GSD. GSDML is based on XML and supports data base structures. Compared to all other realized AS protocols of IS1 this enables a extended and more comfortable system integration.

Various details of IS1+ functions and 'Application Relations (AR)' are described in the GSDML and can be used automatically by the engineering system.

The 'PROFINET XML Viewer' tool is available from PNO for members which support a comfortable view of GSDML file contents.

Addressing was extended compared to PROFIBUS.

One Module can contain logical submodules. Each submodule can contain a group of signals. This is used with IS1+ e. g. in an AIM with one submodule containing 8 AI signals and separate submodules with HART variables.

This enables optional configuration of cyclic transmission of the HART variables to the AS.

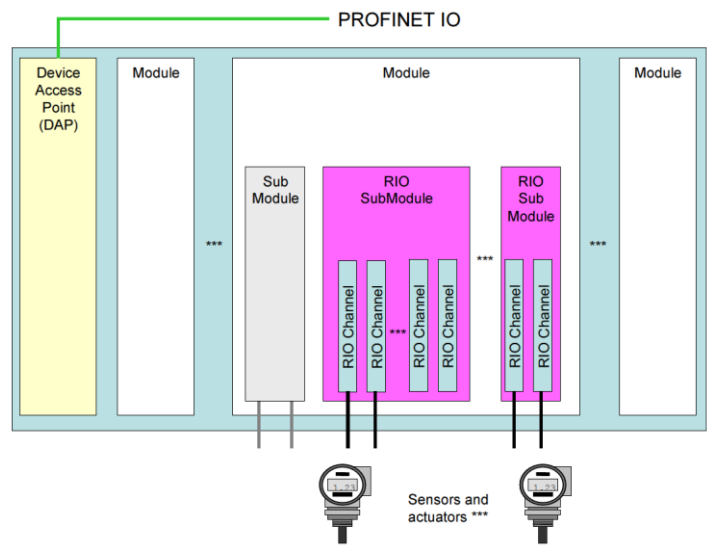

2.11 RIO Profile functions

Signal behavior, data formats and parameter of DI, DO, AI and AO signals are mapped by IS1+ according PNO Profile 'PROFINET RIO for PA', Doc. 3.232.

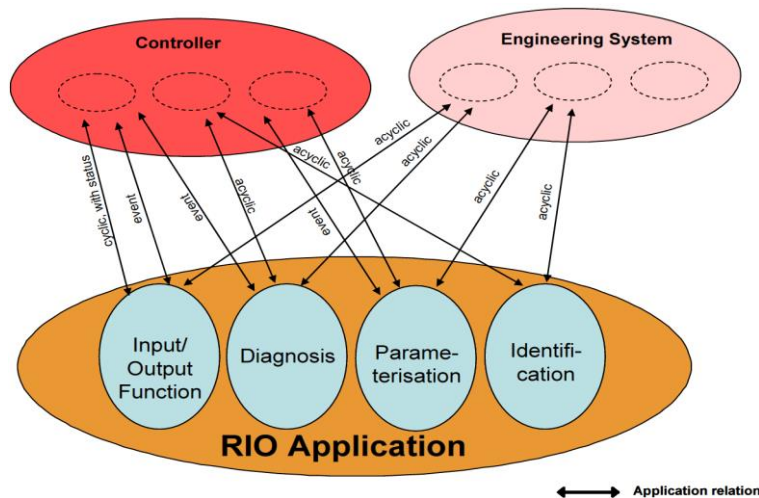

Device functions are mapped to Transducer- and Function Blocks and are partially similar to definitions of the PROFIBUS PA profile.

PROFINET interface description

Example: AI

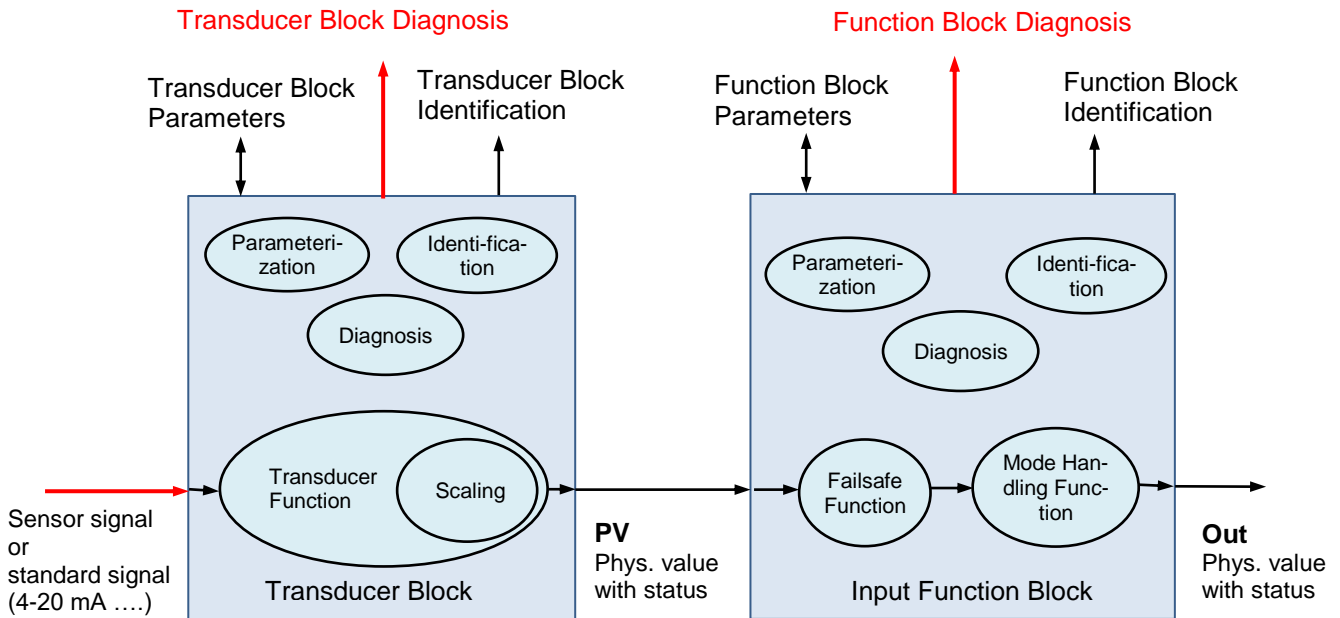

2.11.1 Mode handling

Attention!

Mode handling is prepared for all signal types but is actually not supported by 9442 CPU.

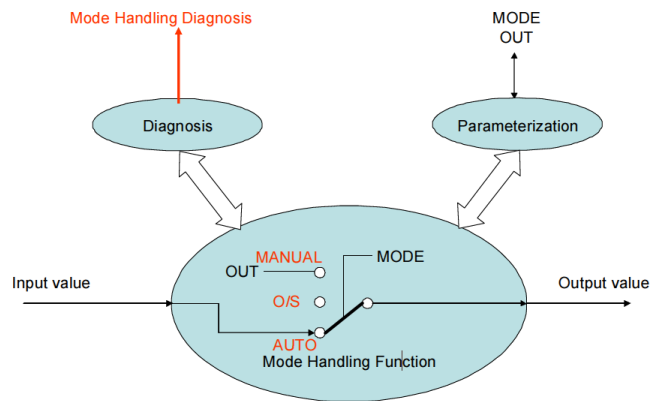

Name	Parameter	Description
AUTO	Default	In operation. Signal is available and updated cyclically
<i>MANUAL</i>	<i>Not supported</i>	Signal with Status can be written by the parameter 'Out'. *1)
<i>O/S (out of service)</i>		Signal is out of service. No diagnosis alarms. Status = bad, device passivated

*1) Writing FB Parameters according RIO for PA profile like e. g. Parameter 'Out' via acyclic data blocks is prepared in IS1 but not supported by actual tools.

PROFINET interface description

2.11.2 Signal inversion

Inversion (for DI only):

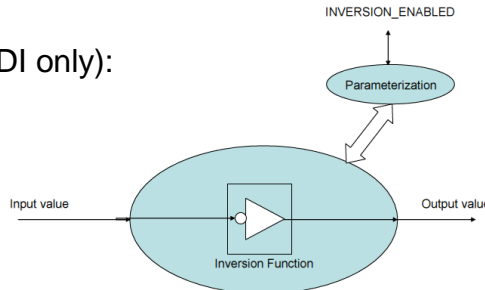

2.11.3 Scaling for AI and AO signals

Conversion of standard signals (e.g. 4 – 20 mA) to signals with physical unit (e.g. m³/h) is supported.

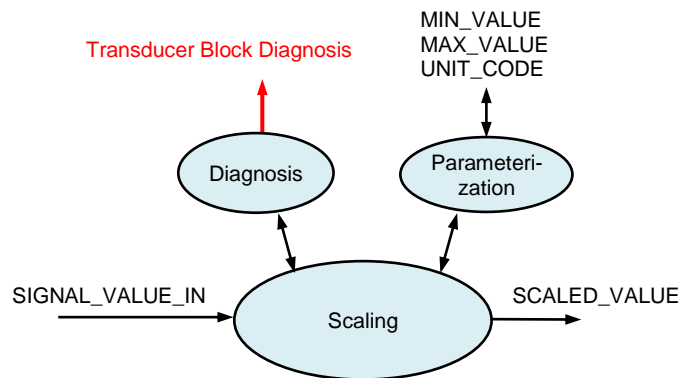

Fix scaling (Default):

In all cases of parameter UNIT_CODE **except** 'Textual Unit definition' like e. g. mA, °C, mV, Ohm, % ... the scaling factors are set internally of the IS1+ CPU and the value is scaled to the selected unit.

-> **Settings of the parameter MIN_VALUE, MAX_VALUE and UNIT_TEXT have no effect in this case.**

Free scaling:

For free scaling with use of the parameter MIN_VALUE and MAX_VALUE the parameter UNIT_CODE = 1995 'Textual Unit definition' must be set.

In this case any Unit string can be assigned as ASCII Text to parameter UNIT_TEXT. The settings of the parameter SIGNAL_TYPE respectively SENSOR_TYPE effect the measuring range (0% and 100%) where the scaling is based on.

Name	Description	Type
MIN_VALUE	The value in engineering units at 0% of the input signal (e.g. 4mA, 0V,...).	Float
MAX_VALUE	The value in engineering units at 100% of the input signal (e.g. 20mA, 10V, ..)	
UNIT_CODE	A code representing the Engineering Unit.	INT16
UNIT_TEXT	Any Unit string. In AS used if UNIT_CODE = 1995 (Textual Unit definition) only.	String 32
SIGNAL_VALUE_IN	The digital representation of the physical value with status information	INT16
SCALED_VALUE	The digital representation of the scaled physical value with status information. The status information is generated by the algorithm.	Float+Status
SIGNAL_MIN	The upper (100%) and lower (0%) values of measuring range of the standard signal, depending on the type of the signal (SIGNAL_TYPE or SENSOR_TYPE). For example, for a 4..20mA signal SIGNAL_MIN is 4 and SIGNAL_MAX is 20. See Data word structure of the I/O modules	-
SIGNAL_MAX		

PROFINET interface description

Scaling function:

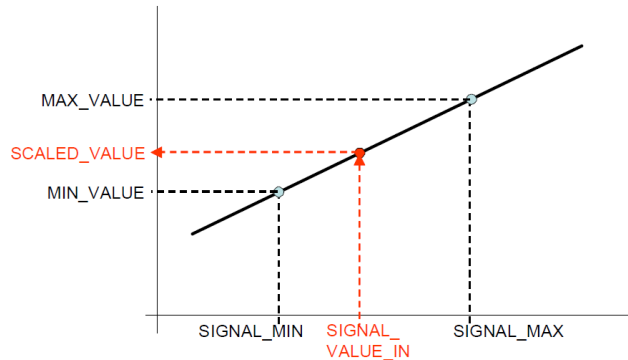

$$SCALED_VALUE = (SIGNAL_VALUE_IN - SIGNAL_MIN) \frac{(MAX_VALUE - MIN_VALUE)}{(SIGNAL_MAX - SIGNAL_MIN)} + MIN_VALUE$$

If scaling is used for AO signals, the scaling function is used inversely.

IOM Type	Measurement Range	0% (SIGNAL_MIN)	100% (SIGNAL_MAX)	Hint
AIM, AIMH 9460/.. , 9461/..	0-20 mA	0	20	
AOM , AOMH 9465/... , 9466/..	4-20 mA	4	20	
AUMH, UMH 9468/.., 9469/..				
TIM 9480/.. , 9481/.. , 9482/..	Temperature	-	-	°C or °F only
	Poti in Ohm 500 R	0	500 R	
	Poti in Ohm 2K5	0	2K5	
	Poti in Ohm 5K	0	5K	
	Poti in Ohm 10K	0	10K	
	Poti in %	0	100%	
	0 ... 100 mV	0	100 mV	
all DIM with Frequency measurement (9470/3x in compatible Mode):	1 Hz – 1 kHz	0	1000 Hz	
	x – 20 kHz	0	20000 Hz	
DIOM 9470/3x, 9471/35, 9472/35 (IS1+)	0,1 Hz – 600 Hz	0	600 Hz	100% = 400 Hz in I.S.Wizard + DTM
	1 Hz – 3 kHz	0	3000 Hz	100% = 2 kHz in I.S.Wizard + DTM
	1 Hz - 20 kHz	0	20000 Hz	

PROFINET interface description

Examples for common UNIT Codes:

UNIT	UNIT_CODE	Hint														
K	1000	-														
°C	1001															
°F	1002															
Hz	1077															
kHz	1081															
bar	1137															
mbar	1138															
mA	1211															
V	1240															
Ω	1281															
kΩ	1284															
Textual Unit definition	1995		<p>Any Unit can be allocated as ASCII Text in parameter UNIT_TEXT. In AS this string is used if UNIT_CODE = 1995 (Textual Unit definition) only. Parameter MIN_VALUE und MAX_VALUE shall be used for definition of the conversion factor in this case. The use of 'Visible exchange format' (PNO Doc. 3.512 or ISO/IEC 10646) is recommended.</p> <p>Examples for Visible exchange format:</p> <table style="margin-left: 40px;"> <tr> <td>m³/min</td> <td>= m**3/min</td> </tr> <tr> <td>l/s</td> <td>= l/s</td> </tr> <tr> <td>°C</td> <td>= C</td> </tr> <tr> <td>°F</td> <td>= F</td> </tr> <tr> <td>Ω</td> <td>= O</td> </tr> <tr> <td>kΩ</td> <td>= kO</td> </tr> <tr> <td>°C</td> <td>= C</td> </tr> </table>	m ³ /min	= m**3/min	l/s	= l/s	°C	= C	°F	= F	Ω	= O	kΩ	= kO	°C
m ³ /min	= m**3/min															
l/s	= l/s															
°C	= C															
°F	= F															
Ω	= O															
kΩ	= kO															
°C	= C															

2.11.4 Failsafe Function

Parameter Name	Selection		
	AI	AO	DI / DO
FAILSAFE_TYPE	freeze (USE_LAST_VALID_VALUE)		
	-10%, 0%, 100%,	-10% (for live Zero only) 0%, 100%, 110%	0 1
FAILSAFE_TIME	IS1 global CPU parameter: Failsafe time output modules (x100 ms)		

PROFINET interface description

2.11.4.1 Behavior of the input signals in case of errors

If no valid signal value can be formed as a result of a malfunction (short circuit, open circuit, defective sub-assembly...), an alarm message is transmitted to the AS and diagnostics information is created which can be read via the AS or the engineering system. Despite the outstanding malfunction, cyclic data including signal status information continues to be transmitted to the AS.

The input signals adopt the safe state according to the settings of Failsafe Function and the error is indicated in signal status.

2.11.4.2 Behavior of the output signals in case of errors

Communication error between the host and IS1+ field station:

The cyclic data traffic between the PROFINET host and IS1+ is checked in the IS1+ CPU.

In case of communication loss to the PROFINET controller or if the output data are marked as invalid by the PROFINET controller (IOPS = Bad), the outputs of the I/O modules are set to the safe state according to the settings of the 'Failsafe Function' parameter.

Communication error between the CPU and output module:

There are watchdog circuits on the output modules that monitor the data transmission between the CPU and the output modules. If an output module does not receive any valid data for more than T_{Mod} (Parameter 'Failsafe time output modules'), the outputs adopt the safe state according to the settings of Failsafe Function.

T_{Mod} can be set as CPM parameter 'Failsafe time output modules' global for each IS1+ field station in the range 100 ms to 25.5 sec. (default value: 100 ms).

Signal status

Depending on the CPU parameter 'Ignore Output Signal Status' output signals with signal status unequal = OK can be set to safe state according to the settings of Failsafe Function.

See [Analog format with status according PI specification](#)

2.12 Module revision mapping

CPU	Revision	STAHL	PN	Example	
				STAHL	PN
all	HW- Rev.	Rev. A, B, C	1, 2, 3,	Rev. G	7
9441	FW- Rev.	uv-wx	V uv.wx.yz	02-40	V2.4.0
9442		uv-wx	V u.v.wx	10-07	V1.0.7

PROFINET interface description

3 Data traffic

3.1 Parameterization

3.1.1 CPU parameters

Parameter Group	Parameter	Default value	Value range / selection
CPU parameter	Failsafe time output modules (x 100 ms) *1)	1	Unsigned 8 (1 - 255)
	PM Redundant *2)	No	No Yes
	Ignore Output Signal Status *3)	Enabled	0 = Disabled 1 = Enabled

*1) see [Behavior of the output signals in case of errors](#)

*2) 9442 CPU with 9445 Power Module only

*3) 9442 CPU from FW V1.0.16 and GSDML-V2.33-Stahl-RIO9442-20190903.xml
 Details see [Analog format with status according PI specification](#)

PROFINET interface description

3.1.2 I/O module parameters

3.1.2.1 AIM / AIMH 9461

Module parameter

Parameter Group	Parameter	Default value	Value range / selection
Manufacturer specific	Input Filter	Medium	small medium big (50 Hz) big (60 Hz)
	Scan HART livelist (only for AIMH)	On	Off On

Signal parameter

Manufacturer specific	Failsafe type	0 %	-10 % (4 mA only) 0 % 100 % freeze (initial value 0%) freeze (initial value 100%)
	Measurement range ac. NAMUR	No	No Yes
Mode channel x	Mode	AUTO	AUTO (MANUAL - not supported) (OUT OF SERVICE – not supported)
Channel x alarm disabled	Channel alarm disabled	False	True False
Output function block channel x	value	0	Value in Engineering Unit
	status	128 (0x80) = OK	128 (0x80) = OK unequal 128 = disturbed
Scaling channel x	MIN_VALUE	4	See Scaling for AI and AO signals . Changed values are used for scaling in case of UNIT_CODE = 1995 only.
	MAX_VALUE	20	
	UNIT_CODE	mA	1211 (mA) 1995 Textual Unit definition
	UNIT_TEXT	mA	Any Unit string. In AS used if UNIT_CODE = 1995 (Textual Unit definition) only
Config channel x	SIGNAL_TYPE	4...20 mA	0...20 mA 4...20 mA

HART 8 - Mapping HART Variables in Submodule 2

HART variable pos. 1	HART channel	Not used	0...7 Not used
	HART variable	2	1 - 4
		
HART variable pos. 8	HART channel	Not used	0...7 Not used
	HART variable	2	1 - 4

PROFINET interface description

3.1.2.2 AUMH 9468

Module parameter

Parameter Group	Parameter	Default value	Value range / selection
Manufacturer specific	Input Filter	Medium	Small Medium Big (50 Hz) Big (60 Hz)
	Scan HART livelist (only for AIMH)	On	Off On

Signal parameter

Manufacturer specific	Failsafe type	0 %	-10 % (4 mA only) 0 % 100 % freeze (initial value 0%) freeze (initial value 100%)
	Measurement range ac. NAMUR *1)	No	No Yes
	I/O type	Analog Input	Input Output
Mode channel x	Mode	AUTO	AUTO (MANUAL - not supported) (OUT OF SERVICE – not supported)
Channel x alarm disabled	Channel alarm disabled	False	True False
Output function block channel x	value	0	Value in Engineering Unit
	status	128 (0x80) = OK	128 (0x80) = OK < 128 = disturbed
Scaling channel x	MIN_VALUE	4	See Scaling for AI and AO signals . Changed values are used for scaling in case of UNIT_CODE = 1995 only.
	MAX_VALUE	20	
	UNIT_CODE	mA	1211 (mA) 1995 Textual Unit definition
	UNIT_TEXT	mA	Any Unit string.
Config channel x	SIGNAL_TYPE	4...20 mA	0...20 mA 4...20 mA

- *1) The parameters 'Measurement range ac. NAMUR' are valid only for Input Signals !
The parameters are visible for all switchable AI/AO Signals but are without effect for the AO signals.

HART 8 - Mapping HART Variables in Submodule 2

HART variable pos. 1	HART channel	Not used	0...7 Not used
	HART variable	2	1 - 4
		
HART variable pos. 8	HART channel	Not used	0...7 Not used
	HART variable	2	1 - 4

PROFINET interface description

3.1.2.3 UMH 9469

Modul Parameter

Parameter Group	Parameter	Default value	Value range / selection
Manufacturer specific	Input Filter	Medium	Small Medium Big (50 Hz) Big (60 Hz)
	Scan HART livelist	On	Off On
	Namur Limits *1)	No	No Yes
	Input/Output Range	4...20 mA	0...20 mA 4...20 mA
	DI Pulse extension 1,2 s	Off	Off On

Signal Parameter

Manufacturer specific	Failsafe type	0 %	-10 % (4 mA only) 0 % 100 % freeze (initial value 0%) freeze (initial value 100%)
	I/O type	Input	Input Output
	SIGNAL_TYPE	2 wire analog in/out	- 2 wire analog in/out - 3/4 wire analog in *2) - 2/3 wire digital in/out *2)
Mode channel x	Mode	AUTO	AUTO (MANUAL - not supported) (OUT OF SERVICE – not supported)
Channel x alarm disabled	Channel alarm disabled	False	True False
Output function block channel x	value	0	Value in Engineering Unit
	status	128 (0x80) = OK	128 (0x80) = OK < 128 = disturbed
Scaling channel x	MIN_VALUE	4	Changed values are used for scaling in case of UNIT_CODE = 1995 only. see Scaling for AI and AO signals
	MAX_VALUE	20	
	UNIT_CODE	mA	1211 (mA) 1995 Textual Unit definition
	UNIT_TEXT	mA	Any UNIT String.

*1) The parameter Namur Limits (Measurement range ac. NAMUR) is functional for Analog Input Signals only!

*2) 3/4 wire analog in and 2/3 wire digital in/out are available for channel 4 to 7 only.

PROFINET interface description

HART 8 - Mapping HART Variables in Submodule 2

Parameter Group	Parameter	Default value	Value range / selection
HART variable pos. 1	HART channel	<i>Not used</i>	0...7 <i>Not used</i>
	HART variable	2	1 - 4
		
HART variable pos. 8	HART channel	<i>Not used</i>	0...7 <i>Not used</i>
	HART variable	2	1 - 4

PROFINET interface description

3.1.2.4 TIMR 9480

Module parameter

Parameter Group	Parameter	Default value	Value range / selection
Manufacturer specific	Input Filter	50 Hz	50 Hz 60 Hz Off (not recommended)
	Operation mode	8 inputs	8 inputs 2 inputs

Signal parameter

Manufacturer specific	Failsafe type	freeze	freeze (initialization value 0%)
	Connection	4 wire measure (Pot in Ohm)	2 wire measure (Pot in Ohm) 3 wire measure (Pot in %) 4 wire measure (Pot in Ohm)
	Sensor type	Pt100	Pt100 Pt500 Pt1000 Ni100 Ni500 Ni1000 Resistance (Pot) 10k Resistance (Pot) 5k Resistance (Pot) 2k5 Resistance (Pot) 500R Pt100 GOST } from Fw. V02-04 M50 GOST } M100 GOST } Cu53 GOST } from Fw. V02-05 Pt46 GOST } Pt50 GOST }
Mode channel x	Mode	AUTO	AUTO (MANUAL - not supported) (OUT OF SERVICE – not supported)
Channel x alarm disabled	Channel alarm disabled	False	True False
Output function block channel x	value	0	Value in Engineering Unit
	status	128 (0x80) = OK	128 (0x80) = OK unequal 128 = disturbed

PROFINET interface description

Parameter Group	Parameter	Default value	Value range / selection		
Scaling channel x	MIN_VALUE	-200	See Scaling for AI and AO signals . Changed values are used for scaling in case of UNIT_CODE = 1995 only.		
	MAX_VALUE	850			
	UNIT_CODE *1)			Unit	allowed Type
		°C		1001 °C 1002 °F	all temperature sensors
		Ω		1281 Ω 1284 kΩ	Resistance (Pot) 2 wire or 4 wire m. (Pot in Ohm)
		%		1342 %	Resistance (Pot) 3 wire measure (Pot in %)
	-		1995 Textual Unit definition	All types except temp. sensors	
UNIT_TEXT		mA	Any Unit string. In AS used if UNIT_CODE = 1995 (Textual Unit definition) only		

*1) **Note:** Allowed unit codes depend on settings of parameter 'Sensor Type' and in case of Resistance (Pot) measurement additional on parameter 'Connection'. The selected unit code will be ignored in case of not allowed combinations, and the default unit with default scaling for the selected Sensor Type will be used.

PROFINET interface description

3.1.2.5 TIM mV 9481

Module parameter

Parameter Group	Parameter	Default value	Value range / selection
Manufacturer specific	Input Filter	50 Hz	50 Hz 60 Hz

Signal parameter

Manufacturer specific	Failsafe type	freeze	freeze (initialization value 0%)	
	Input signal	Balanced	Balanced Unbalanced	
	Sensor type	THC Type K	0...100 mV THC Type B THC Type E THC Type J THC Type K THC Type N THC Type R THC Type S THC Type T THC Type L THC Type U THC Type XK (L)	
Mode channel x	Mode	AUTO	AUTO (MANUAL - not supported) (OUT OF SERVICE – not supported)	
Channel x alarm disabled	Channel alarm disabled	False	True False	
Output function block channel x	value	0	Value in Engineering Unit	
	status	128 (0x80) = OK	128 (0x80) = OK unequal 128 = disturbed	
Scaling channel x	MIN_VALUE	-200	See Scaling for AI and AO signals . Changed values are used for scaling in case of UNIT_CODE = 1995 only.	
	MAX_VALUE	1370		
	UNIT_CODE	°C	Unit	allowed Type
			1001 °C 1002 °F	all THC sensors
			1243 mV 1995 textual Unit definition	0...100 mV
UNIT_TEXT	C	Any Unit string. In AS used if UNIT_CODE = 1995 (Textual Unit definition) only		

PROFINET interface description

3.1.2.6 TIM 9482

Module parameter

Parameter Group	Parameter	Default value	Value range / selection
Manufacturer specific-	Operation mode	8 channel precise	8 channel precise 4 channel fast
	TC cold junction	Internal	Internal External 3 wire
	Type TC external cold junction I6-I7	PT100	PT100 PT1000 PT100 GOST

Signal parameter

Manufacturer specific	Failsafe type	freeze	freeze (initialization value 0%)
	Connection	4 wire measure (Pot in Ohm)	2 wire measure (Pot in Ohm) 3 wire measure (Pot in %) 4 wire measure (Pot in Ohm) 4 wire measure (Pot in %)
	Sensor type	Pt100	Pt100 Pt500 Pt1000 Ni100 Ni500 Ni1000 Resistance (Pot) 10k Resistance (Pot) 5k Resistance (Pot) 2k5 Resistance (Pot) 500R Pt100 GOST M50 GOST M100 GOST Cu53 GOST Pt46 GOST Pt50 GOST 0...100 mV THC Type B THC Type E THC Type J THC Type K THC Type N THC Type R THC Type S THC Type T THC Type L THC Type U THC Type XK (L)
Mode channel x	Mode	AUTO	AUTO (MANUAL - not supported) (OUT OF SERVICE – not supported)
Channel x alarm disabled	Channel alarm disabled	False	True False
Output function block channel x	value	0	Value in Engineering Unit
	status	128 (0x80) = OK	128 (0x80) = OK unequal 128 = disturbed

PROFINET interface description

Parameter Group	Parameter	Default value	Value range / selection		
Scaling channel x	MIN_VALUE	-200	See Scaling for AI and AO signals . Changed values are used for scaling in case of UNIT_CODE = 1995 only.		
	MAX_VALUE	1370			
	UNIT_CODE *1)			Unit	allowed Type
		°C		1001 °C 1002 °F	all THC and temp. sensors
		mV		1243 mV	0...100 mV,
		Ω		1281 Ω 1284 kΩ	Resistance (Pot) 2 wire or 4 wire measure (Pot in Ohm)
		%		1342 %	Resistance (Pot) 3 wire or 4 wire measure (Pot in %)
	-		1995 textual Unit definition	All types except THC and temp. sensors	
UNIT_TEXT	C	Any Unit string. In AS used if UNIT_CODE = 1995 (Textual Unit definition) only			

*1) **Note:** Allowed unit codes depend on settings of parameter 'Sensor Type' and in case of Resistance (Pot) measurement additional on parameter 'Connection'. The selected unit code will be ignored in case of not allowed combinations, and the default unit with default scaling for the selected Sensor Type will be used.

PROFINET interface description

3.1.2.7 DIM (9470/3x in compatible mode)

Module parameter

Parameter Group	Parameter	Default value	Value range / selection
-	-	-	-

Signal parameter

Manufacturer specific	Failsafe type	0 %	0 1 freeze (initial value 0) freeze (initial value 1)
	Pulse extension	0 s	0 s 0.6 s 1.2 s 2.4 s
Mode channel x	Mode	AUTO	AUTO (MANUAL - not supported) (OUT OF SERVICE - not supported)
Channel x alarm disabled	Channel alarm disabled	False	True False
Output function block channel x	value	0	0, 1
	status	32 (0x20) = OK	32 (0x20) = OK unequal 32 = disturbed
Invert channel x	Inversion	False	True False

Counter Frequency 2 chan - Parameter Submodule 2

Count./Freq. config. chan. 14	Operation mode	Freq. 0-1 kHz / DI	Counter Freq. 0-1 kHz / DI Freq. 0-20 kHz gate 50 ms / DI Freq. 0-20 kHz gate 200 ms / DI Freq. 0-20 kHz gate 1 s / DI
	Counting event	Positive edge	Positive edge Negative edge
Count./Freq. config. chan. 15	s. a.		

Scaling channel 14	MIN_VALUE	0	See Scaling for AI and AO signals . Changed values are used for scaling in case of UNIT_CODE = 1995 only.	
	MAX_VALUE	1000		
	UNIT_CODE	Hz	Unit	allowed mode
			1077 Hz 1081 kHz 1995 textual Unit definition	Counter Frequency
UNIT_TEXT	Hz	Any Unit string. In AS used if UNIT_CODE = 1995 (Textual Unit definition) only		
Scaling channel 15	s. a.			

PROFINET interface description

3.1.2.8 DIOM 9470/3x, 9471/35, 9472/35 (IS1+)

Module parameter

Parameter Group	Parameter	Default value	Value range / selection
-	-	-	-

Signal / Signal pair parameter

Manufacturer specific	Failsafe type	0 %	0 1 freeze (initial value 0) freeze (initial value 1)
	Pulse extension / Filter chan. x, x+1 *2)	0 s	0 s / Off 0,6 s / Small 1,2 s / Medium 2,4 s / Large
	I/O type channel x, x+1	Input	9470/3x 9471/35, 9472/35 Input Output NAMUR Ini/ contact 3-wire Initiator PNP Output
Mode channel x	Mode	AUTO	AUTO (MANUAL - not supported) (OUT OF SERVICE – not supported)
Channel x alarm disabled	Channel alarm disabled	False	True False
Output function block channel x	value	0	0, 1
	status	32 (0x20) = OK	32 (0x20) = OK < 32 = disturbed
Invert chann.x, x+1	Inversion (for DI signals only)	False	True False

Counter 8 chan - Parameter Submodule 2

Count./Freq. config. chan. 8+9 chan. 10+11 chan. 12+13 chan. 14+15	Operation mode	Freq. 1 Hz - 3 kHz (0,05Hz/Bit)	0 = Counter 16 Bit 1 = Freq. 0,1 - 600 Hz (0,01Hz/Bit) 2 = Freq. 1 Hz - 3 kHz (0,05Hz/Bit) 3 = Freq. 1 Hz - 20 kHz (0,5Hz/Bit) 4 = Up/Down Counter 16 Bit 5 = Up/Down Counter 32 Bit 6 = Freq. 1 Hz - 20 kHz with direction
	Counting event	Positive edge	Positive edge Negative edge

Scaling chan. 8 chan. 9 . . . chan. 14 chan. 15	MIN_VALUE	0	See Scaling for AI and AO signals . Changed values are used for scaling in case of UNIT_CODE = 1995 only.	
	MAX_VALUE	2000		
	UNIT_CODE	Hz	Unit 1077 Hz 1081 kHz 1995 textual Unit definition	allowed mode Frequency Counter 16 Counter 32 *1)
	UNIT_TEXT	Hz	Any Unit string. In AS used if UNIT_CODE = 1995 (Textual Unit definition) only	

*1) Scaling parameter of fist channel of a pair are used for scaling.

*2) Filter nur bei Frequenz Messung wirksam, Impulsverl. nur bei DI/Zähler wirksam.

PROFINET interface description

3.1.2.9 AOM / AOMH 9466

Module parameter

Parameter Group	Parameter	Default value	Value range / selection
Manufacturer specific	Scan HART livelist (only for AIMH)	On	Off On

Signal parameter

Manufacturer specific	Failsafe type	0 %	-10 % (4 mA only) 0 % 100 % 110 % freeze
Mode channel x	Mode	AUTO	AUTO (MANUAL - not supported) (OUT OF SERVICE – not supported)
Channel x alarm disabled	Channel alarm disabled	False	True False
Output function block channel x	value	0	Value in Engineering Unit
	status	128 (0x80) = OK	128 (0x80) = OK < 128 = disturbed
Scaling channel x	MIN_VALUE	4	See Scaling for AI and AO signals . Changed values are used for scaling in case of UNIT_CODE = 1995 only.
	MAX_VALUE	20	
	UNIT_CODE	mA	1211 (mA) 1995 Textual Unit definition
	UNIT_TEXT	mA	Any Unit string. In AS used if UNIT_CODE = 1995 (Textual Unit definition) only
Config channel x	SIGNAL_TYPE	4...20 mA	0...20 mA 4...20 mA

HART 8 - Mapping HART Variables in Submodule 2

HART variable pos. 1	HART channel	Not used	0...7 Not used
	HART variable	2	1 - 4
		
HART variable pos. 8	HART channel	Not used	0...7 Not used
	HART variable	2	1 - 4

PROFINET interface description

3.1.2.10 DOM

Module parameter

Parameter Group	Parameter	Default value	Value range / selection
-	-	-	-

Signal parameter

Manufacturer specific	Failsafe type channel x	0	0 1 freeze
Mode channel x	Mode	AUTO	AUTO (MANUAL - not supported) (OUT OF SERVICE – not supported)
Channel x alarm disabled	Channel alarm disabled (not available for DOMR and DOMV)	False	True False (without test current) False
Output function block channel x	value	0	0, 1
	status	32 (0x20) = OK	32 (0x20) = OK < 32 = disturbed

Signal Pair parameter S0+1, S2+3, S4+5, S6+7

Manufacturer specific	Output 0 and 1 parallel	Outputs separate	Outputs separate Outputs parallel
	...		
	Output 6 and 7 parallel		

PROFINET interface description

3.2 Data word structure of the I/O modules

3.2.1 Analogue modules

Analogue signals are exchanged between the IS1+ field station and an automation system in floating point format + Status. Converting to and from floating point variables (physical values) is performed in the IS1 system (see [Scaling for AI and AO signals](#)).

AIM, AIMH (9460/..., 9461/..., 9468/..., 9469/...)
0 – 20 mA

Measuring range 0 – 20 mA	Internal digital value		%	Parameter: Measurement range limits according NAMUR	Range	Diagnosis messages
	Decimal	Hex				
>23.518 mA >21 mA	*1)	*1)		No Yes		Short circuit
23.518 mA 21 mA	32511 29030	7EFF 7166	117.6% 105 %	No Yes	Over range	-
20 mA 10 mA 0 mA	27648 13824 0	6C00 3600 0	100% 50% 0%		Nominal range	-
< 0 mA	0	0	0%			

AIM 4 – 20 mA

Measuring range 4 – 20 mA	Internal digital value		%	Parameter: Measurement range limits according NAMUR	Range	Diagnosis messages
	Decimal	Hex				
>22.814 mA >21 mA	*1)	*1)		No Yes		Short circuit
22.814 mA 21 mA	32511 29376	7EFF 72C0	117.6% 106,25 %	No Yes	Over range	-
20 mA 12 mA 4 mA	27648 13824 0	6C00 3600 0	100% 50% 0%		Nominal range	-
3.999 mA 3,6 mA 2.4 mA	-1 -691 -2765	FFFF FD4D F533	 -2,5% -10%	 Yes No	Under range	-
< 3,6 mA < 2.4 mA	*1)	*1)		Yes No		Line break

*1) an internal status code is generated in case of error

Measurement range limits according NAMUR:

The limits of the measurement range to the short circuit and open circuit area can be modified by the parameter 'Measurement range limits according NAMUR' according the above table.

For 9468 AUMH the parameters 'Measurement range ac. NAMUR' are valid for Input Signals only!

The parameters are visible for all switchable AI/AO Signals but are without effect for the AO signals.

PROFINET interface description

Data word structure cyclic analog data

Data	Byte	Module / Operating mode				Sub-slot	Var. Type	Signals	
		AIM 9460/..., AIMH 9461		AUMH 9468/..., UMH 9469/...					
		8AI	8AI+8HV	8AI/8AO	8AI/8AO+8HV				
Input	1 – 5	AI0	AI0	AI0	AI0	1	Float 32 + Status DSARIO1	Analog Input Signals AI0 – AI7 or AO readback	
	6 – 10	AI1	AI1	AI1	AI1				
	11 – 15	AI2	AI2	AI2	AI2				
	16 – 20	AI3	AI3	AI3	AI3				
	21 – 25	AI4	AI4	AI4	AI4				
	26 – 30	AI5	AI5	AI5	AI5				
	31 – 35	AI6	AI6	AI6	AI6				
	36 – 40	AI7	AI7	AI7	AI7				
		1 – 4		HV-P1		HV-P1	2	Float 32	HART Variables transmitted on positions P1 - P8
		5 – 8		HV-P2		HV-P2			
		9 – 12		HV-P3		HV-P3			
		13 – 16		HV-P4		HV-P4			
		17 – 20	-	HV-P5	-	HV-P5			
		21 – 24		HV-P6		HV-P6			
		25 – 28		HV-P7		HV-P7			
	29 – 32		HV-P8		HV-P8				
Output	1 – 5			AO0	AO0	1	Float 32 + Status DSARIO1	Analog Output Signals AO 0 – AO 7	
	6 – 10			AO1	AO1				
	11 – 15			AO2	AO2				
	16 – 20			AO3	AO3				
	21 – 25			AO4	AO4				
	26 – 30			AO5	AO5				
	31 – 35			AO6	AO6				
	36 – 40			AO7	AO7				

Readback:

For all channels parameterized as AO the written output value can be read via the associated AI signal (Readback). Using channel parameterization as AI written dedicated AO signal has no effect.

Data word structure 9469

Selection for channels 4 to 7 of the UMH 9469 module using parameter 'connection' and 'I/O type':

- 2 wire analog in/out
- 3/4 wire analog in
- digital in/out

Via Profinet, 5 bytes per signal are always transmitted independently of this.

The data type DSDRIO1 is not used for digital values with 9469. This applies here:

Parameter 'Connection' and 'I/O type'	Data format
2 wire analog in/out	Float + Status (Analog Format DSARIO1)
3/4 wire analog in	
Digital in/out	U32 + Status Example: U32 = 16#0000_0001 = 1

PROFINET interface description

3.2.1.1 Analog format with status according PI specification

Datatype DSARIO1: (data type numerical identifier 0x105)

Value	Status							
Byte 1 – 4	Byte 5							
-	Bit7	Bit6	Bit5	Bit4	Bit3	Bit2	Bit1	Bit0
Float 32	Status value according PI						0	0

Status	Possible causes	Status value		NE107	
		(upper 6 Bit)	8 Bit		
GOOD_OK	-	32 0x20	128 0x80	No Error	
GOOD_MAINT_REQ	IOM_ALARM_BUS_PRIM, IOM_ALARM_BUS_RED, CHAN_DIAG_OVERTEMP	41 0x29	164 0xA4	Maintenance required	
UNCERT_NoMAINT	CHAN_DIAG_UPP_LIM_EXCEED, CHAN_DIAG_LOW_LIM_EXCEED	30 0x1E	120 0x78	Out of spec.	
BAD_MAINTAlarm	BAD_CONF_ERROR: IOM_ALARM_CONFIG	9 0x09	36 0x24	Failure	
	BAD_DEV_FAILURE: IOM_ALARM_HW_ERR, IOM_ALARM_WRONG, CHAN_ALARM_ERR				
	BAD_SENSOR_FAIL: CHAN_ALARM_SC (Short), CHAN_ALARM_LB (Line Break)				
	BAD_OUT_OF_SERV				
	BAD_OUT_STATUS *1)				

*1) The effectiveness of the signal status of output signals can be selected via the CPU parameter 'Ignore Output Signal Status'.

CPU Parameter 'Ignore Output Signal Status'	Function
Disabled	Output signals with signal status unequal OK will adopt failsafe position and deliver readback status = bad.
Enabled	Output signals are always operated regardless of the signal status and only enter the safety position if the cyclic connection is lost (IOCS=Bad, WD_TIME_EXCEEDED) or in case of Device Failure or Config Error. The readback status is independent of the signal status and only becomes Bad in case of signal or module error.

The upper 6 Bit of the Status byte contain the Status information. Bit 0 and Bit 1 are always zero for analog values. Digital signals use this bits for signal information (see data type DSDRIO1).

Status Information according NAMUR NE107 is intended to give the operator a fast and easy overview about the quality of a signal without details of the fault reason. PI status definitions (condensed status) support predictive and preventive maintenance.

Details for maintenance people are reported in [Alarm- and diagnosis data](#).

PROFINET interface description

TIM (9480/.. , 9481/.. , 9482/..)

Temperature measurement (1 Digit = 0,1 °C)

Temperature	Internal digital value		Range	Diagnosis messages
	Decimal	hexadecimal		
	*1)	*1)		Line break / Upper limit exceeded
*2) 1000 °C	*2) 10000	*2) 2710	Temperature measurement range	
1 °C	10	000A		
0 °C	0	0		
-0,1 °C	-1	FFFF		
-100 °C	-1000	FC18		
*2)	*2)	*2)		Lower limit exceeded / short circuit
	*1)	*1)		

*1) an internal status code is generated in case of error

*2) The limits of the measurement range are pending on the parameterized input type (see Operating instructions IS1)

2 wire and 4 wire Resistance Measurement Pot in Ohm 500 R ...10K (module 9480 /.. , 9482/..)

Range				Internal digital value		%	Range	Diagnosis messages
500 R	2 K 5	5 K	10 K	decimal	hexadecimal			
>588 R	>2,94 K	> 5,88K	>11,76 K	*1)	*1)			Line break
588 R	2,94 K	5,88 K	11,76 K	32511	7EFF	117,6%	Over range	-
500 R	2 K 5	5 K	10 K	27648	6C00	100%	Nominal range	-
250 R	1K250	2K5	5 K	13824	3600	50%		
0 K	0 K	0 K	0 K	0	0	0%		

3 wire and 4 wire Resistance Position Measurement Pot in % 500 R...10K (module 9480/.. , 9482/..)

Range				Internal digital value		%	Range	Diagnosis messages
500R	2K5	5 K	10 K	decimal	hexadecimal			
>588 R	>2,94 K	>5,88 K	>11,76K	*1)	*1)			Line break
position 100 %				27648	6C00	100%	Nominal range	-
position 50 %				13824	3600	50%		
position 0 %				0	0	0%		
< 50 R	< 250 R	< 500 R	< 1 K	*1)	*1)			short circuit

0,02 R	0,1 R	0,2 R	0,4 R	Resolution per Digit
--------	-------	-------	-------	----------------------

Hint: 9480 supports no 4 wire Resistance Position Measurement in %.

PROFINET interface description

0 ... 100 mV measurement (9481/.., 9482/..)

Range 0 ... 100 mV	Internal digital value		%	Range	Diagnosis messages
	decimal	hexadecimal			
>117,6 mV	*1)	*1)			Upper limit exceeded
117,6 mV	32511	7EFF	117,6 %	Over range	-
100 mV	27648	6C00	100 %	Nominal range	-
50 mV	13824	3600	50 %		
0 mV	0	0	0 %		
-0,0036 mV	-1	FFFF		Under range	-
-10 mV	-2765	F533	-10 %	(9481/..)	
-117,6 mV	-32511	8101	-117,6%	(9482/..)	
<	*1)	*1)			Lower limit exceeded

*1) an internal status code is generated in case of error

Short circuit alarm cannot be detected at Resistance and Voltage measurement!

An automatic 2 wire calibration function of the TIM 9482 /... can be used optionally, see operating instructions 9482.

Data word structure cyclic analog data TIM 9480, 9481, 9482

Data	Byte	Module TIM 9480, 9481, 9482	Sub- slot	Var. Type	Signals
		8AI			
Input	1 – 5	AI0	1	Float 32 + Status DSARIO1	Analog Input Signals AI0 – AI7
	6 – 10	AI1			
	11 – 15	AI2			
	16 – 20	AI3			
	21 – 25	AI4			
	26 – 30	AI5			
	31 – 35	AI6			
	36 – 40	AI7			

PROFINET interface description

AOM 0 – 20 mA (9465/... , 9466/..., 9468/..)

Measuring range 0 – 20 mA	Internal digital value		%	Range
	Decimal	Hexadecimal		
*1)	>30137	>75B9		
21,8 mA	30137	75B9	109%	Over range
.	.	.		
20 mA	27648	6C00	100%	Nominal range
.	.	.		
10 mA	13824	3600	50%	
.	.	.		
0 mA	0	0	0%	
0 mA	< 0	< 0		

AOM 4 – 20 mA

Measuring range 4 – 20 mA	Internal digital value		%	Range
	Decimal	Hexadecimal		
*1)	>30759	>7827		
21,8 mA	30759	7827	111,25%	Over range
.	.	.		
20 mA	27648	6C00	100%	Nominal range
.	.	.		
12 mA	13824	3600	50%	
.	.	.		
4 mA	0	0	0%	
3,999 mA	-1	FFFF		Under range
0 mA	-6912	E500	-25%	
0 mA	< -6912	< E500		

*1) : The AOM attempts to increase the current further according to the control value. However, depending on the burden effective resistance, the maximum output voltage of the AOM may be reached whereby the current can no longer be increased.

Safety position after Power On:

After Power On of the CPU the internal data area of the outputs is initialized with the value -32768 (0x8000) as signal for the safety position.

The outputs remain in the save position as long as the allocated register is overwritten with a valid output value (<> -32768 (0x8000))

PROFINET interface description

Data word structure cyclic analog data AOM 9465/..., AOMH 9466/...

Data	Byte	Operation mode		Subslot	Var. Type	Signals
		8AO	8AO+8HV			
Input	1 – 5	AOR 0	AOR 0	1	Float 32 + Status DSARIO1	Readback with Status AO 0 – AO 7
	6 – 10	AOR 1	AOR 1			
	11 – 15	AOR 2	AOR 2			
	16 – 20	AOR 3	AOR 3			
	21 – 25	AOR 4	AOR 4			
	26 – 30	AOR 5	AOR 5			
	31 – 35	AOR 6	AOR 6			
	36 – 40	AOR 7	AOR 7			
	1 – 4	-	HV-P1	2	Float 32	HART Variables transmitted on positions P1 - P8
	5 – 8		HV-P2			
	9 – 12		HV-P3			
	13 – 16		HV-P4			
	17 – 20		HV-P5			
	21 – 24		HV-P6			
25 – 28	HV-P7					
29 – 32	HV-P8					
Output	1 – 5	AO 0	AO 0	1	Float 32 + Status DSARIO1	Analog output signals AO 0 – AO 7 Analog format with status according PI specification
	6 – 10	AO 1	AO 1			
	11 – 15	AO 2	AO 2			
	16 – 20	AO 3	AO 3			
	21 – 25	AO 4	AO 4			
	26 – 30	AO 5	AO 5			
	31 – 35	AO 6	AO 6			
	36 – 40	AO 7	AO 7			

PROFINET interface description

3.2.2 DIM, DIM+CF (9470/.. 9471/.. 9472/..)

On the modules 9470, 9471 and 9472 the inputs 14 und 15 can optionally be used as digital- (DI), counter- (C) or frequency input (F).

Through selection of different submodule descriptions the cyclically transmitted data area can be chosen.

Module	Operation mode		Input Data	Output Data	Sub-module	Signal types
9470 / .. -16-1. 9471 / .. -16-1.	DIM 16	DIM 16 + 2CF	16 DI + Status	-	1	DI with status
	-		C14+15	Counter register C14, C15	2	Counter
	-		F14+15	-		Frequency
9470/3x-16-xx 9471/35-16-xx 9472/35-16-xx	DI/DO 16	DI/DO 16+8CF	16 DI + Status	16 DO + Status	1	DI or DO with status
	-		C/F 8 - 15	Counter register C8 - C15	2	Counter
	-		F8 - 15	-		Frequency

Signal definition with Parameter 'Invert all inputs of the module = No':

9470/ ...	9471/ ...	
I < 0,05 mA	-	open circuit alarm
I < 1,2 mA	U < 5 V	Signal = 0
I > 2,1 mA	U > 13 V	Signal = 1
R _L < 100 Ohm	-	short circuit alarm

Even if DIM 16+CF (with counter / frequency) is selected the inputs 14 und 15 are mapped to the standard DI data area (byte 2) and therefore can be used as standard DI inputs.

Data type DSDRIO1:

Status						Value		
Bit7	Bit6	Bit5	Bit4	Bit3	Bit2	Bit1	Bit0	Function
Status value according PI see Analog format with status according PI specification						0	0	Signal = 0
						1	1	Signal = 1

Signals and states are generated and transmitted synchronized and consistent

PROFINET interface description

Data

Data	Byte	all DIM (947x/3x in compatible mode)		DIOM 9470/3x, 9471/35, 9472/35 (IS1+)		Sub-module	Type	Application			
		DIM	DIM +2CF	DI/DO	DI/DO +8CF						
Input	1	DI 0 + Status				1	UINT8 RIO Data Type 6	DI Signals with Status			
	2	DI 1 + Status									
									
	16	DI 15 + Status									
	1-3		C 14		C 8	2	UINT16 +Status DSARIO2	Counter 16 Bit	Not updated (= 0) if Opera- tion mode = 32 Bit		
	4-6		C 15		C 9			Up/Down Counter 16 Bit			
	7-9		↑		C 10						
			
	23+24				C 15						
	25-29				C 8, 9			UINT32 +Status DSARIO4		Up/Down Counter 32 Bit	Not updated (= 0) if Opera- tion mode = 16 Bit
	30-34				C 10, 11						
	35-39	-		-	C 12, 13						
	40-44				C 14, 15						
	45-49 (7-11)		F 14		F 8			Float 32 +Status DSARIO1		Counter and Frequency measurement with scaling.	counter scaling: 16 Bit: 0% = 0, 100% = 2 ¹⁶ -1 32 Bit: 0% = 0, 100% = 2 ³² -1 *1)
	50-54 (12-16)		F 15		F 9						
						
	75-79				F 14						
	80-84				F 15						
Output	1			DO 0 + Status		1	UINT8 RIO Data Type 6	DO Signals with Status			
	2			DO 1 + Status							
							
	16			DO 15 + Status							
	1		C14,15 Start, Stop Reset		Reset C8-15	2	BitStr. 8	Counter control register			
	2		Reserved		Start/Stop C8-15						

*1) Using an input pair in operation mode Up/Down counter or frequency with direction, then the first Float 32 variable of the pair represents the scaled value. The second Float variable of the pair is delivering the error code 'Not a number'. The scaling parameters of the second Float variable have not function in this case.

Counter control register DIM+2CF:

Byte	Bit	Function	Allocation
1	0	Reset Counter C14	0 = Run, 1 = Reset (Counter = 0)
	1	Reset Counter C15	
	2	Start/Stop C14	0 = Counter Run, 1 = Counter Stop
	3	Start/Stop C15	
	4 - 7	Reserved	-
2	0 - 7	Reserved	-

Counter control register DIOM+8 CF

Byte	Bit	Function
1	0	Reset Counter C8

	7	Reset Counter C15
2	0	Start/Stop C8

	7	Start/Stop C15

PROFINET interface description

Operation mode 'counter'

Count mode:	Incremental / decremental with overflow / underflow
Count event:	Positive / Negative edge selectable.
Signal in case of error:	freeze last value (Initial value 0)
Alarming:	Status and channel diagnosis
Reset:	Reset counter register to '0'
Start/Stop:	in 'Stop' mode input pulses are ignored (not counted)

all DIM with counter (9470/3x in comp. mode)	DIOM 9470/3x (IS1+)	count range	count event
	Counter 16 Bit	UINT16 0 – 65535	Increment on edge
-	Up/Down Counter 16 Bit		Increment / Decrement depending on rotation direction
-	Up/Down Counter 32 Bit	UINT32 0 – 4.294.967.295	

Counting and rotation direction detection:

For counting and frequency measurement with direction detection two DI Inputs are used as a functional pair. The phase shift of the two signals is measured.

The mechanical positioning of the two sensors must be chosen to ensure the overlapping of associated pulses.

Operation mode	Application
Up/Down Counter	Up- or down counting of incoming pulses depending on direction
Frequency with direction	Rotation frequency and direction detection for rotating machines

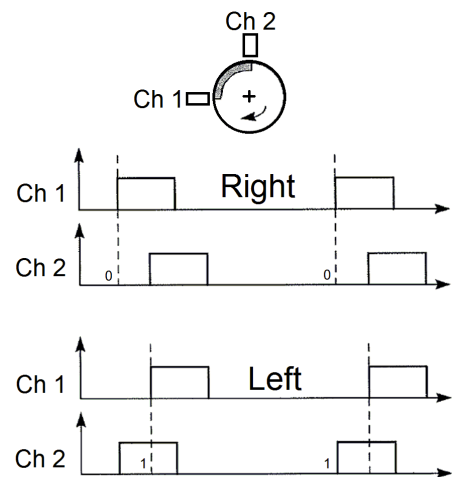

Signal allocation in cyclic Input data in operation mode Up/Down Counter or Frequency with direction:

Input data	Usage
first DI bit of a input pair	DI digital value of first input
second DI bit of a input pair	Rotation direction 0 = Right / forward (Pulse on first input comes first) 1 = Left / backward (Pulse on second input comes first)

PROFINET interface description

Signal and status in operation mode 'counter':

Counters are set to 0 during IO module startup.

The status bit is initialized with 0x24 = signal disturbed (bad).

With the Reset bit in the control register the counter register is set to '0' and the status bit is set to 0x80 = signal OK.

In case of errors (short circuit, open circuit, bus failure ...) the status bit is set to bad and will be held at bad until the next Reset. Therefore disturbances during the count procedure are recognizable via the status bit.

In case of lost Data Exchange with the AS and recover within the parameterized output hold time or in case of CPU redundancy switch over the count procedure will not be disturbed.

Using an input pair in operation mode Up/Down counter or frequency with direction the status bits of both channels are set to bad in case of a signal error of one of the two channels.

For **summation of 16 Bit counters** in the AS the count difference of two consecutive read cycles must be added from the AS. Counter overflow / underflow must be detected and considered. Maximum one overflow / underflow within one AS cycle shall occur.

32 Bit counter with direction input

For counting without direction detection only the first input of a 32 Bit Up/Down Counter channel pair shall be used. The direction bit must not be used by PLC in this case. Error detection of the second not used input channel shall be set to 'Off'. Pulses on the first input will increment the counter if the second input is open.

Pulses on the first input will decrement the counter if the second input is shorted.

Operation mode 'Frequency'

Module	Max. number signals per module	Operation mode	Measurement method	Scaling [Hz / Bit]	Resolution [Hz]
all DIM with Frequency-measurement (9470/3x in comp. Mode)	2	Frequency 1 Hz - 1 kHz	Pulse time measurement	0,05	+/- 0,05
		Frequency 20 Hz - 20 kHz	Gate time 50 ms	1	+/- 20
		Frequency 5 Hz - 20 kHz	Gate time 200 ms	1	+/- 5
		Frequency 1 Hz - 20 kHz	Gate time 1 s	1	+/- 1
DIOM 9470/3x, 9471/35, 9472/35 (IS1+)	8	Frequency 0,1 - 600 Hz	Pulse time measurement	0,01	+/- 0,01
		Frequency 1 Hz - 3 kHz		0,05	+/- 0,05
		Frequency 1 Hz - 20 kHz		0,5	+/- 0,5
	4 pairs	Frequency 1 Hz - 20 kHz with direction		0,5	+/- 0,5

PROFINET interface description

Signal scaling:

all DIM with Frequency measurement (9470/3x in compatible mode):					
Measuring range		Units		% *1)	Range
1 Hz – 1 kHz	x – 20 kHz	decimal	hex		
1,3 kHz	-	26000	6590	130 %	Over range
1,1 kHz	22 kHz	22000	55F0	110 %	
1 kHz	20 kHz	20000	4E20	100 %	Nominal range
500 Hz	10 kHz	10000	2710	50 %	
0 Hz	0 kHz	0	0	0 %	

DIOM 9470/3x, 9471/35, 9472/35 (IS1+)						
Measuring range			Units		% *1)	Range
0,1 Hz – 600 Hz	1 Hz – 3 kHz	1 Hz - 20 kHz	Dec.	Hex		
> 655,34 Hz	> 3,276 kHz	-	65535	0xFFFF		Overflow
655,34 Hz	3,276 kHz	-	65534	0xFFFE	164 %	Over range
600 Hz	3 kHz	-	60000	0xEA60	150 %	Nominal range
440 Hz	2,2 kHz	22 kHz	44000	0xABE0	110 %	
400 Hz	2 kHz	20 kHz	40000	0x9C40	100 %	
200 Hz	1 kHz	10 kHz	20000	0x4E20	50 %	Nominal range
0 Hz	0 kHz	0 kHz	0	0x0000	0 %	

*1) Scaling of frequency measurements in IS1 DTM and I.S.Wizard

all DIM with Frequency (9470/3x in comp. mode)	Phys. 0 – 100% correlate digital 0 – 20000
DIOM 9470/3x (IS1+)	Phys. 0 – 100% correlate digital 0 – 40000

Scaling on PROFINET see [Scaling for AI and AO signals](#)

Signal in case of error: freeze (Initial value 0)
Diagnosis: status und channel diagnosis

Behavior in case of too high input frequencies:

If the input frequency is higher than the maximum of the selected measurement range, input pulses can be lost. In this case the measured value is smaller as the existing frequency at the input. No alarm is generated.

Signal Filter:

The measured frequency signal can be filtered by the DIOM 9470/3x to reduce jitter. Additionally a pulse extension function is executed for the DI signals.

Parameter	Selection	Pulse extension for DI signals	Filter / smoothing for frequency measurement
Pulse extension / Frequency Filter	0 s / off	0 s	off
	0,6 s / small	0,6 s	small
	1,2 s / medium	1,2 s	medium
	2,4 s / large	2,4 s	large

PROFINET interface description

Pulse extension:

This function can be used to increase the length of short pulses. With this e.g. a short activity of a manual sensor (term approx. 10 .. 50 ms) can be extended to a time selectable by parameterization (T = 0,6 sec., 1,2 sec., 2,4 sec.).

Short pulses can be recognized surely from the AS also with slower cycle times of the application software

Pulse extension with not inverted operation:

(Parameter 'Invert all inputs of the module' = No)

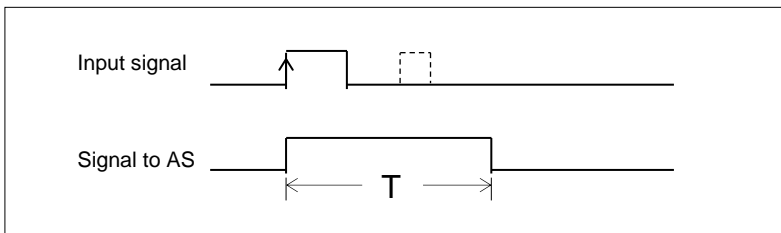

T = 0,6 sec., 1,2 sec., 2,4 sec.

Pulses which are longer than the parameterized time T, are not extended.
Short pulses during time T are suppressed.

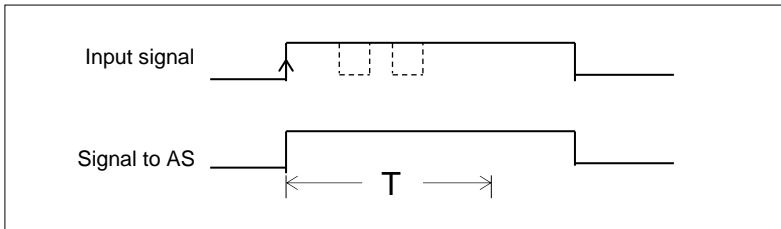

Pulse extension with inverted operation:

(Parameter 'Invert all inputs of the module' = Yes)

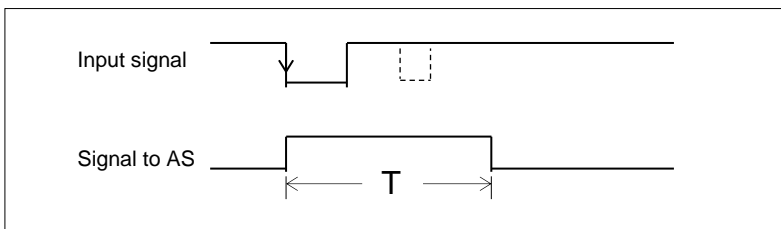

Signal LEDs:

DIOM with signal LEDs display the extended 'Signal to AS'.

PROFINET interface description

3.2.3 DOM (9475/..., 9477/..., 9478/..)

Signal allocation

Daten	Byte	DOM 8	DOM 6	DOM 4	Sub-module	Type
			9477/12-06-12			
Input	1	Status_S0	Status_S0	Status_S0	1	UINT8 RIO Data Type 6
	2	Status_S1	Status_S1	Status_S1		
	3	Status_S2	Status_S2	Status_S2		
	4	Status_S3	Status_S3	Status_S3		
	5	Status_S4	Status_S4	-		DSDRIO1 Status with readback
	6	Status_S5	Status_S5	-		
	7	Status_S6	-	-		
	8	Status_S7	-	-		
Output	1	DO 0	DO 0	DO 0	1	UINT8 RIO Data Type 6
	2	DO 1	DO 1	DO 1		
	3	DO 2	DO 2	DO 2		
	4	DO 3	DO 3	DO 3		
	5	DO 4	DO 4	-		DSDRIO1
	6	DO 5	DO 5	-		
	7	DO 6	-	-		
	8	DO 7	-	-		

Readback: The written output value can be read via Bit 0 of the associated status byte.

Datatype DSDRIO1: (data type numerical identifier 0x105)

Status						Value					
Bit7	Bit6	Bit5	Bit4	Bit3	Bit2	Bit1	Bit0		DOM	DOMR	DOMV
Status value acc. PI see Analog format with status according PI specification						x	0	False	output high impedance (actuator = Off)	relay contact = open	Valve closed
						x	1	True	output is powered acc. type specification (actuator = On)	relay contact = closed	Valve open

X: Bit = 0 (reserved)

PROFINET interface description

3.3 HART variables

In addition to the analogue process value, HART field devices offer the option of digitally reading up to four process variables (HART variables HV) from the transmitter.

IS1+ offers the option of mapping such HART variables to the cyclic input data area of PROFINET.

Optionally eight HART variables of an IS1+ HART module (AIMH, AUMH, AOMH) can be transmitted in addition to the cyclic data.

This can be selected optionally when configuring a field station.

3.3.1 Data format

HART variables are transmitted as IEEE floating-point numbers (4 bytes).

If a HART variable cannot be read (e.g. HART device undergoing startup, not connected, defective or HART variable not found, ...), value 7F A0 00 00 (Not a Number) is transmitted. This may be evaluated in the AS for generation of a signal status of the HART variables. Detailed status and diagnostic information on the HART field devices can be evaluated via HART Management Systems.

3.3.2 Selection of HART Variables

Up to 8 HART field devices can be connected to one HART module of IS1+. Since each HART field device may have up to 4 variables, this means that a maximum of 32 HART variables are possible per module.

The assignment of 4 or 8 out of these 32 variables to the positions P1 to P8 in the cyclic transmission area can be selected by parameter assignment:

Parameter name	Value range	Function
Input No. HART device for pos. 1	0 ... 7, Not used	Selection of the channel No. (input / output No.) of the HART module to which the HART field device is connected which is to be transmitted at pos. 1. If 'Not Used' is selected, value 'Not a Number' (7F A0 00 00) is transmitted.
Input No. HART device for pos. 2		Selection for pos. 2
.....	
Input No. HART device for pos. 4 (8)		Selection for pos. 4 (8)
HART variable for pos. 1	1, 2, 3, 4	Selection of the variables of the HART field device which is to be transmitted at pos. 1.
HART variable for pos. 2		Selection for pos. 2
.....	
HART variable for pos. 4 (8)		Selection for pos. 4 (8)

PROFINET interface description

3.4 HART Maintenance via IS1 DTM

Maintenance access to HART devices using FDT technology and IS1 DTMs is supported.

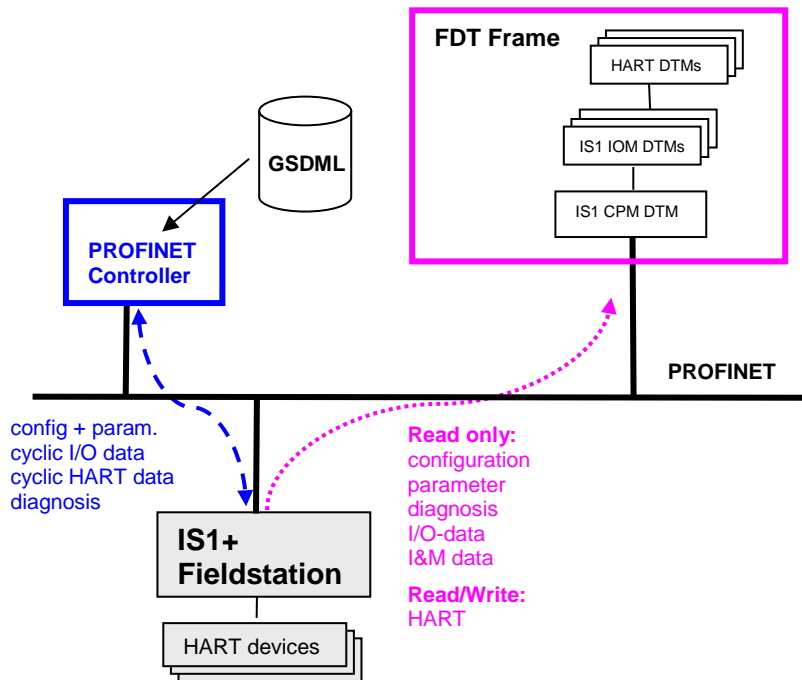

Configuration and parameterisation of the IS1 fieldstation shall be done with the PROFINET controller using GSDML.











Stand alone configuration of an IS1+ fieldstation with download from the IS1 DTM without a PROFINET controller is supported by 9442 CPU only.

All I/O modules of an IS1+ fieldstation shall be configured identically in PROFINET controller and in the FDT project. After setting into operation of the cyclic PROFINET communication from the controller the I/O module parameters can be uploaded to the IS1 DTMs and be displayed together with the diagnosis data.

PROFINET interface description

3.5 Alarm- and diagnosis data

Module Alarms

Error Type	Error Text	Help Text / Measure / Remedy	Status (NE107)	
301	IS1 configuration error from IO Controller!	Plug configured module type or change configuration of controller	Fail	
305	Slot address fail CPU	The CPU has detected an incorrect change of the slot address during operation. -> exchange CPU and send it back to STAHL service.		
306	Parameter 'Red. CPU' error.	Parameter 'Red. CPU = Yes' shall be enabled if red. CPU are plugged.	Maint	
307	Failure CPU-L	Check PM supply voltage. CPU left exchange required if OK.	Fail	
308	Failure CPU-R	Check PM supply voltage. CPU right exchange required if OK.		
309	Temperature Alarm CPU / PM	Ambient temperature around the CPU or PM is out of spec. In case of overtemperature reduce ambient temperature or increase ventilation, shadowing	OoS	
310	Maintenace Request CPU-L	Exchange of CPU left recommended due to operating conditions.	Maint	
311	Maintenace Request CPU-R	Exchange of CPU right recommended due to operating conditions.		
312	Maintenace Request PM-L	Exchange of PM left recommended due to operating conditions.		
313	Maintenace Request PM-R	Exchange of PM right recommended due to operating conditions.		
314	PM overload	Reduce PM load!	OoS	
315	Failure PM-L	Check PM left supply voltage. PM left exchange required if OK.	Fail	
316	Failure PM-R	Check PM right supply voltage. PM right exchange required if OK.		
317	Parameter 'Red. PM' error.	Parameter 'Red. PM = Yes' shall be enabled if red. PM are plugged.	Maint	
318	Slot address error PM-L	The PM left has detected an incorrect change of the slot address during operation. -> Exchange PM and send it back to STAHL.		
319	Slot address error PM-R	The PM right has detected an incorrect change of the slot address during operation. -> Exchange PM and send it back to STAHL.		
320	Socket backup memory disturbed.	System operation till next Power On/CPU Reset is possible. Socket exchange is required on next operation stop.		
402	Wrong module!	Plug configured module type or change configuration of controller	Fail	
403	No module!	Plug correct module type or exchange module.		
404	Primary rail disturbed!	Check IOM, Rail communication and CPU	Maint	
405	Redundant rail disturbed!	Check IOM, Rail communication and CPU		
406	Hardware error	Exchange module	Fail	
407	Hardware disable outputs	Outputs are switched off by hardware disable input. Output data from AS is rejected. Check and clear reason for hardware disable.		
409	Over temperature	Ambient temperature around the IOM is too high. Reduce ambient temperature or increase ventilation, shadowing	OoS	
410	Slot address error IOM	The module has detected an incorrect change of the slot address during operation. -> exchange IOM and send it back to STAHL service.	Maint	
411	Maintenance request	Exchange of module recommended due to operating conditions.		
412	Cold junction error	Check Cold Junction error measurement on module or change module	OoS	
413	2 wire calibration failed	Repeat 2 wire calibration	Fail	
414	Maximum total output current of module exceeded. Channel 3 is switched off.	Reduce total loop current.	OoS	
415	Wrong external wiring.	Check external signal wiring or signal type configuration.	Fail	
416	Wrong external supply (18..32V) or wrong extern wiring.	Check external supply (18..32V) or external signal wiring or signal type configuration.		
417	Hardware disable outputs	Outputs are switched off by hardware disable input. Output data from AS is rejected. Check and clear reason for hardware disable.		

PROFINET interface description

Channel-Diagnoses

Message / Function	Measure / Remedy	Status (NE107)	
Short circuit	<ul style="list-style-type: none"> • Check connection between IO module and sensor/actuator and remove short. • Check sensor / actuator and replace if required 	Fail	
Open circuit	<ul style="list-style-type: none"> • Check and reestablish connection between IO module and sensor/actuator. • Check sensor / actuator and replace if required 	Fail	

Signal status see [Analog format with status according PI specification](#)

3.6 I&M Identification & Maintenance Functions

I&M0 to I&M3 functions are supported by the 9442 CPU.

I&M0 (read only) contains general data about the device (DEVICE_MAN_ID, ORDER_ID, SERIAL_NUMBER, HARDWARE_REVISION, SOFTWARE_REVISION, ...).

User-specific data can be stored with I&M1 to I&M3 in the device. Default: filled with '0x20' (blank)

I&M 1	TAG_FUNCTION	32 Octets Visible String	For each device or module within a plant a unique label is necessary for the identification of its function or task. This may be a standard symbolic tag ("AKZ") out of a list or any other type of label defined by a configuration tool.
	TAG_LOCATION	22 Octets Visible String	For each device or module within a plant a unique label is necessary for the identification of its location. This may be a standard location tag ("OKZ") out of a list or any other type of label defined by a configuration tool.
I&M 2	INSTALLATION_DATE	16 Octets Visible String	The parameter INSTALLATION_DATE indicates the date of installation or commissioning of a device or module. YYYY-MM-DD hh:mm z. B. 1995-02-04 16:23
	RESERVED	38 Octets	
I&M 3	DESCRIPTOR	54 Octets Visible String	This comment field DESCRIPTOR allows customers to store any individual additional information and annotation. One source can be the tag list.

PROFINET interface description

3.7 Webserver in IS1+ CPU

A webserver is integrated in the IS1 CPUs which offers additional diagnostic functions for commissioning, maintenance and OEM service support. For access standard WEB browsers can be used.

Example: 9441 PROFINET

The screenshot shows a web browser window titled "IS1 Ethernet CPU - Windows Internet Explorer" with the address bar showing "http://172.24.47.20/". The page content includes a "Web Diagnosis" header and a "PROFINET-IO" section. On the left, there is a "Contents" menu with options like Information, BusRail, Network, Firmware, Protocol, Company, and Service Access. The main content area displays the following configuration details:

- Station Name: pn-io
- Device Handle: 5
- Host IP: 172.24.47.24
- AR Type: -
- Device Name: IS1-PN2
- Device IP: 172.24.47.20
- Subnet Mask: 255.255.248.0
- Address Conflict: No address conflict
- Address Conflict Detection Count: 0
- Timeout: 20

Below the configuration, there are two tables:

CPU Modules				
No.	Slot	Module Type	Module Status	Module Alarm
1	0-0	9441/12-00-00 CPM Z1	DATA EXCHANGE	
2	0-1	-	-	-

IO Modules					
No.	Slot	Module Type	Module Status	Module Alarm	Channel Status
1	1-1	9461/12-08-11 AIM8H			0000000111111111
2	2-1	9466/12-08-11 AOM8H		MODULE OK	0000000111111111
3	3-1	9470/22-16-11 DIM16C			1111111111111111
4	4-1	9475/12-08-51 DOM8			0000000111111111
5	5-1	9468/3x-08-xx AUM8H			0000000000000000
6	6-1	9470/3x-16-xx DIOM16C			1111111111111111
7	7-1	9475/3x-08-xx DOM8			0000000111111111
8	8-1	-	-	-	-

Example: 9442 PROFINET

The screenshot shows a web browser window titled "IS1+ Web Diagnostic - 9442 UI-E" with the address bar showing "172.24.47.74". The page features a "STAHL" logo and a navigation menu on the left with options: Overview, Module Diag, CPU + PM, Event History, Company, User Access (highlighted), User Log In/Out, Fieldstation, Network, CPU SWupdate, and Service Access. The main content area is titled "User Access" and includes the following elements:

- Navigation tabs: User Log In/Out, Fieldstation, Network, CPU Software Update
- Form fields: Name (input), User Password (masked with dots), New Password (input)
- Buttons: "User Logout" (with a wrench icon) and "Change User Password" (with a wrench icon)
- Warning message: "User logged in! Caution! Access for authorized personal only !" in red text.
- Link: "Store encrypted Passwords" in blue text.

PROFINET interface description

Password and Access concept 9442 Web Server:

The various menu items of the IS1 + Web server are divided into three groups

Group	Page	Function
IS1+ Web Diagnostic	Diagnostic Overview Plugged Modules Configured Modules Backplanes HART Live List Module Diagnostic System Diagnostic AS- Protocol CPU Parameter License Event History Company	Standard Diagnosis Information – Read Only
User Access	User LogIn/Out Fieldstation Network CPU Software Update	Network Settings and Software Update CPU Without User Passwort: Read Only With User Passwort: Read- und Write of important User Data like IP-Address, Device Name,
Service Access	Service LogIn/Out	Service Information

User LogIn/Out

The user password by default is set to: **R.STAHL**

The user shall to change it after a successful user login.

In case of forgotten password the function 'store encrypted passwords' can be used to save a file from which the R.STAHL Service can read the used password. So that a login is possible and the used password is to change again by the user afterwards.

3.8 LED and LCD displays of the 9441 CPU

The operational state and the communication on the PROFINET can be assessed on site using the LEDs and the LCD display on the 9441 CPU of an IS1 field station.

Additionally the signal values, the signal and module alarms can be displayed on the LCD display.

For details, see the IS1 9441 operating instructions.

3.9 Online behavior of the IS1+ field station.

Online parameter and configuration changes are not supported by actual PN IO-Controllers for PN IO-devices with GSDML parameterization.

However a PNO draft specification is available describing such future functionality.

- **PROFINET IO Configure in Run Doc. No. 2.512**

PROFINET interface description

3.10 Transmission time:

Total delay of input signals (worst case):

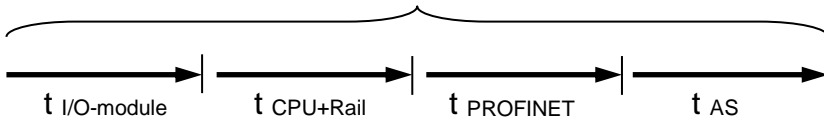

Total delay of output signals (worst case):

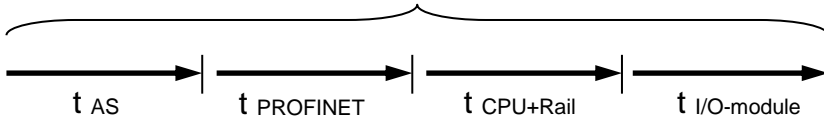

$t_{I/O\text{-module}}$ max. Signal delay see operation manual of the different IS1+ I/O modules.

$t_{CPU+Rail}$ ca. 4ms + number IO module * 1 ms

$t_{PROFINET}$

Device Interval				
Minimum (default)	Optional *1)			
8 ms (9441)	8 ms	16 ms	32 ms	...
4 ms (9442)				

*1) depending settings of PROFINET controller

t_{AS} AS cycle + further delays in automation system (AS)

PROFINET interface description

4 List of abbreviations:

AS	A utomation S ystem
AIM	A nalogue I nput M odule
AIMH	A nalogue I nput M odule + H ART
AUMH	A nalog U niversal M odule AI/AO with H ART
SAIMH	S afety A nalogue I nput M odule + H ART (PROFIsafe)
AOM	A nalogue O utput M odule
AOMH	A nalogue O utput M odule + H ART
DIM	D igital I nput M odule
DIOM	D igital I nput O utput M odule
DOM	D igital O utput M odule
DOMR	D igital O utput M odule R elays
DOMV	D igital O utput M odule V alves
GSDML	G eneral S tation D escription M arkup L anguage
HW	Hardware
IOM	General description of I/O M odule
IOC	I nput O utput C ontroller -> P ROFINET C ontroller (logical view)
IOD	P ROFINET D evice (z.B. IS1+ CPU 9442)
MRP	M edia redundancy protocol
NAP	N etwork A ccess P oint (z.B. IS1+ CPU 9442)
PM	P ower M odule (power pack)
SW	Software
SIL	S afety I ntegrity L evel
SNMP	S imple N etwork M anagement P rotocol
TIM	T emperature I nput M odule

PROFINET interface description

5 Release notes:

Version Interface description PROFINET	Extensions / Changes
V 2.00	First official release
V 2.02	Signal Type of MIN_VALUE and MAX_VALUE changed to Float
V 2.03	HART communication via IS1 DTM added
V 2.04	new IS1+ IO module 9482 TIM added
V 3.01	New IS1+ CPU 9442 added new IS1 modules added: <ul style="list-style-type: none"> - 9469/35 UMH Z2 Ex n - 9471/35 DIOM Z2 Ex n - 9472/35 DIOM-24V Z2 Ex n Parameter PM 9445 Redundant added
V 3.02	Description of Data word structure 9469 for Digital in/out extended
V 3.03	CPU Parameter 'Ignore Output Signal Status' added.
V 3.04	Info added: Shared Device and Shared Input cannot be used in combination with system redundancy S2!
V 3.05	Description Behaviour of the outputs in case of error extended.

6 Further reading

PROFINET Design Guideline	PNO Doc. 8.062
PROFINET Installation Guideline for Cabling and Assembly	PNO Doc. 8.072
PROFINET Installation Guideline for Commissioning	PNO Doc. 8.082

7 Support address

R. STAHL Schaltgeräte GmbH

Business Unit Automation Interface and Solutions

eMail: support.automation@r-stahl.com

Supportinformationen: <http://www.stahl.de>

Service Hotline IS1: +49 (7942) 943-4123

Telefax : +49 (7942) 943-40 4123